

## #81062, #81065, #81072 & #81075 T-Maxx & E-Maxx (all versions) Bulkheads

### What's Included:

**Front Bulkhead kits** include 1 - Left Front Bulkhead, 1 - Right Front Bulkhead, 8 - M3 Locknuts, 4 - M3 x 16mm Flathead Screws and 4 - M3 x 22mm Flathead Screws.

**Rear Bulkhead kits** include 1 - Left Rear Bulkhead, 1 - Right Rear Bulkhead, 8 - M3 Locknuts, 4 - M3 x 20mm Flathead Screws and 4 - M3 x 22mm Flathead Screws.

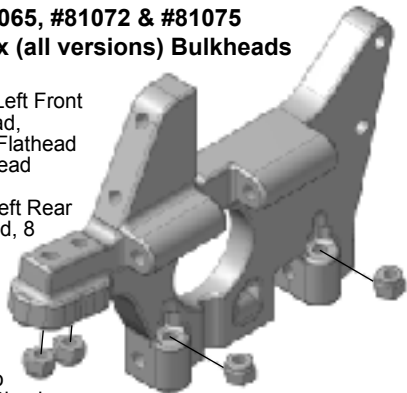

### Assembly Notes: **RPM**

bulkheads are stock replacement parts with several modifications to help improve crash survivability. Simply remove your stock bulkheads and replace them with your new **RPM** versions.

1) Discard the stock screws that attach the bulkheads to the chassis and skid plate (8 screws in total) and replace them with the included screws. Press the bulkhead-to-chassis M3 locknuts in place **before** installing the bulkheads in the vehicle. Take careful note of the orientation of the locknuts (refer to the illustration above). The flat area of the locknut should rest against the plastic. The longer M3 x 22mm screws attach the skid plates to the bulkheads. □

2) **Front Bulkheads:** Use the included M3 x 16mm flathead screws to attach the bulkheads to the chassis. Use the M3 x 22mm flathead screws to attach the skid plates to the bulkheads.

3) **Rear Bulkheads:** Use the included M3 x 20mm flathead screws to attach the bulkheads to the chassis. Use the M3 x 22mm flathead screws to attach the skid plates to the bulkheads. □

□

**Notes:** **RPM** Bulkheads are built to tight tolerance specifications and enclose the differential much tighter than the stock versions, ensuring a rigid mount for the differential housing. Because of the tight fit, install the bulkheads in this order for ease of installation - 1) Bulkheads to chassis 2) A-arms to bulkheads 3) Bulkheads to skid plate 4) Shock Tower to bulkheads 5) Front bumper / bulkhead brace to bulkheads.

**Caution:** The locknuts allow a much firmer feel when tightening screws. Because of this, use extreme caution and **DO NOT OVERTIGHTEN THE SCREWS!** Too much pressure can easily break or deform molded skid plates & chassis. Simply tighten until snug. The locknuts will keep the screws in place.