

*Venture 50*TM ARF

ASSEMBLY INSTRUCTIONS



VENTURE SPECIFICATIONS

Overall Length	47.32"	Tail Rotor Diameter	9.17"
Overall Height	16.29"	Gear Ratio	9.78:1 : 5.18
Main Rotor Diameter	52.63"	Gross Weight	7.0-7.5 lb

TABLE OF CONTENTS

Section	Description	Page	Section	Description	Page
	Introduction	3		Radio Data Sheet: X-378 Basic Setup	41
	Venture 50 3D ARF Features	4		Radio Data Sheet: X-378 3D Setup	42
	Radio System Requirements	4		Radio Data Sheet: XP8103 Basic Setup	43
	Engine Requirements	5		Radio Data Sheet: XP8103 3D Setup	44
	Building Supplies	5		Radio Data Sheet: PCM10X 3D Setup	45–46
	Required Tools	6		Final Servo Adjustment and Radio Setup	47–49
	Required Field Equipment	6		Final Preflight Check	50
	Hardware Identification	7		Blade Tracking Adjustment	50
1-1	Tail Boom Installation	8		Blade Tracking Identification	50
1-2	Drive Belt Connection and Adjustment	8		Advice and Basic Hover Training Practices	51
1-3	Tail Boom Brace Installation	9		General Maintenance	52
1-4	Tail Fin Attachment	9		Troubleshooting Guide	53
1-5	Tail Control Rod Assembly	10		Preassembled Components	54
1-6	Tail Control Rod Installation/Horizontal Fin Attachment	10	1-1	Clutch Bell Assembly	54
2-1	Engine Mount/Cooling Fan Installation	11	1-2	Tail Drive Pinion/Bearing Assembly	54
2-2	Clutch Assembly Attachment	11–12	1-3	Elevator Arm Assembly	55
2-3	Starter Shaft/Hex Adapter Installation	12	1-4	Fuel Tank Assembly	55
2-4	Engine Installation	13	2-1	Main Frame Section Assembly	56
2-5	Muffler Installation	13	2-2	Main Frame Clutch/Tail Pinion/Elevator/Fuel Tank	57
3-1	Servo Installation	14	2-3	Front Radio Bed/Cooling Shroud Installation	58
3-2	Gyro/Receiver/Switch Harness/Battery Installation	15–16	3-1	Main Drive Gear/Autorotation Assembly Installation	59
	Understanding Swashplate Control Systems	17–18	3-2	Landing Gear Assembly Installation	60
	How JR 120 CCPM Works	19	4-1	FlyBar Control Arm/Seesaw Arm Assembly	61
	Radio System Requirements	19	4-2	Main Blade Holder Attachment	61
	CCPM Software Activation and Initial Adjustment	20–23	4-3	Main Blade Holder Assembly	62
	Important CCPM Programming Guidelines	24	4-4	Washout Assembly	63
3-3	CCPM Servo Arm Preparation and Installation	25	4-5	Swashplate Assembly	63
3-4	CCPM Servo Centering with the Sub-Trim Function	26–27	4-6	Tail Pitch Plate Assembly	64
3-5	CCPM Linkage Connection	28	4-7	Swashplate/Washout Assembly Installation	64
3-6	Checking the Swashplate for Level	29	4-8	Rotor Head Installation	65
3-7	Pitch-to-Aileron Mixing Adjustment with Travel Adjust	30	4-9	Flybar Installation	65
3-8	Pitch-to-Elevator Mixing Adjustment with Travel Adjust	31	4-10	Flybar Paddle Attachment	66
3-9	Tail Control Rod Servo Connection	32	4-11	Rotor Head/Swashplate Control Rod Installation	66
3-10	Throttle Linkage Installation	33	5-1	Tail Gear Case Preparation	67
4-1	Body Assembly/Canopy Attachment	34	5-2	Tail Gear Case Assembly	67
4-2	Decal Attachment	35	5-3	Tail Center Hub Assembly	68
4-3	Main Rotor Blade Balancing	36	5-4	Tail Blade Holder Assembly	68
4-4	Main Rotor Blade Attachment	36	5-5	Tail Pitch Control Lever Installation	69
4-5	Optional 3D Control System Setup	37–38	5-6	Tail Boom Brace Assembly	69
	Radio Data Sheet: XP662 Basic Setup	39		Parts Diagrams/Parts Listings	70–83
	Radio Data Sheet: XP662 3D Setup	40			

Venture50™

INTRODUCTION

Thank you for purchasing the JR Venture™ 50 3D ARF helicopter. The Venture 50 has been designed to provide the aspiring 3D Heli pilot with a model that is very reliable and durable, while featuring outstanding 3D performance and affordability. Featuring full ball bearings at all critical locations and a high quality Swashplate, the Venture 50 will retain its precision and reliability through many flights. The Venture's unique two-piece box frame design adds rigidity to the model, while keeping the weight and parts count to a minimum. The Venture is equally suited for both the aspiring and accomplished 3D pilot, thanks to the optional 3D control system parts and instructions included with each kit. In its stock form, the Venture is very smooth and predictable, giving the aspiring 3D pilot an additional step to success.

JR CCPM

To take the Venture's design to the next level, JR's designers turned to CCPM (Cyclic/Collective Pitch Mixing). CCPM is a unique control system that mounts three servos below the swashplate with short, straight linkages directly to the swashplate at 120 degree intervals. With CCPM, complex collective and cyclic mixing is accomplished electronically, rather than mechanically. As a result, many parts are eliminated, along with excessive control system play, not to mention quicker building and lower maintenance.

What's more, you get more servo power from CCPM. That's because instead of one servo moving the collective, you now have three. Instead of one servo moving the cyclic, you have two.

Before you begin the assembly of your Venture 30 CP, we suggest that you first review the entire instruction manual to become familiar with the assembly sequences and parts layout.

Warning

The radio controlled model helicopter contained in this kit is not a toy but a sophisticated piece of equipment. This product is not recommended for use by children. Radio controlled models such as this are capable of causing both property damage and/or bodily harm to both the operator/assembler and/or spectator if not properly assembled and operated. Horizon Hobby, Inc. assumes no liability for damage that could occur from the assembly and/or use/misuse of this product.

AMA Information

We strongly encourage all prospective and current R/C aircraft pilots to join the Academy of Model Aeronautics. The AMA is a non-profit organization that provides services to model aircraft pilots. As an AMA member, you will receive a monthly magazine entitled *Model Aviation*, as well as a liability insurance plan to cover against possible accident or injury. All AMA charter aircraft clubs require individuals to hold a current AMA sporting license prior to operation of their models. For further information, contact the AMA.

Academy of Model Aeronautics
5151 East Memorial Drive
Muncie, IN 47302
(317) 287-1256

Preassembly Information

All small hardware (nuts, bolts, washers, etc.) for each step are separated and packaged separately within the main parts bags. It is suggested that you place all of the hardware in an open container (e.g., coffee can) during assembly so as not to lose any of the small parts. It may also be helpful to familiarize yourself with the various sizes of screws, bolts, nuts, etc., as illustrated in the appropriate assembly section before you begin assembly. In most cases, at the end of each assembly section, there should be no parts remaining.

Great care has been taken in filling the bags with the correct quantity of parts and hardware for each section. However, occasionally mistakes do happen. In the event that you find a parts shortage or are in need of technical assistance, please contact your local JR heli division parts dealer or the Horizon Service Center directly.

Horizon Service Center
4105 Fieldstone Road
Champaign, IL 61822

Venture Helplines
(217) 355-9511 (9a.m. to 5p.m. CST)
E-mail: venturehelp@horizonhobby.com

VENTURE™ 50 3D ARF FEATURES

CCPM (Cyclic/Collective Pitch Mixing):

More Accurate: Control system play is totally eliminated thanks to full ball bearings and a high-grade swashplate

Simpler: Fewer links to set up and maintain

More Powerful: Collective has three times the servo power, cyclic has double

Special 3D Rotor Head Design

The Venture 50's updated 3D rotor head features an aluminum center hub, heavy duty spindle shaft, 3D dampener set, and main blade holder thrust bearings to handle the rigors of 3D flight like never before

High Quality Aluminum/Composite Swashplate

Improves control accuracy, eliminates the need for expensive Swashplate upgrades

Two-Piece Box Frame System

Provides excellent rigidity and vibration absorption

One-Way Hex Start Shaft System

Provides positive starting, starter shaft utilizes a one-way bearing that allows the shaft to stop after the engine is started

Belt-Driven Tail Rotor Design with LSD Slipper Clutch

Provides easy adjustment and low maintenance, eliminates the need for optional/expensive tube drive shafts. The added LSD clutch allows the Ventures tail to be partially driven for aerobatic autorotations

Precision Ball Bearings at All Critical Locations

Provide low wear, high precision and reduced maintenance

Ultra-Low Parts Count

Adds reliability and ease of maintenance

Self-Aligning One-Piece Heavy Duty Steel Clutch System

Offers easy installation and adjustment with exceptional reliability

Rearward-Facing Engine Design

Provides easy access to the glow plug for starting, engine slips easily through the main frame for trouble free engine maintenance

Dual Boom Braces

Offers increased rigidity of the tail assembly for increased gyro holding power. Also eases glow plug access and replacement

Included Header Tank System

An industry First! Improves engine performance and consistency throughout the entire flight. Increases flight times, and provided a fuel level visual during flight

Superior Parts Fit and Finish

Make assembly trouble-free and enjoyable

Optional 3D Control System Setup Included

Converts the Venture(tm) from a smooth and predictable 3D trainer to an all out extreme 3D machine with the use of the included aggressive 3D paddles and Swashplate ball spacers for ultra aggressive 3D flight

ADDITIONAL ITEMS REQUIRED TO COMPLETE THE VENTURE 30CP

1. RADIO SYSTEM REQUIREMENTS (NOT INCLUDED):

6-channel or greater R/C helicopter system with 120° CCPM function (see list below), 5 servos, 1000mAh receiver battery, and gyro

CCPM-Ready JR Radio Systems

Most current JR Heli radio systems (XP662, XP8103 w/digital trims, 10X, as well as older 10 series systems) are equipped with 120° CCPM electronics for use with the JR CCPM machines. Radios you may be flying now, like the X347, X388S, XP783, and XP8103* have CCPM capability built in, but require activation by the Horizon Service Department. Please call (217) 355-9511 for details.

*Please note that many XP8103 systems have the CCPM function already activated. Please check with the Horizon Service Center for details.

CURRENT RADIO SYSTEMS

JRP1656** PCM 10X, 5-8231 Servos (50/53/72 MHz)
 JRP165TX PCM 10X, Transmitter Only (50/53/72 MHz)
 JRP8622** XP8103FM, 5-517 Servos (50/53/72 MHz)
 JRP8653** XP8103PCM, 5-531 Servos (50/53/72 MHz)
 JRP7425** X-378 FM 5-537 Servos (72MHz)
 JRP6822** XP662 FM, 5-537 Servos (72MHz)



JR XP662

JR X-378

JR 10X

JR XP8103 DT



JR AirPac™



G500T Gyro



3" Servo Extensions (2)

2. ENGINE REQUIREMENTS (NOT INCLUDED):

A .46-.52 R/C helicopter engine

A special helicopter-type muffler is also required.



Webra Speed .52 AAR HELI (WEBE520)



Revolution .50 Heli Muffler (RV01150)

3. BUILDING SUPPLIES (NOT INCLUDED):

The following items are needed to complete the assembly of the JR Venture™:



Fuel Filter



Glow Plugs



Nylon Wire Ties (secure radio wires)



2' Silicone Fuel Tubing



Threadlock
(blue required)



Double-Sided Servo Mounting Tape



NOH600RP Razor Pro Symmetrical, 600mm

4. REQUIRED TOOLS (NOT INCLUDED):



Phillips Screwdriver



Nut Drivers: 4, 5, 7 mm



Needle-Nose Pliers



Scissors
(DYN2511)



Drill and Drill Bits



Crankshaft Locking Tool
(RV01007)



X-ACTO Knife



Metric Ruler



Ball Link Pliers



Allen Wrenches:
1.5, 2.0, 2.5, 3.0 mm



Universal Blade Balancer
(KSJ528)



JR Ball Link Sizing Tool
(JRP960219)
(optional)

5. REQUIRED FIELD EQUIPMENT (NOT INCLUDED):



12-Volt Electric Starter
(HAN110)



Long Reach 1.5-Volt Glow Plug
Battery (DYN1960)

or



Long Reach Remote Glow Plug
Adaptor (HAN121)



12-Volt Starting Battery
(HAN102)



Helicopter Fuel, 15%–30%



Fuel Pump (KSJ860)



Pitch Gauge
(JRP960326)



Hex Starting Shaft (JRP960090)

HARDWARE IDENTIFICATION

There are many various sizes and shapes of hardware included in this kit. Prior to assembly, please be careful to identify each screw by matching it to the full size screw outlines included in each step.

All of the hardware, screws, nuts, etc., contained in the Venture™ kit are described in the following A, B, C manner:

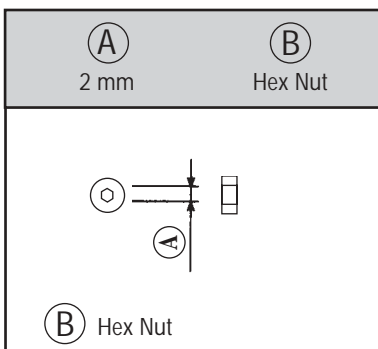
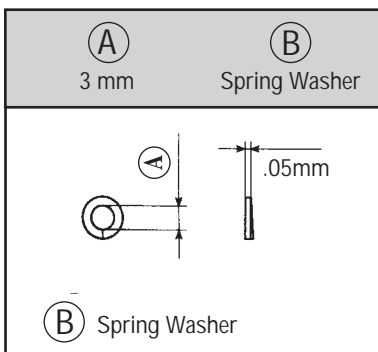
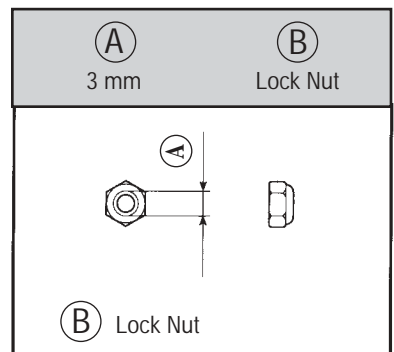
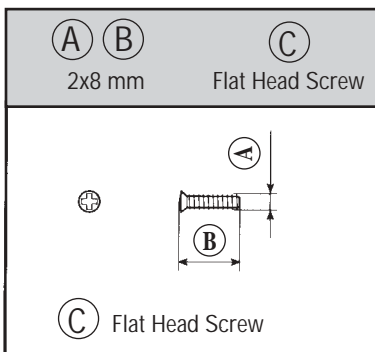
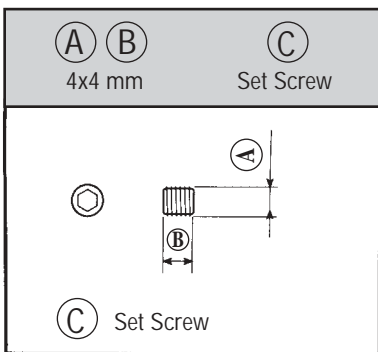
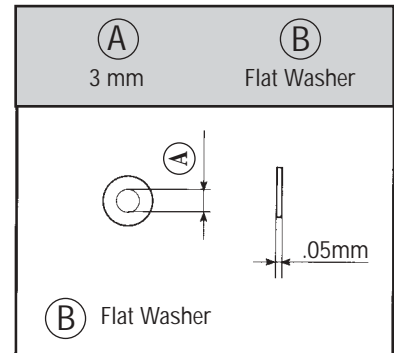
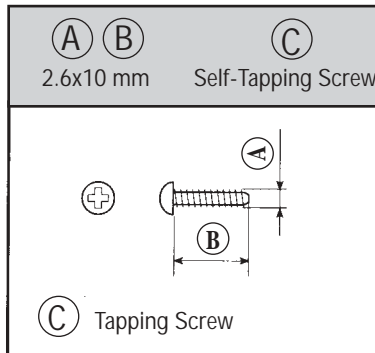
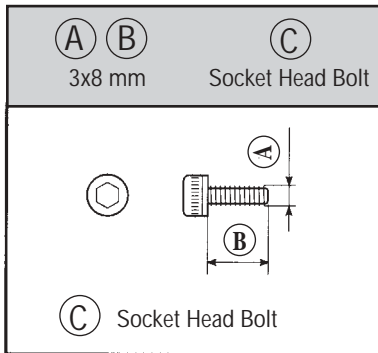

1-1

TAIL BOOM INSTALLATION

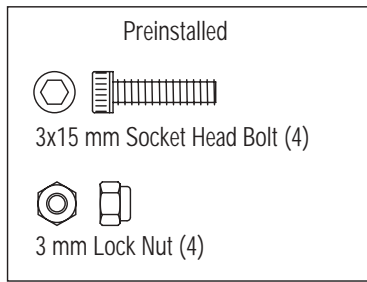

Insert the tail boom assembly into the rear of the frame as shown.

Note: Check to make sure that the belt is not twisted inside the boom prior to insertion.

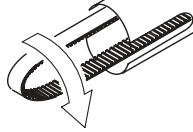

Twist the tail drive belt 90°.

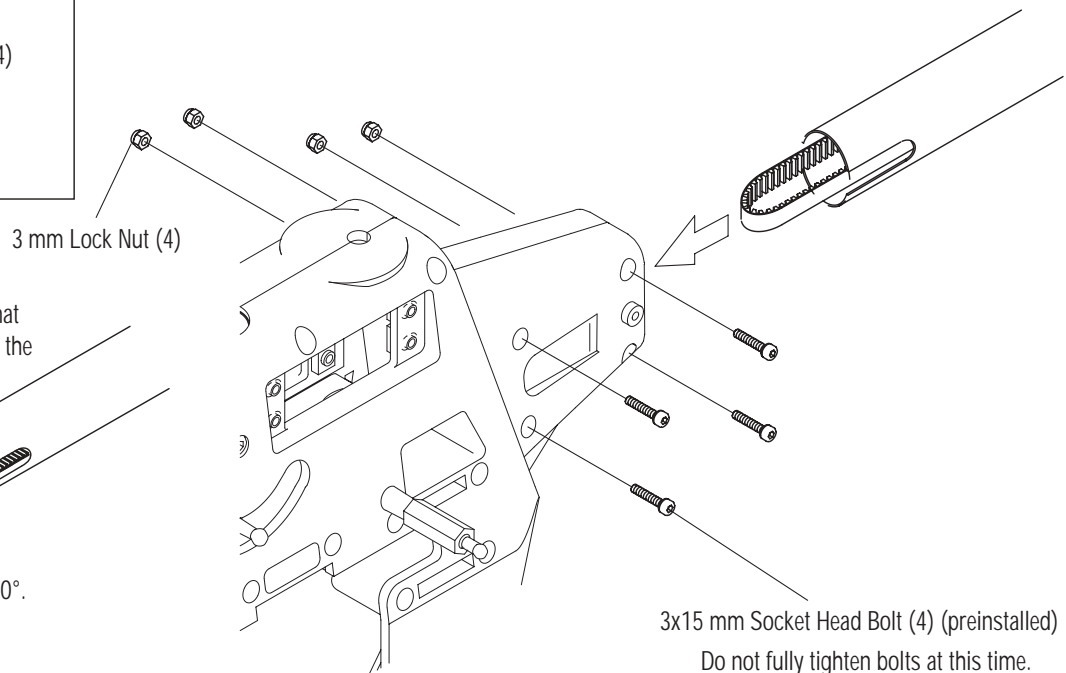

1-2

TAIL DRIVE BELT CONNECTION AND ADJUSTMENT

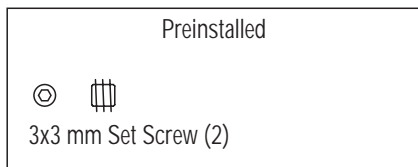

Engage the tail drive belt over the front pulley. Be certain to note the correct rotation (shown below). Set the belt tension per the directions below.

Secure bolts completely after adjusting the tail belt, making sure that the tail output shaft is exactly 90° to the main rotor shaft.

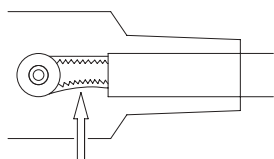
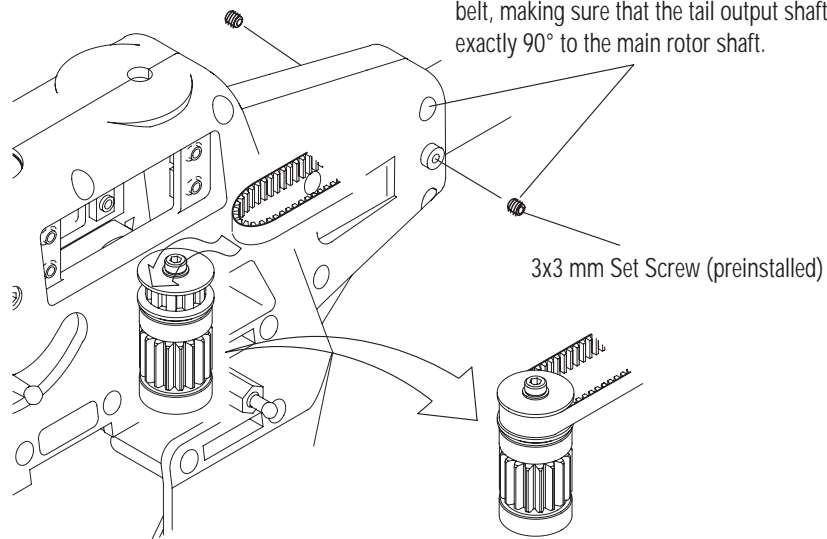

Belt tension should be set so when pressing with your finger, the sides of the belt do **not** come in contact with each other. If unsure, it is always better to set the belt tension too tight than too loose.

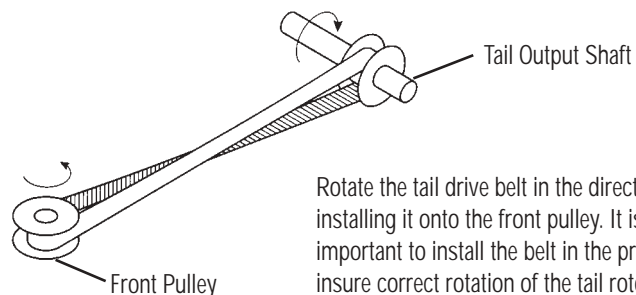

Rotate the tail drive belt in the direction shown before installing it onto the front pulley. It is extremely important to install the belt in the proper direction to insure correct rotation of the tail rotor blades.

1-3

TAIL BOOM BRACE INSTALLATION

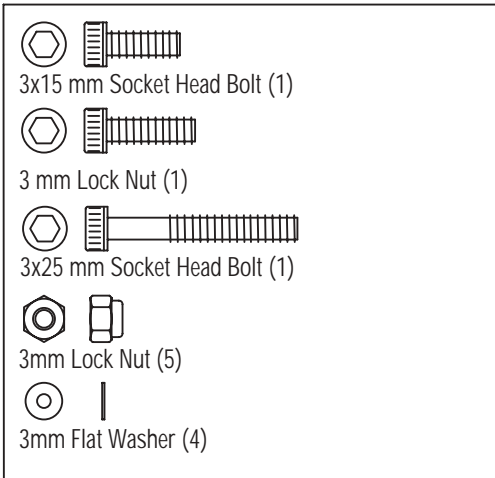

3x15 mm Socket Head Bolt (2)

It may be necessary to loosen these bolts to reposition the tail brace clamp as needed.

Tail Brace Clamp U/D

3 mm Lock Nut

3 mm Flat Washer (2)

Preassembled

3 mm Lock Nut (2)

3x7x3 mm Spacer

3x25 mm Socket Head Bolt

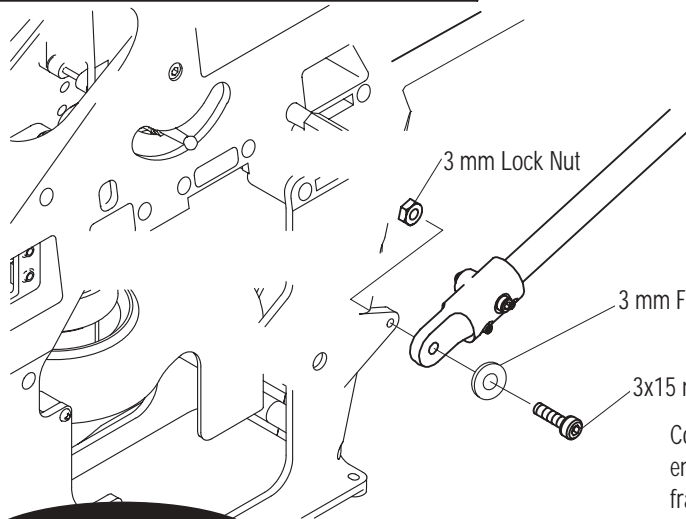

Tighten this bolt after the brace has been connected to the rear of the frame.

1-4

TAIL FIN ATTACHMENT

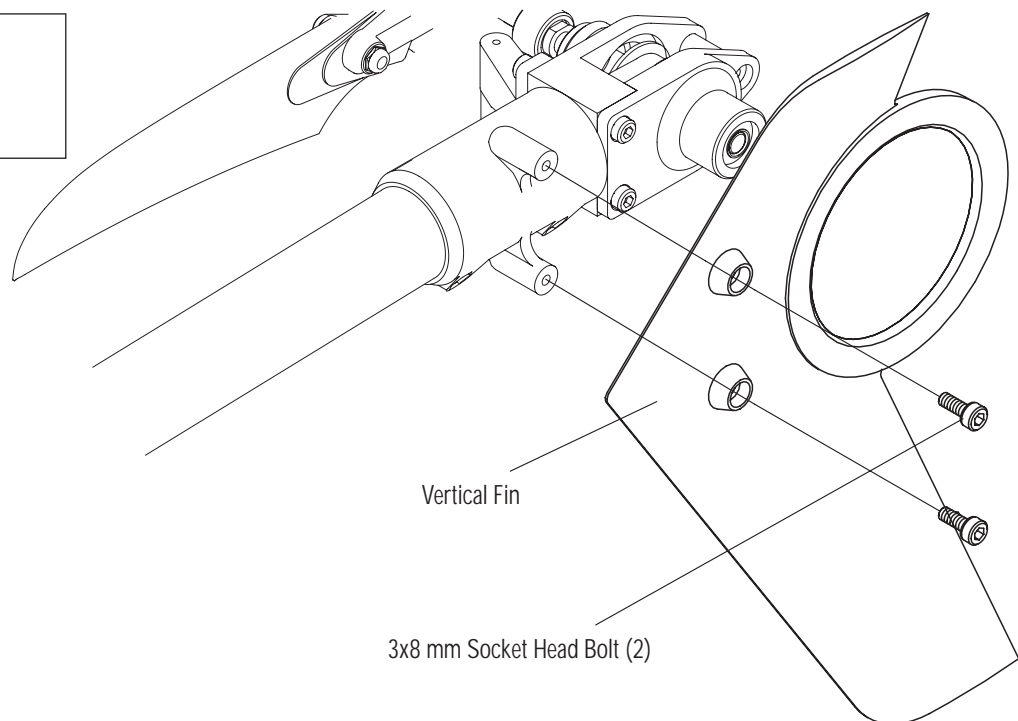
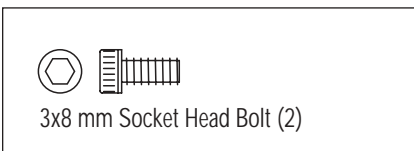

2-1

ENGINE MOUNT/COOLING FAN INSTALLATION

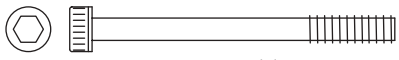

3x30 mm Socket Head Bolt (4)



3 mm Lock Nut (4)



3 mm Flat Washer (4)



3 mm Spring Washer (4)



Use Threadlock

*It is recommended that a crankshaft locking tool be used to properly secure the cooling fan assembly to the engine.

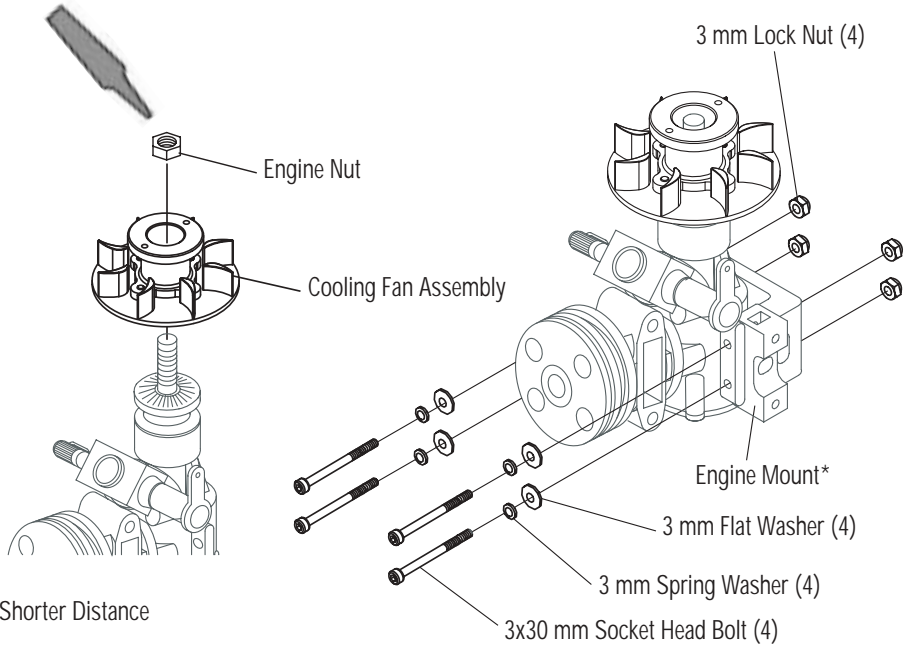
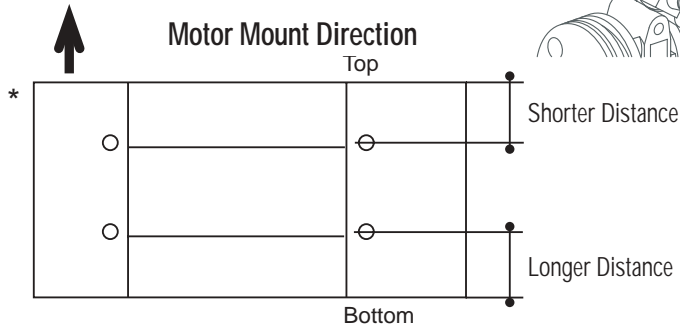

It is important to note the proper direction for the motor mount installation for achieving the correct alignment of the engine.

2-2

CLUTCH ASSEMBLY ATTACHMENT



2x8 mm Flat Head Screw (1)



3x5 mm Socket Head Bolt (2)



2 mm Hex Nut (1)



Steel Joint Ball (1)



Use Threadlock

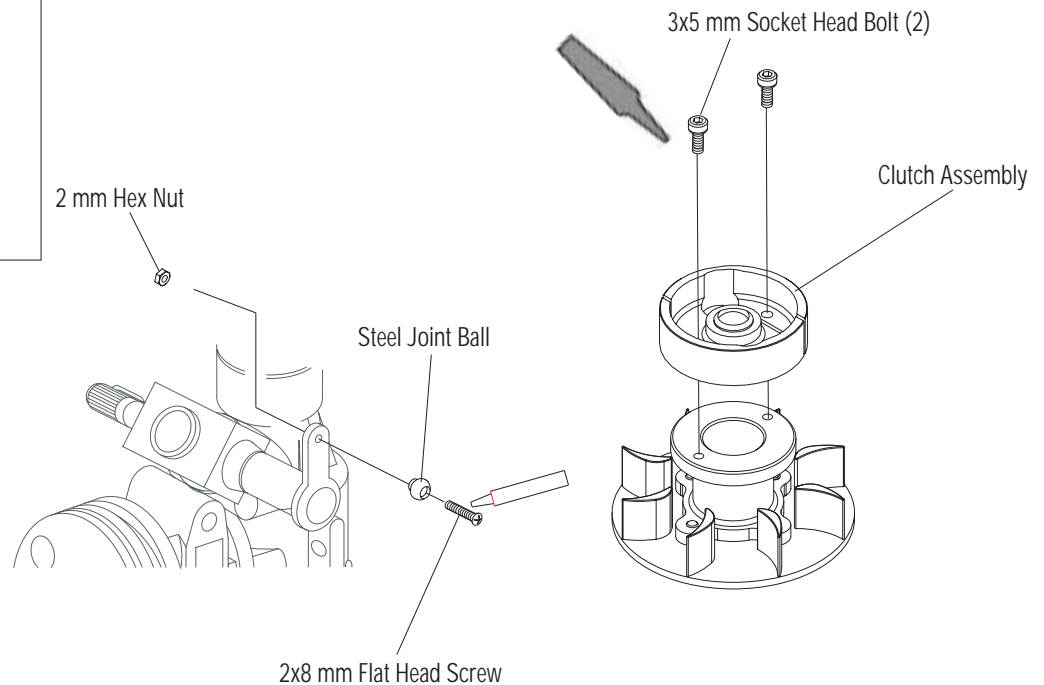

2-2

CLUTCH ASSEMBLY ATTACHMENT

Continued

To insure smooth operation, it is suggested that the clutch assembly be checked for trueness (runout) prior to final attachment. Place the engine assembly on a flat surface using the engine mount to steady the engine. While viewing the assembly straight on, rotate the fan/clutch assembly while watching the 1-way bearing located in

the center of the clutch. Note the side-to-side movement (wobble or run-out). Next loosen the two 3x5 mm clutchbolts and rotate the clutch 180° on the fan. Re-test and note the runout in this position. Choose the position that shows the least amount of visual runout and secure the clutch using the two 3x5 mm bolts (use threadlock).

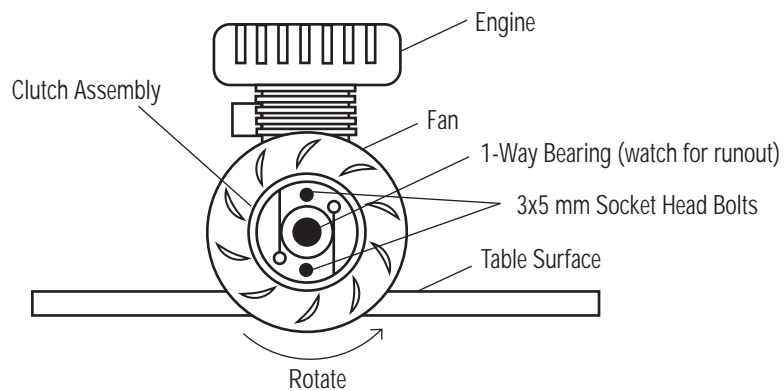

2-3

STARTER SHAFT/HEX ADAPTOR INSTALLATION



Insert the start shaft as shown and secure the hex adaptor to the shaft using the 4x4 mm set screw. Position the start shaft so that there is no up/down play.

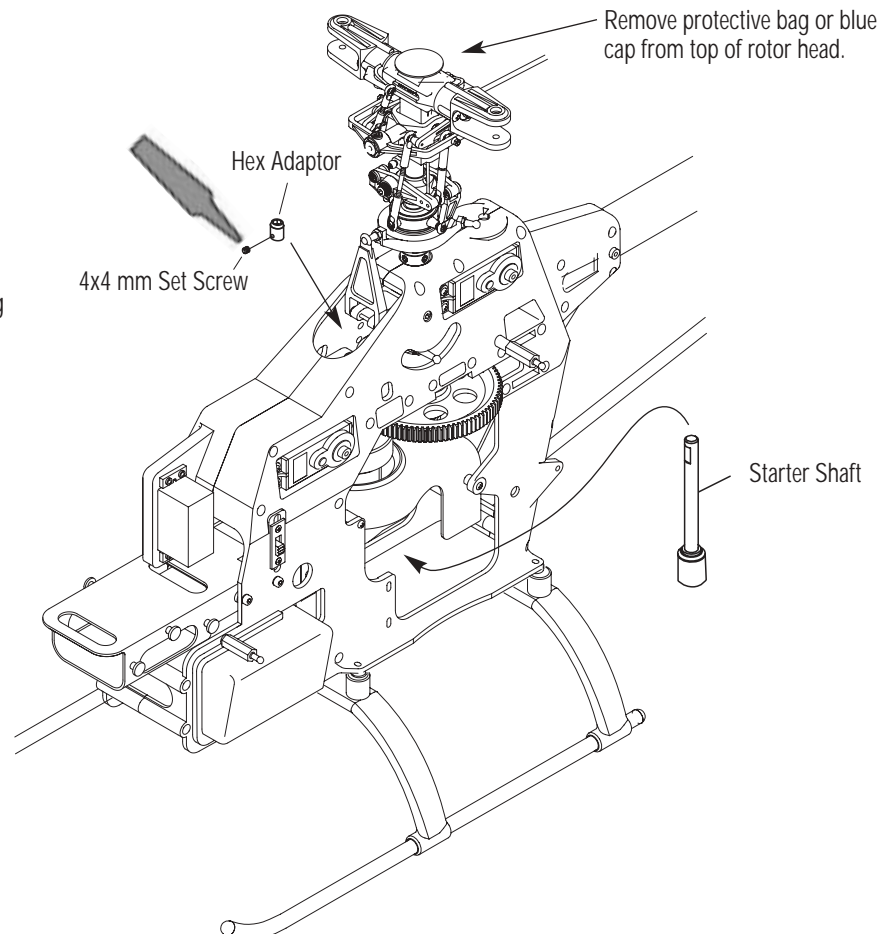

2-4

ENGINE INSTALLATION

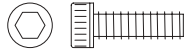

3x15 mm Socket Head Bolt (4)

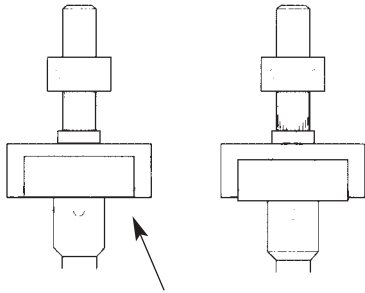

Adjust the height and position of the engine as shown so the bottom of the clutch assembly is flush with the bottom of the clutch bell. Also check to insure that the engine and clutch bell are parallel.

*It is highly recommended that you insert the muffler bolts into the engine case prior to installing the engine in the frame.

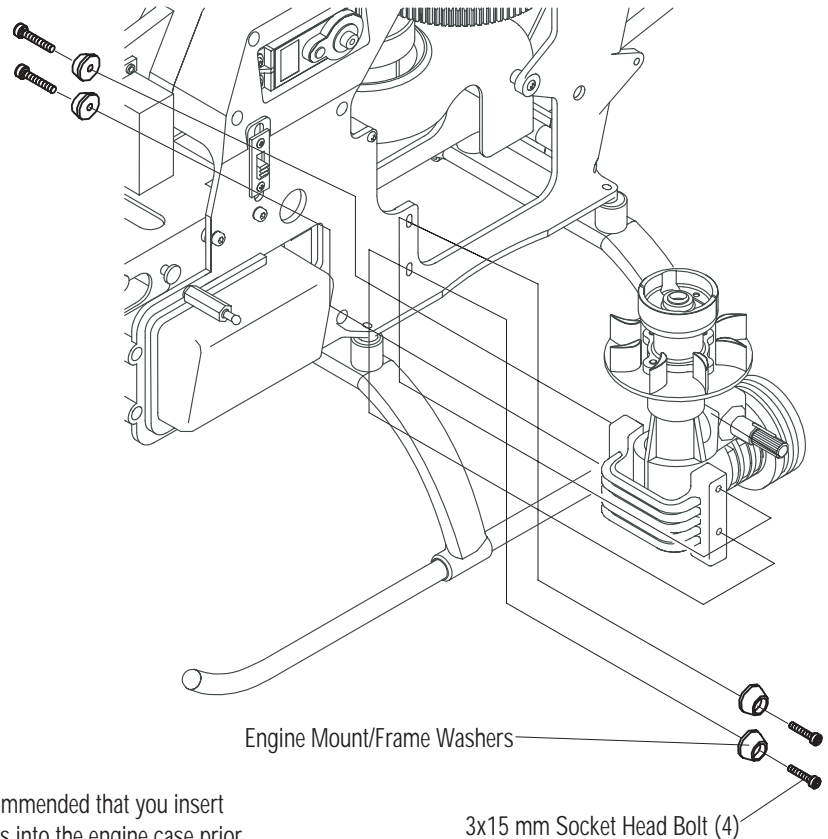

2-5

MUFFLER/HEADER TANK INSTALLATION

Fuel line connections:

- Main tank pickup line to top nipple of Header tank
- Header tank pickup line to carburetor nipple
- Main tank overflow to muffler pressure nipple

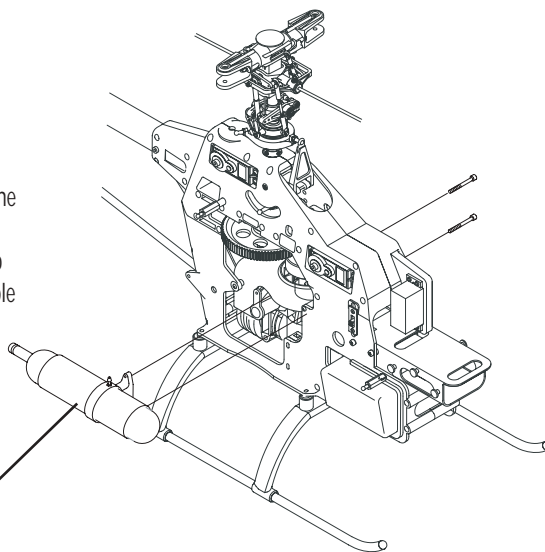

Revolution .50 Heli Muffler Shown (RVO1150) (purchased separately)

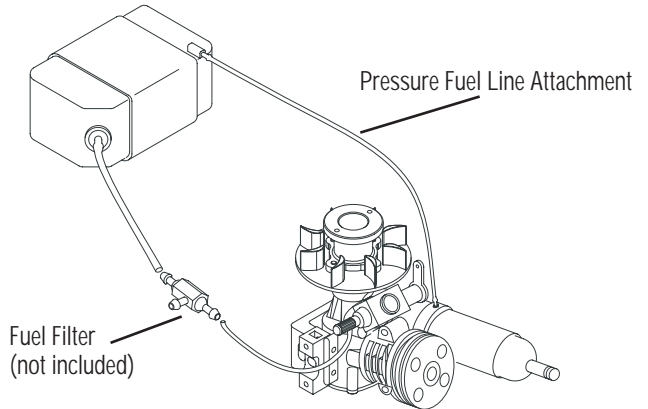

Fuel Filter (not included)

Pressure Fuel Line Attachment

Please refer to the photo for proper Header Tank plumbing and attachment

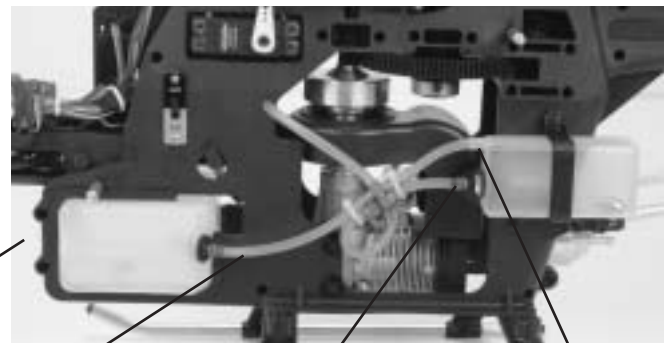

Main Tank Pickup Line

Header Tank Pickup Line

Header Tank Nipple

3-1

SERVO INSTALLATION



2.6 mm Flat Washer (20)



2.6x12 mm Self-Tapping Screw (20)

RADIO INSTALLATION SUGGESTIONS

Be sure to install four rubber servo grommets and eyelets to each servo prior to installation.

When adjusting control rods, be sure to adjust each universal link the same amount so as not to unthread one link too far.

Be sure to keep all servo lead wires, etc., away from all servo arms, rods, and sharp edges of the helicopter's mechanics. After final installation, group these wires together as indicated using the small nylon wire ties and the nylon spiral tubing included with this kit.

Note: It is suggested that the switch harness be installed prior to installation of the rudder servo.

Note: Once the servos are installed, check to see if the servos can be moved in the mounts. If the servos can be moved slightly, tighten the servo mounting screws until the servos remain in position.

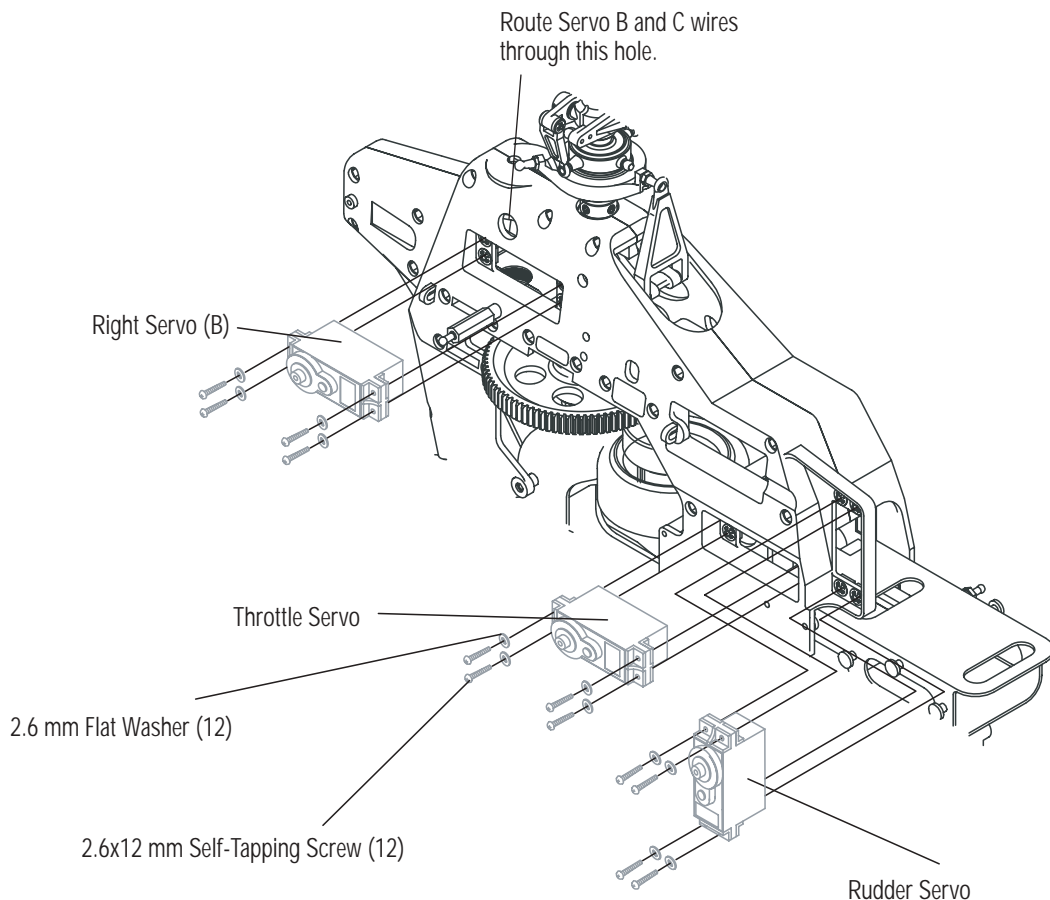
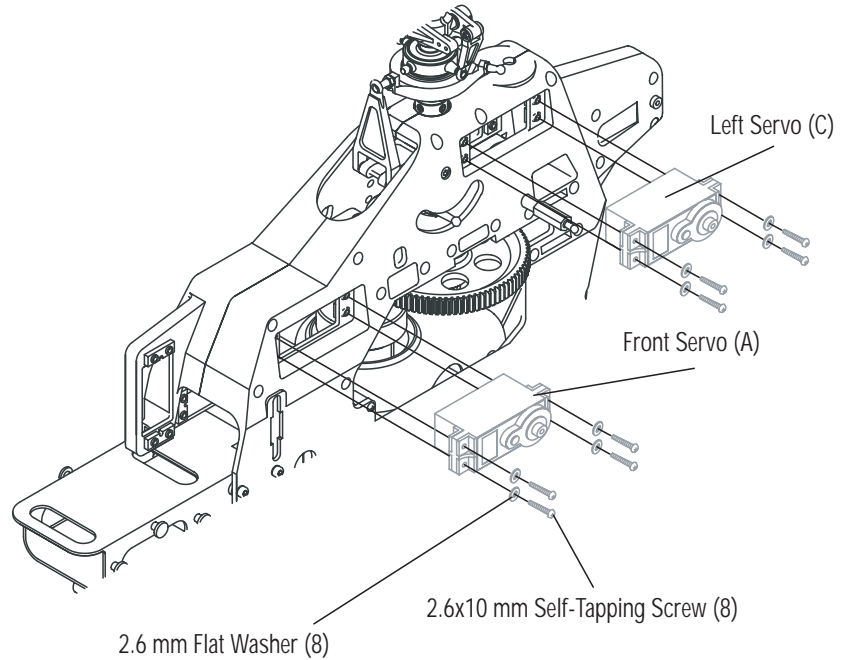

3-2

GYRO/RECEIVER/SWITCH HARNESS/BATTERY INSTALLATION

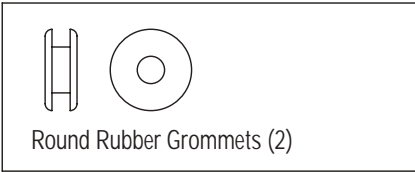

It is suggested that both the receiver and gyro amplifier be isolated from vibration by wrapping them in foam, then securing them to the model using double-sided servo tape.

Be certain when installing the gyro to the gyro mounting plate that it does not come in contact with the frame of the helicopter and that the mounting surfaces are free from oil, residue, etc. Clean if necessary to ensure proper adhesion.

Install the switch harness with the switch plate screws through the round rubber grommets before the servos are installed.

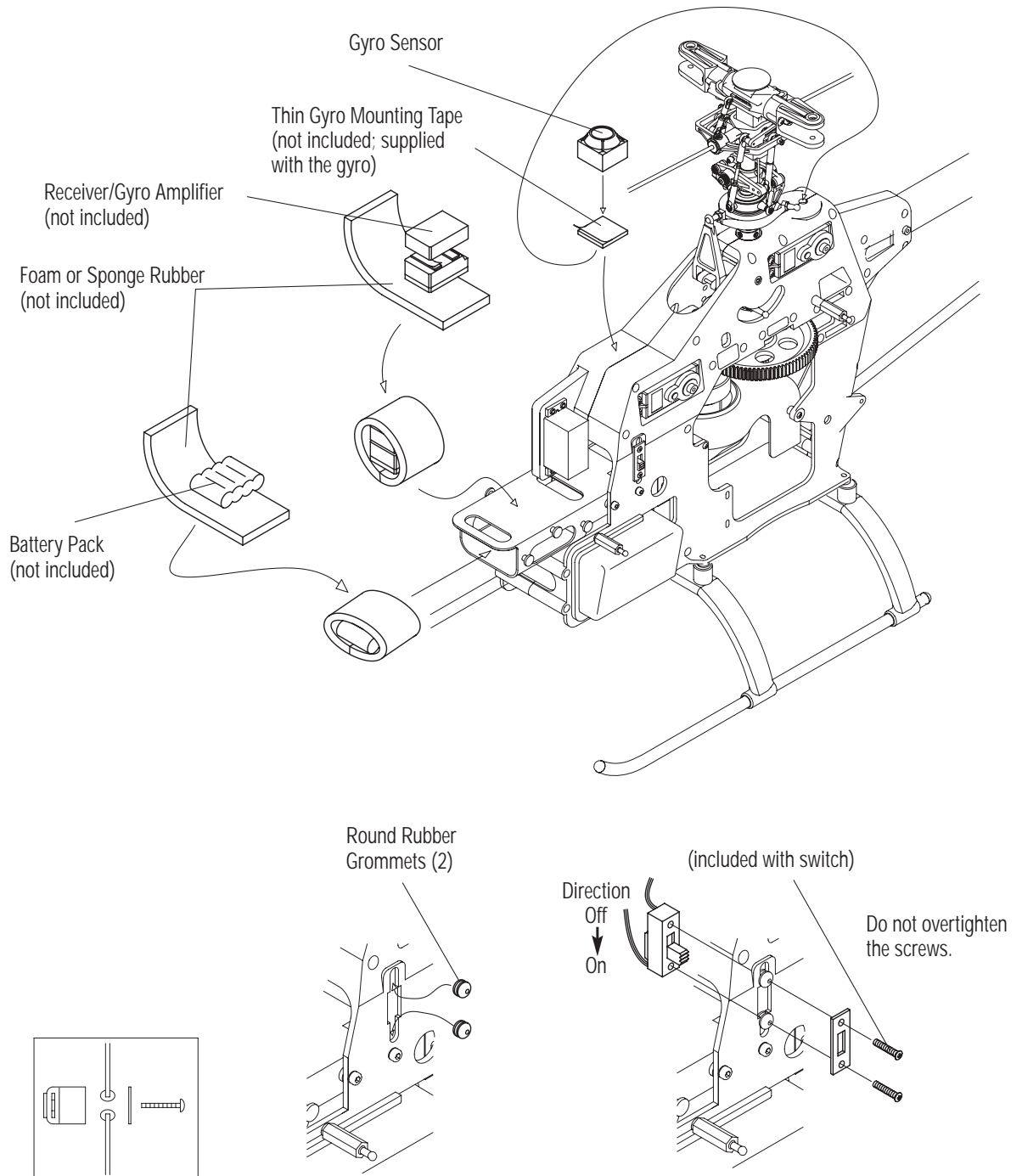

Note: With some smaller switch harnesses, it will be necessary to omit the rubber grommets for proper installation.

Wrap the servo leads with the included servo spiral wrap and route as shown.

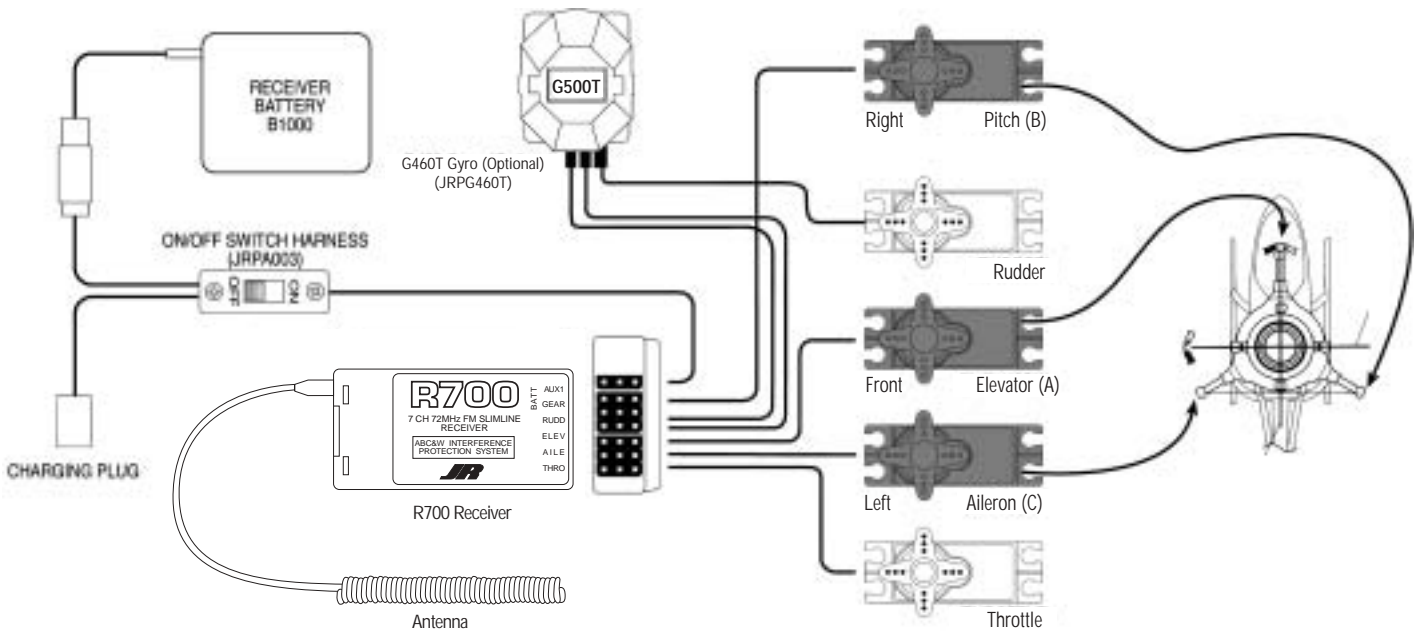
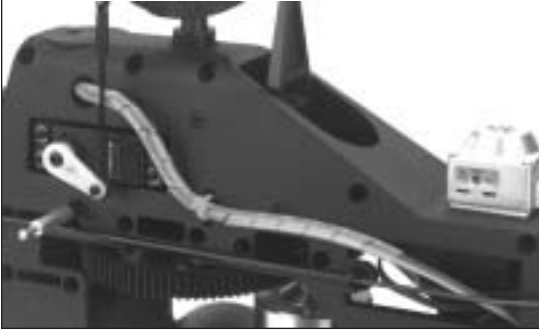

Currently, there are several different types of control systems available on the market. Although the mechanical methods for transferring control to the swashplate vary, the different control systems can be broken down into two categories:

One-Servo (Conventional)

CCPM (Cyclic/Collective Pitch Mixing)

The following is an explanation of the two most popular types of swashplate control.

One-Servo Standard Swashplate Control (Conventional Helicopter)

The One-Servo standard system is found in a wide variety of radio controlled helicopters. The term "One-Servo" means that the control system requires one servo to operate each separate swashplate function. With this system, a total of three servos is required to operate the three main swashplate functions, which are aileron (roll), elevator (pitch), and collective functions. With this type of control system, each servo works independently and is assigned to a specific function. In other words, the aileron (roll) servo is assigned to move only the aileron (roll) function, as is the elevator (pitch) servo, etc. Since these servos operate completely independently of each other, the servo torque to each control surface is limited to the maximum torque rating of the servos used.

The One-Servo standard system swashplate is designed so that the lower swashplate ring control balls are spaced at 90° to each other. This system is also most commonly arranged so that the aileron (roll) axis of the swashplate is positioned at 90° to the main mechanics of the helicopter, and the elevator (pitch) axis is parallel to the mechanics. Please refer to the diagram at right for clarification.

With this type of system, it is necessary for the helicopter to be designed using an intermediate mechanical mixing system so that the control inputs can be transferred from the three independent servos to the swashplate in such a manner that the three controls can be achieved. This mechanical mixing system allows the swashplate to both roll (aileron) and pitch (elevator), as well as slide up and down the main rotor shaft for collective pitch inputs. These mechanical mixing systems generally require the use of many ball bearings and control rods to achieve this result.

Standard "One-Servo" Swashplate System

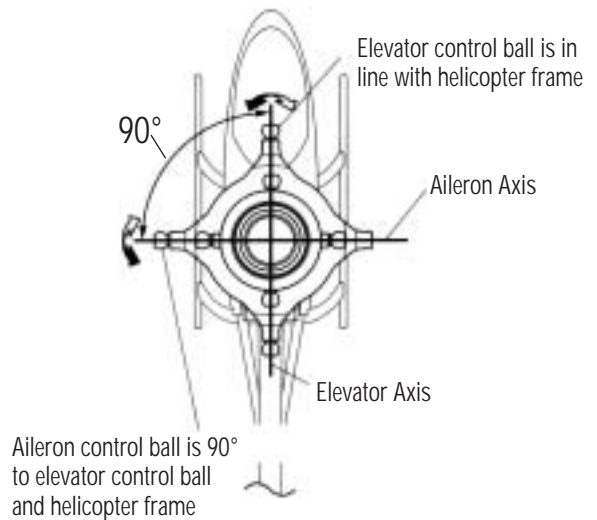

120 Three-Servo CCPM Swashplate Mixing (Venture 30 CP)

The JR 120° CCPM or Cyclic/Collective Pitch Mixing, system offers the user a control system that can accomplish the same control inputs as the One-Servo standard system mentioned above, but with increased precision and reduced complexity.

As with the One-Servo system, the JR CCPM system utilizes three servos for the three main controls: aileron (roll), elevator (pitch) and collective. The CCPM lower swashplate ring is designed with only three control balls, spaced at 120° from each other, hence the 120° CCPM designation. Although the control balls are not at 90° as in the standard system, the aileron (roll) axis is still parallel to the main mechanics of the helicopter, and the elevator (pitch) axis still functions at 90° to the mechanics as does the One-Servo system. Please refer to the diagram below for clarification.

The main and important difference in the way that these two systems operate is that unlike the One-Servo system where the three servos work completely independent from each other, the CCPM systems work as a team to achieve the same control inputs. For example, if an aileron (roll) input is given, two servos work together to move the swashplate left and right. If an elevator (pitch) input is given, all three servos work together to move the swashplate fore and aft. For collective, it's also the strength of three servos that will move the swashplate up and down the main rotor shaft. With two to three servos working at the same time during any given control input, servo torque is maximized and servo centering is also increased. In addition to these benefits, CCPM achieves these control responses without the need for complex mechanical mixing systems that require many more control rods and parts to set up.

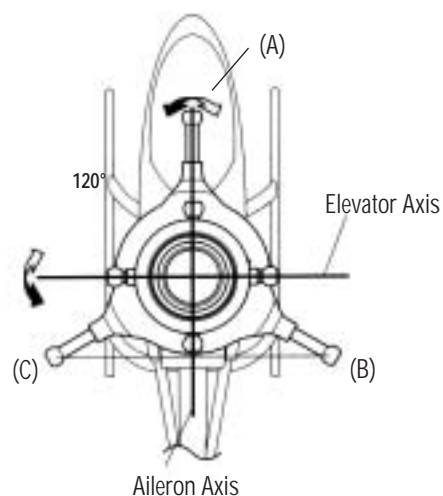

JR 120° 3 Servo CCPM Control System

This amazing CCPM control is achieved through special CCPM swashplate mixing that is preprogrammed into many of today's popular radio systems. Since the 120° CCPM function is preprogrammed, CCPM is no more complicated to set up than a conventional one-servo standard system. When you factor in the reduced parts count and easy programming, CCPM is actually easier to set up and operate than many conventional systems.

For JR radio owners, please refer to the radio information contained at the front of this manual or on the following page to determine if your radio system has the CCPM function. For other brands of radio systems, please contact the radio manufacturer for CCPM information. Please note that it is not possible to program a non-CCPM radio system for CCPM operation.

HOW JR 120 CCPM WORKS

JR 120° Three-Servo CCPM relies on the radio's special CCPM swashplate mixing, rather than a conventional mechanical mixer that is utilized to achieve the same results.

The radio's 120° Three-Servo CCPM function automatically mixes the three servos to provide the correct mixing inputs for aileron (roll), elevator (pitch), and collective. The following is an example of how each control input affects the servo's movement:

1. Collective

When a collective pitch input is given, all three servos (A, B, and C) move together in the same direction, at equal amounts, to raise and lower the swashplate while keeping the swashplate level. During this function, all three servos travel at the same value (100%) so that the swashplate can remain level during the increase and decrease in pitch. This mixing of the three servos is achieved through the radio's CCPM program.

2. Elevator (Pitch)

When an elevator input is given, all three servos must move to tilt the swashplate fore and aft, but their directions vary. The two rear servos (B and C) move together in the same direction, while the front servo (A) moves in the opposite direction. For example, when an up elevator (back cyclic) command is given, the two rear servos (B and C) will move downward, while the front servo (A) moves upward so that the swashplate will tilt aft. During this function, the front servo (A) travels at 100%, while the two rear servos (B and C) travel at 50% (1/2 the travel value) of the front servo. This difference in travel is necessary due to the fact that the position of the front control ball is two times the distance of the two rear control ball position as measured from the center of the swashplate. As mentioned, this mixing of the three servos is also achieved through the radio's CCPM program.

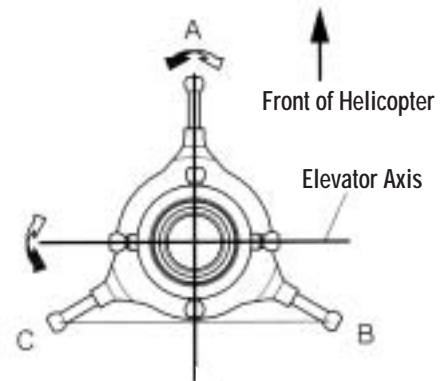

JR 120° CCPM Control System

3. Aileron (Roll)

When an aileron (roll) input is given, the two rear servos (B and C) travel in opposite directions, while the front servo (A) remains motionless. For example, when a left aileron (roll) command is given, the left rear servo (C) will move downward, while the right rear servo (B) will move upward to tilt the swashplate to the left. As mentioned, the front servo (A) will remain motionless. The travel value for each of the two rear servos is 100%.

RADIO SYSTEM REQUIREMENTS (NOT INCLUDED):

6-channel or greater R/C helicopter system with 120° CCPM function (see list below), 5 servos, 1000mAh receiver battery, and gyro

CCPM-Ready JR Radio Systems

Most current JR Heli radio systems (XP662, XP8103 w/digital trims, 10X, as well as older 10 series systems) are equipped with 120° CCPM electronics for use with the JR CCPM machines. Radios you may be flying now, like the X347, X388S, XP783, and XP8103* have CCPM capability built in, but require activation by the Horizon Service Department. Please call (217) 355-9511 for details.

*Please note that many XP8103 systems have the CCPM function already activated. Please check with the Horizon Service Center for details.

CURRENT RADIO SYSTEMS

JRP1656** PCM 10X, 5-8231 Servos (50/53/72 MHz)
JRP165TX PCM 10X, Transmitter Only (50/53/72 MHz)
JRP8622** XP8103FM, 5-517 Servos (50/53/72 MHz)
JRP8653** XP8103PCM, 5-531 Servos (50/53/72 MHz)
JRP7425** X-378 FM 5-537 Servos (72MHz)
JRP6822** XP662 FM, 5-537 Servos (72MHz)

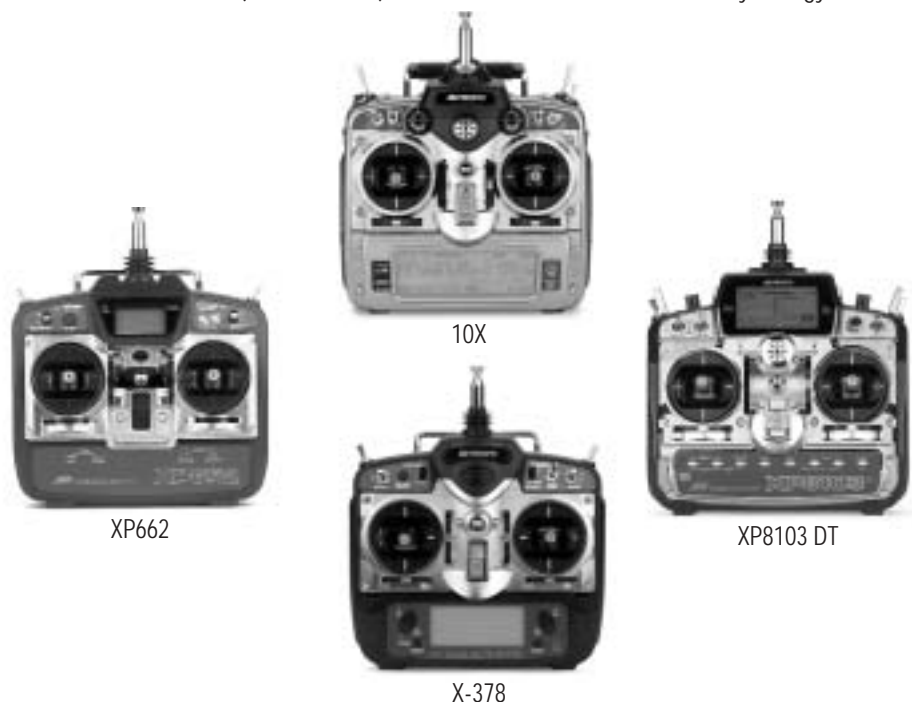

1. JR XP652/XP662 SYSTEMS

The following activation and setup procedure should be used for all JR XP652 and XP662 systems. Please note that the XF622 and XP642 6-channel systems do not have the required CCPM software and therefore cannot be activated by the Horizon Service Center.

Prior to activating the CCPM function, it is first suggested that the Data Reset function be performed to reset the desired model number to be used back to the factory default settings. If you are using a new radio system, proceed to Step C.

Caution: Prior to performing the Data Reset function, it will be necessary to select the desired model number to be used.

- A) Press the *Mode* (scroll) and *Channel* keys simultaneously while turning the power switch on to enter the System Mode. Next, press the *Channel* key until "MDL" (Model Select) appears on the screen, and choose the desired model number to be used.
- B) Press the *Mode* (scroll) key until "RST" (Data Reset) appears on the screen. Press the (+) and (-) keys simultaneously to reset the current model. A high-pitched beep will indicate that the reset was successful. Press the *Mode* and *Channel* keys simultaneously to exit the system mode.
- C) With the power switch still on, press the *Mode* (scroll) and *Channel* keys simultaneously to enter the function mode. Press the *Mode* key until "MIX CCP" (CCPM mixing) appears on the screen. Press the (+) or (-) keys to activate the CCPM function. "MIX CP2" should appear on the screen. It will be necessary to change the value of CP2, CP3, and CP6 to the values as shown below.

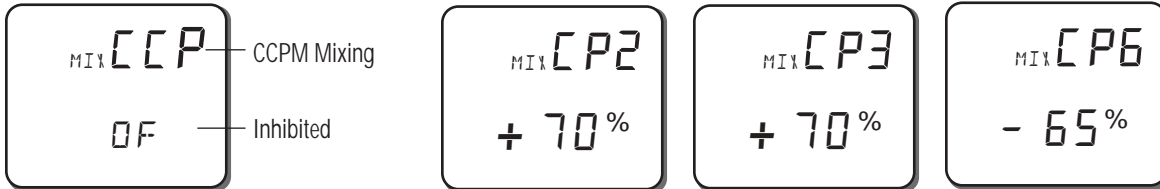
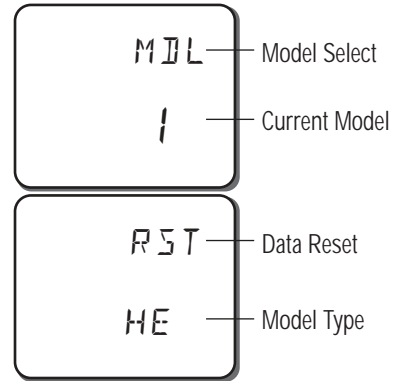

- D) Press the *Mode* (scroll) key until the servo reversing screen appears on the screen. Next, reverse the aileron (AIL) and rudder (RUD) channels by pressing the *Channel* key to select the desired channel, and then the (+) or (-) keys to set the servo direction.

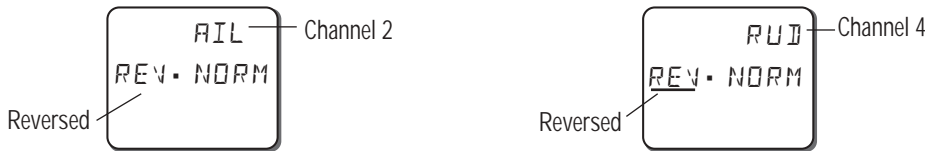

- E) Press the *Mode* (scroll) key until "TRV ADJ" (Travel Adjust) appears on the screen, and adjust the travel values as shown by pressing the *Channel* key to select the desired channel, and then the (+) or (-) key to set the desired travel value. Press the *Mode* (scroll) and *Channel* keys simultaneously or turn the power switch off to exit the function mode. Please note that the throttle travel values may vary based upon the type of engine used. This value can be fine tuned once the throttle linkage has been installed.



Note: The travel values shown for the rudder function are for use with Piezo gyros, like the JR G410T and G460T type gyros.

Proceed to page 24.

2. JR XP8103/XP8103DT SYSTEMS

The following activation and setup procedure should be used for all JR XP8103 and XP8103DT (digital trim) systems.

Note: Some early XP8103 systems will require the activation of the CCPM software through the Horizon Service Center. It's easy to identify if your system has the CCPM function activated by identifying if the "SWASH TYP" function appears in the System mode as shown in Section A below. Please refer to Section A to access the System mode.

Prior to activating the CCPM function, it is first suggested that the Data Reset function be performed to reset the desired model number to be used back to the factory default settings. If you are using a new radio system, proceed to Step B.

Caution: Prior to performing the Data Reset function, it will be necessary to select the desired model number to be used.

- A) Press the *Up* and *Down* keys simultaneously while turning the power switch on to enter the system mode. Next, press the *Up* or *Down* keys to move the cursor to the Model Select function. Press the *Up* and *Down* keys simultaneously to enter the Model Select Function. Select the desired model number to be used, then press the *Clear* key to reset the current model to the factory default settings. Press the *Up* and *Down* keys simultaneously to exit the Model Select function.

```
[SYSTEM M.]
*INFO-DISP *MODULAT
*Model SEL *TRANSFER
*MDL Name *INPUT SEL
*Type SEL *SWASH TYP
*MDL Reset
```

```
[MDL Reset]

MODEL 1
      HELI SPCM
```

- B) Press the *Up* or *Down* keys to move the cursor to the Swash Type function, then press the *Up* and *Down* keys simultaneously to access the Swashplate Type function.

```
[SWASH TYP]
1servo
  NORM

[SWASH TYP]
3servos 120°
```

Note: If the Swashplate Type function is not present, it can be activated by the Horizon Service Center. Please call for details.

Press the *Up* or *Down* keys until "3 servo 120°" appears on the screen. Press the *Up* and *Down* keys simultaneously two times to exit the Swashplate Type function and the System mode.

- C) Turn the power switch on, then press the *Up* and *Down* keys simultaneously to enter the function mode. Press the *Up* key until "SWASH MIX" appears on the screen. Once this has been completed, it will be necessary to change the values as shown using the (+) and (-) keys.

```
[SWASH MIX]
3servos
120° AILE +70%
      ELEV +70%
      → PIT. -65%
```

Adjust Pitch Value to -65%

- D) Press the *Up* key until "REV. SW." (Servo Reversing) appears on the screen. Next, reverse Channels 2 and 4 by moving the cursor with the *CH* key, then pressing the (+) and (-) keys.

```
[REV.SW]

ch 1 2 3 4 5 6 7 8
REV. █ █ █ █ █ █ █ █
NORM. █ █ █ █ █ █ █ █
```

- E) Press the *Up* key until "TRVL. ADJ." (Travel Adjust) appears on the screen. Adjust the values as shown using the channel key to move the cursor, and the (+) and (-) keys to set the value. Press the *Sel* key to access the pitch channel values and set as indicated. Please note that the required travel values will vary based on the type of servo selected. Please also note that the throttle travel values may vary based on the type of engine used. This value can be fine tuned once the throttle linkage has been installed.

```
[TRVL ADJ.]
THRO AILE PIT.
H 120% L 100% H 100%
L 120% R 100% L 100%
ELEV RUDD AUX3
D 100% L 150% + 100%
U 100% R 150% - 100%
```

Throttle travel values may vary, depending upon engine used.

Note: The travel values shown for the rudder function are for use with Piezo type gyros, like the JR G410T and G460T.

Proceed to page 24.

3. JR 10 SERIES SYSTEMS

The following activation and setup procedure should be used for all JR PCM10, 10S, 10SX, 10SXI, and 10X systems.

Prior to activating the CCPM function, it is first suggested that a Data Reset function be performed to reset the desired model number to be used back to the factory default settings. If you are using a new radio system, proceed to Step B.

Caution: prior to performing the Data Reset function, it will be necessary to select the desired model number to be used. Access the Model Select function (Code 84) and select the desired model to be used.

SET-UP PROCEDURE

- A) Access the Data Reset function (Code 28) once the correct model number has been established. Next, press the *Clear* key to reset the current model. Press the *Enter* key to exit the Data Reset function.

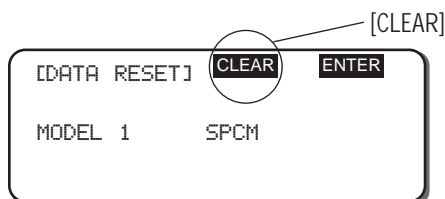

- B) Access the Swash Type function (Code 65). Next, press the *Sel* key until "3 SERVOS" (120°) appear on the screen. Once this is complete, it will be necessary to change the value of the functions from the factory default setting to the values as shown using the (+) and (-) keys below. Press *Enter* to exit the Swash Type function.

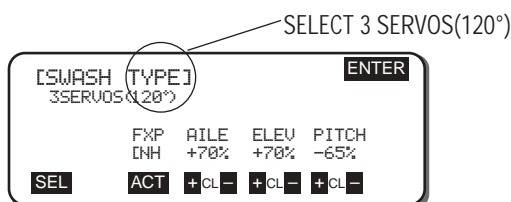

- C) Access the Servo Reversing function (Code 11). Next, reverse channels 1, 2, and 4 by pressing the desired channel number. The screen should appear as shown. Press *Enter* to exit the Servo Reversing function.

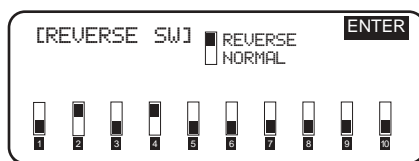

- D) Access the Travel Adjust function (Code 12) and adjust the servo travel values as shown. Please note that the required travel values will vary based on the type of servo selected. Press *Enter* to exit the Travel Adjust function.

Standard Servos

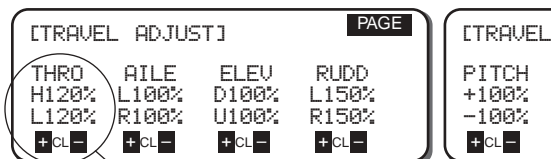

Throttle travel values may vary, depending upon engine used.

Note: The travel values shown for the rudder function are for use with Piezo type gyros, like the JR NEJ-900, NEJ-400, NEJ-450, or NEJ-3000 type gyros. If a conventional mechanical type gyro is used (JR 120, 130, etc.), then the travel value of the rudder channel will need to be reduced to approximately 100%.

Proceed to page 24.

4. JR X-378 SYSTEMS

The following activation and setup procedures should be used for all JR X-378 systems.

Prior to activating the CCPM function, it is first suggested that the Data Reset function be performed to reset the desired model number to be used back to the factory default settings. If you are using a new radio system, proceed to Step B.

Caution: Prior to performing the Data Reset function, it will be necessary to select the desired model number to be used.

- A) Press the *Down* and *Channel* keys simultaneously while turning the power switch on to enter the system mode. Next, press the *Up* key until the word "Model" flashes on the top right portion of the screen. Press the (+) or (-) keys to select the desired model number to be used. Press the *Up* key until "RESET" appears on the screen. Next, press the *Clear* key to reset the data for this model. A "beep" will be heard and the letters "CL" will flash when the *Clear* key is pressed, indicating that the data has been reset successfully.

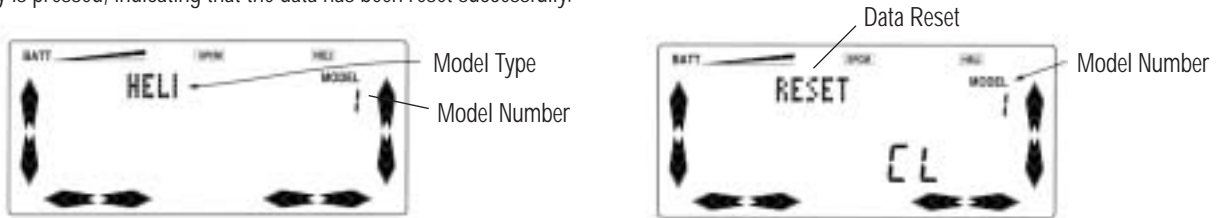

- B) Press the *Up* key until the word "SWASH" appears on the left side of the screen. Next, press the (+) or (-) keys until the word "3SERV" appears on the screen. This would indicate the selection of Three-Servo 120 Degree CCPM. Press the *Down* and *Channel* keys simultaneously to store this data and exit the System mode.

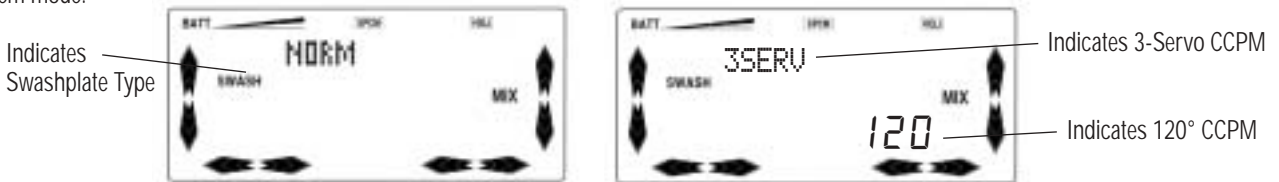

- C) Press the *Down* and *Channel* keys simultaneously to enter the Function mode. Next, Press the *Up* or *Down* keys until the words "SWASH" and "3S120" appear on the screen. Once at this screen, it will be necessary to change the values for each of the three CCPM channels as shown using the *Channel* key to select the desired channel, and the (+) and (-) keys to alter the values.

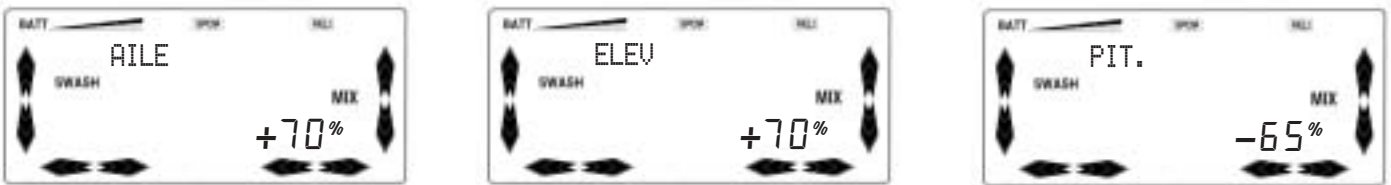

- D) Press the *Up* or *Down* keys until the word "REV." appears on the top left portion of the screen. Next, reverse the rudder and aileron channels by using the *Channel* key to select the desired channel and the (+) or (-) keys to change the servo direction from NORM to REV.

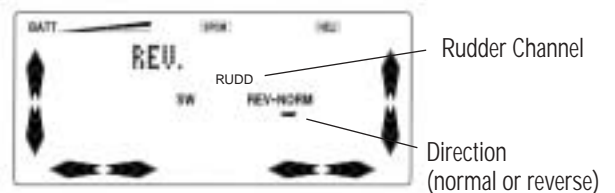

- E) Press the *Up* or *Down* keys until the word "TRAVL" appears on the top left portion of the screen. Adjust the servo travel values as shown using the *Channel* key to select the desired channel to be adjusted, and the (+) or (-) keys to increase or decrease the travel value as needed. Please note that the required travel values can vary slightly based on the type of servo selected. Please also note that the throttle travel values may vary based on the type of engine used. This value can be fine tuned once the throttle linkage has been installed.

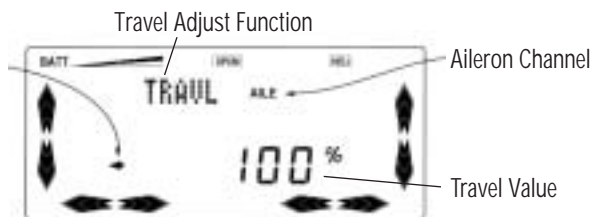



Note: The travel values shown for the rudder function are for use with Piezo-type gyros like the JR G410T and G460T.

Travel Values:	Elevator: 100/100	Pitch: 100/100
Throttle: 120/120	Rudder: 150/150	Aux2: 100/100
Aileron: 100/100	Gear: 100/100	

Proceed to page 24.

3-3

CCPM SERVO ARM PREPARATION AND INSTALLATION

-  2x10 mm Flat Head Screw (3)
-  Steel Joint Ball (3)
-  2 mm Hex Nut (3)

Use Blue Threadlock

It will be necessary to prepare three servo arms as shown in the diagram below. Prior to assembling the servo arms, the servos should be centered as indicated below, and the servo arms test fitted to the servo to insure that the arms will attach to the servo as indicated. Since the JR servo arm spline uses an odd number of teeth, it is sometimes possible to rotate the servo arm 180° to achieve a more correct positioning.

Once the best direction for the servo arm has been decided, mark the servo arm with the servo it is to be connected to (F, R, or L), as well as the side of the servo arm that needs to be removed.

It is **very** important that a heavy-duty type servo arm be used with the control ball location placed at exactly 20 mm as shown. For JR radio users, we recommend the JRPA215 Heavy-Duty Servo Arms included for this use. If a control ball position other than the specified 20 mm is used, this will create an adverse affect as to the travel of the swashplate, as well as unwanted control differential and interaction.

Prior to attaching the servo arm to the servo, it will be necessary to first turn on the radio system to center each of the three CCPM servos. It is important that the radio's collective pitch stick be set at the center position. If your radio is equipped with a hover pitch knob, please check to make sure that this knob is also in the center position at this time.

Connect the three servo arms to the three CCPM servos as shown. It is important that the servo arms be positioned parallel to the servos as shown. If the servo arm is not parallel as shown, minor centering adjustments can be made using the radio's Sub-Trim function. Please refer to Section 3-4 for more information.

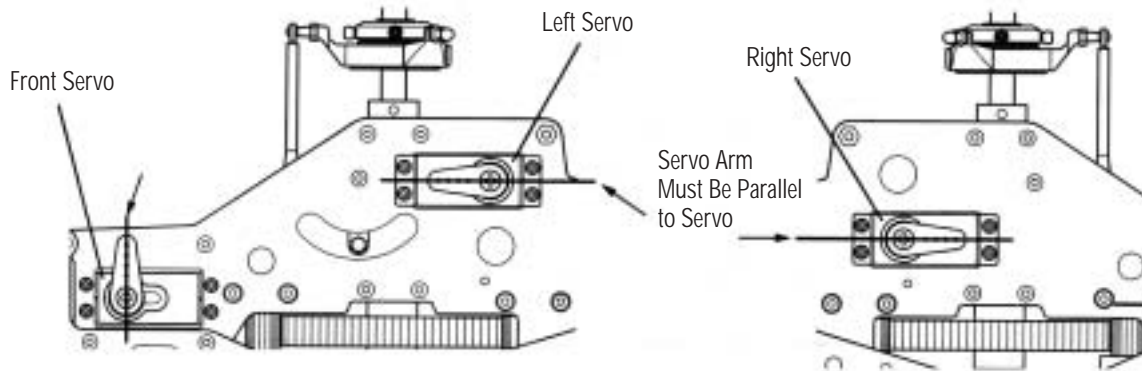
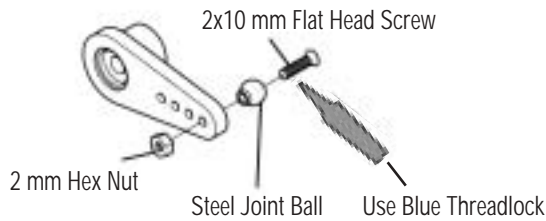
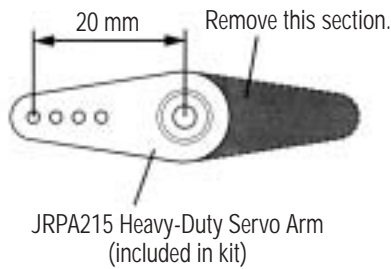

As mentioned in the previous step, it may be necessary to make minor servo centering adjustments with the use of the Sub-Trim function to achieve the desired servo arm positions. Please refer to your particular radio's section as listed below or consult your radio instruction manual for more information.

XP652/XP662 SYSTEM

- 1) With the radio power switch on, press the *Mode* and *Channel* keys simultaneously to enter the Function mode.
- 2) Press the *Mode* key until "SB-TRIM" (sub-trim) appears on the screen.
- 3) Adjust the left (aileron), right (AUX 1), and front (elevator) servos as needed until the servo arm is exactly parallel to the servo as shown when the collective stick is in the center position. It will be necessary to press the *Channel* key to access the necessary channels to be adjusted.
- 4) Press the *Mode* and *Channel* keys simultaneously to exit the Function mode.

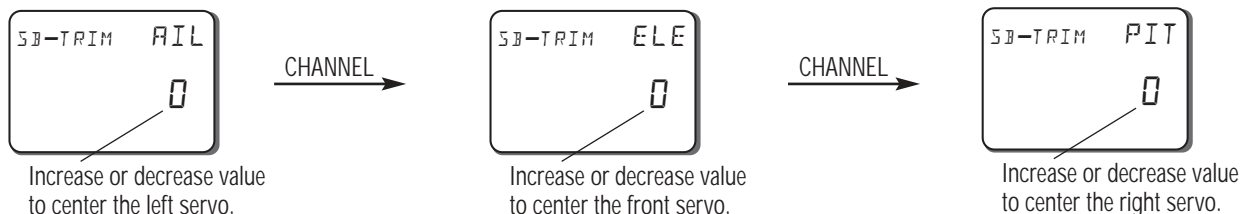

X-378 SYSTEM

- 1) With the radio power switch on, press the *Down* and *Channel* keys simultaneously to enter the Function mode.
- 2) Press the *Up* key until "SUB" appears on the screen.
- 3) Adjust the left (aileron), right (Aux1) and front (elevator) servos as needed until the servo arm is exactly parallel to the servo as shown when the collective stick is in the center position. Use the *Channel* key to select the desired channel to be adjusted, and the (+) and (-) keys to set the sub-trim value for each servo.
- 4) Press the *Down* and *Channel* keys simultaneously to exit the Function mode.

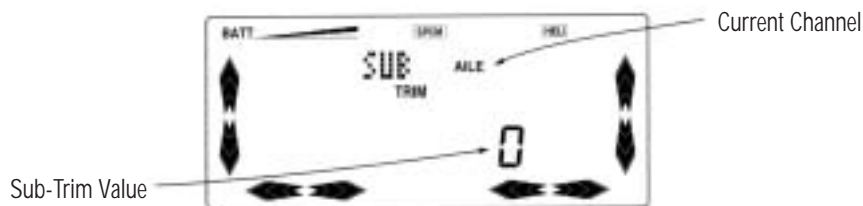

XP8103, XP8103 WITH DIGITAL TRIMS

- 1) With the radio power switch on, press the *Up* and *Down* keys simultaneously to enter the Function mode.
- 2) Press the *Up* key until "Sub Trim" appears on the screen.
- 3) Adjust the left (aileron), right (AUX 1), and front (elevator) servos as needed until the servo arm is exactly parallel to the servo as shown when the collective stick is in the center position. It will be necessary to press the *Sel* key once to access the right servo (AUX 1) sub-trim.
- 4) Press the *Up* and *Down* keys simultaneously to exit the Function mode.

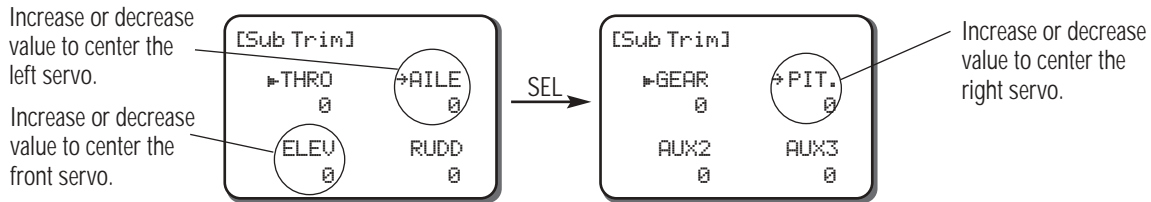

JR PCM10, 10S, 10SX, 10SXII, 10X SYSTEMS

- 1) Enter the Sub-Trim function (Code 15).
- 2) Adjust the left (aileron), right (AUX 1) and front (elevator) servos as needed until the servo arm is exactly parallel to the servo as shown when the collective stick is in the center position. It will be necessary to press the *Page* button to access the right servo (AUX 1) sub-trim value.
- 3) Press *Enter* to exit the Sub-Trim function.

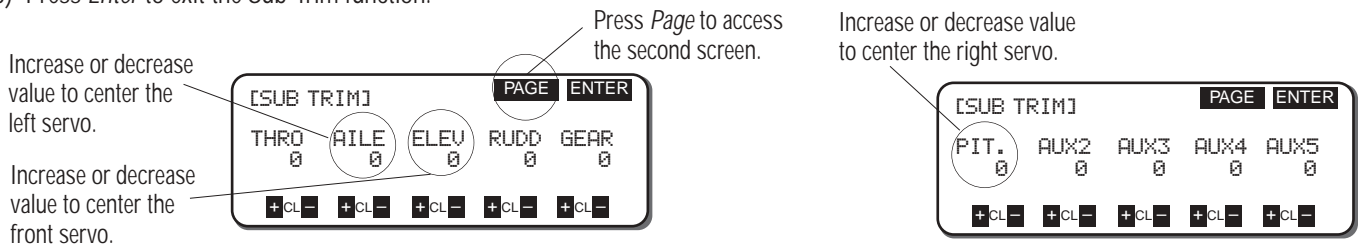

3-5

CCPM LINKAGE CONNECTION

Attach the three CCPM servo linkages as shown below. It is important that the exact distances specified below be maintained for each linkage as this is critical to the alignment and neutral position of the swashplate. Please also note the direction of the ball links as shown by the "JR Propo" name imprinted on each ball link. "JR Propo" is imprinted on the front of each ball link. When attaching the control rods, it is important to make sure that "JR Propo" faces outward as the links are attached to the control balls.

Please also note that when attaching control linkages B and C, it will be necessary to rotate the link that attaches to the swashplate slightly so that it is parallel to the rear mounting surface of the ball link. This will allow the control linkage to rotate slightly on the two control balls.

(A) Front Servo to Elevator Arm Linkage
(2.3x65 mm threaded rod)



(C) Left Servo to Swashplate Linkage
(2.3x30 mm threaded rod)

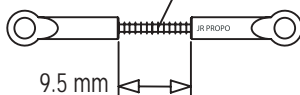

Option: For smooth operation, pre-size the ball links with the JR Ball Link Sizing Tool (JRP960219) prior to attachment.

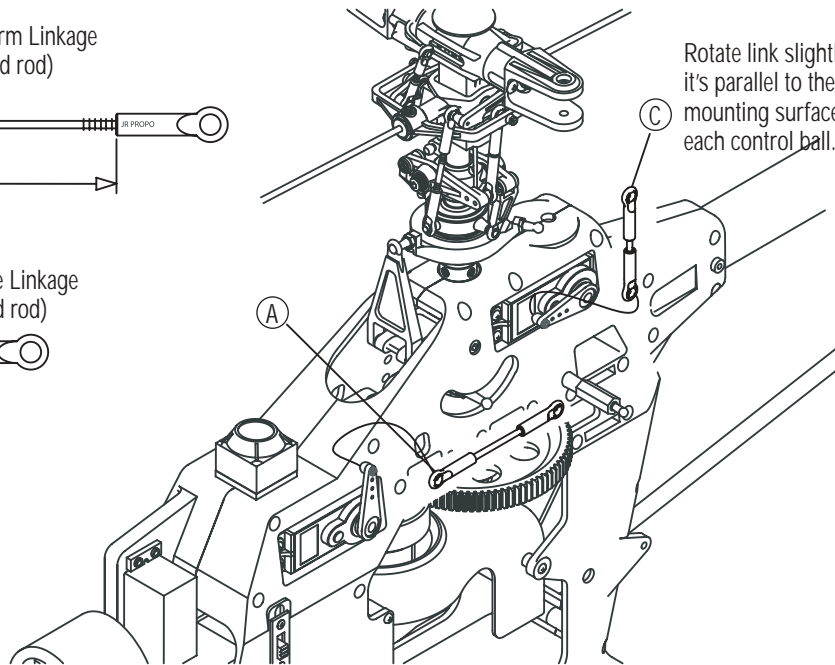

(B) Right Servo to Swashplate Linkage
(2.3x40 mm threaded rod)

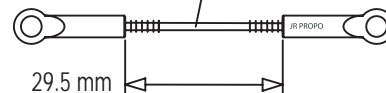

Rotate link slightly so it's parallel to the rear mounting surface of the control ball.

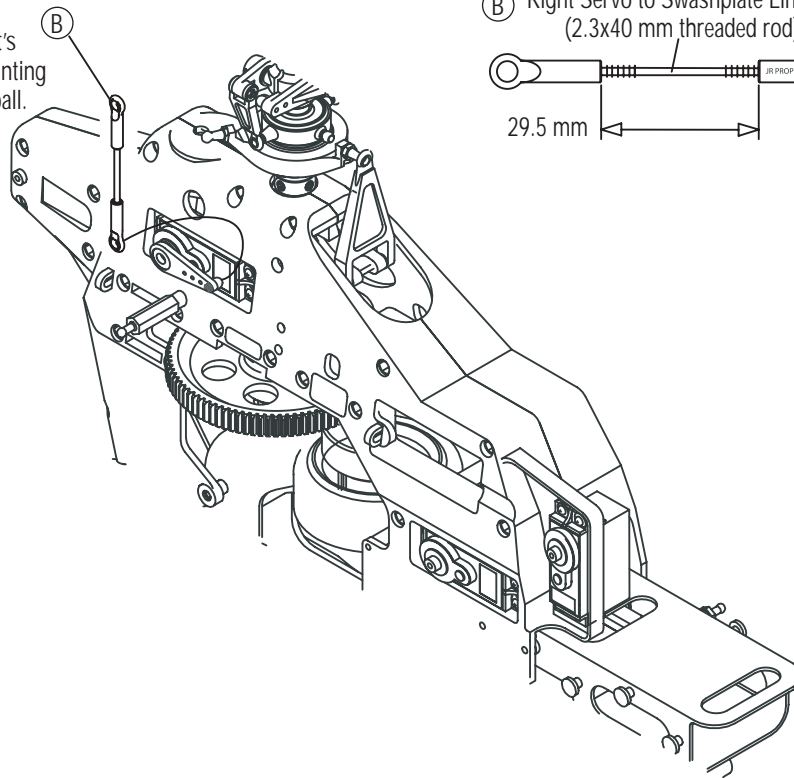

After the three control linkages have been attached to the swashplate, it will be necessary to check the swashplate to ensure that it is level. To do this, turn on the radio system and place the collective stick in the center position as before. Next, check to make sure that all trim levers and knobs are also in their center position.

Check to insure that the servo arms are parallel to the servos as adjusted in the previous step. If the servos are not parallel, please refer to the Sub-Trim section on page 26 and re-adjust as necessary. Once it's determined that the servo arms are parallel to the servos as required, it will now be necessary to check the swashplate to insure that it is also level or neutral in this position.

It is suggested that the swashplate first be checked from the rear of the model to insure that it's level from left to right. If the swashplate is not level as compared to the frame of the model, adjust either the left or right servo control rod as needed. To determine which rod needs adjustment, it may be helpful to view the swashplate from the left and right side view of the model to determine which side is high or low.

Once this left-to-right adjustment is completed, it will now be necessary to check the fore/aft position of the swashplate to insure that it is also level on this axis. If the swashplate is not level in the fore/aft axis, it is suggested that the adjustment be made to the front servo control linkage as needed. If you are unsure as to which linkage needs adjustment or are having difficulty obtaining the correct adjustment, please check the length of each control rod to insure that it is adjusted to the correct length as outlined in Step 3-5.

Note: If care was taken in the linkage attachment in Step 3-5, little or no adjustment should be required in this step. Only minor adjustments should be made to the lengths of the control linkages at this time. Any major adjustments indicates either incorrect linkage lengths or incorrect servo arm positioning. If the control linkage lengths are altered from the recommended lengths more than one or two turns, this will have a great effect on the range and settings of the collective pitch in later steps.

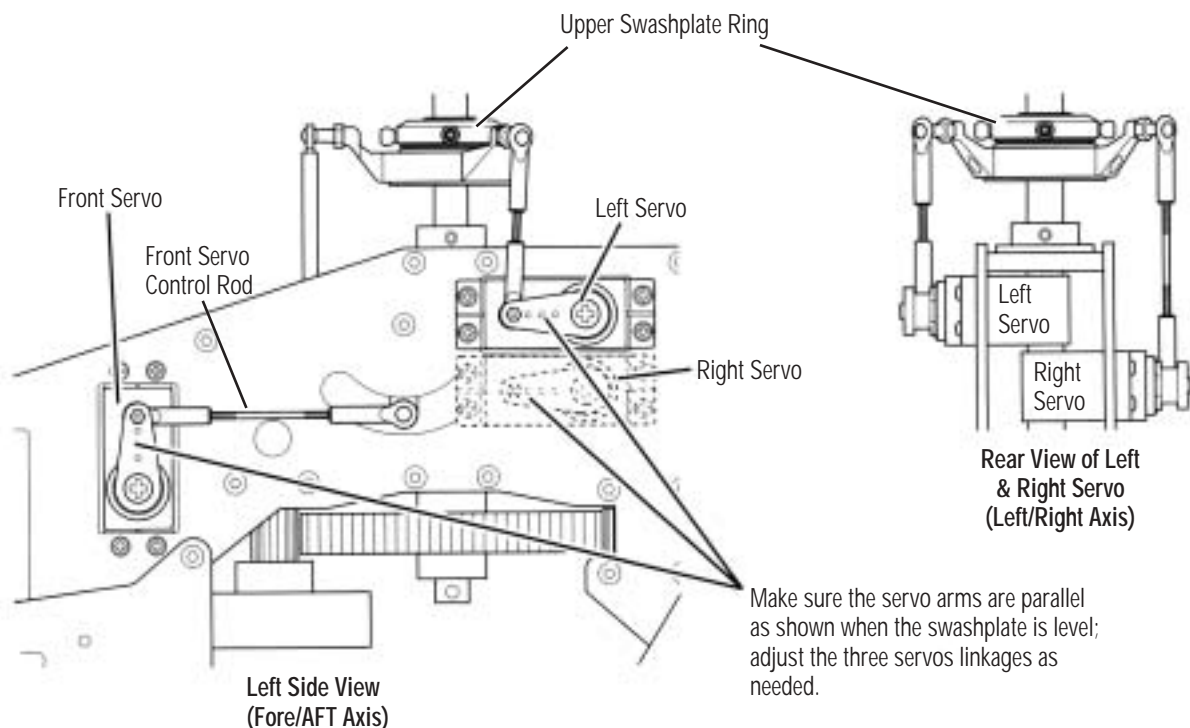

3-7

ADVANCED SETUP: PITCH-TO-AILERON MIXING ADJUSTMENT WITH TRAVEL ADJUST (OPTIONAL)

It is very possible that the travel of each servo varies slightly, which can cause the swashplate to be tilted to the left or right when the collective is moved to the extreme high and low pitch positions. This condition is generally more common when standard type servos are used. If JR digital servos are used, the adjustment required is generally very small, if any. These variations in travel can be corrected by altering the travel value of each servo slightly through the Travel Adjustment function.

To check the pitch-to-aileron mixing, it will first be necessary to position the collective stick in the center position as in the previous steps. Next, move the collective stick from the center position to the high pitch position while viewing the swashplate from the rear of the model as shown in the diagram below. While moving the swashplate, look for any tendency for the swashplate to roll to the left or right as it reaches the high pitch position. Repeat this procedure several times to be sure that your observations are correct. If no rolling tendency is found, it will now be necessary to repeat this procedure from the center collective stick position to full low pitch. If no rolling tendency is found, proceed to Step 3-8.

In our example, we have shown that the swashplate has been tilted to the right as the collective has been increased to full pitch. This would indicate that the left servo's maximum travel is greater than the right servo's maximum travel.

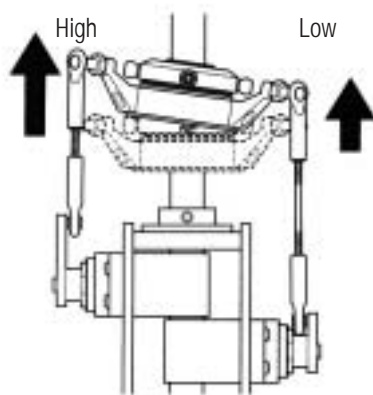

AILE= Left Servo (C)
ELEV= Front Servo (A)
AUX1= Right Servo (B)

View is shown from the rear of the model. Notice how in this example, the swashplate has tilted to the right as the collective has moved from center to full high pitch position.

In this condition, we suggest that the travel value for the left servo be reduced slightly (5–10%). Repeat the procedure above. If the same condition occurs, but to a lesser degree, then the travel value of the right servo should be increased slightly and retest. In most cases, it will require only the adjustment of the left or right servo to correct this situation.

For information on the Travel Adjustment function, please refer to your radio instruction manual for details. Once this condition has been corrected, repeat this procedure for the center to low collective pitch position and adjust as needed.

Beginners can proceed to step 3-9.

ADVANCED SETUP: PITCH-TO-ELEVATOR MIXING ADJUSTMENT WITH TRAVEL ADJUST (OPTIONAL)

The total travel of each servo can vary slightly, which can also cause the swashplate to be tilted fore and aft when the collective is moved to the extreme high and low pitch positions. This situation can also be corrected if necessary through the use of the Travel Adjustment function.

To check pitch-to-elevator mixing, it will first be necessary to position the collective stick in the center position as in the previous steps. Next, move the collective stick from the center to the high pitch position while viewing the swashplate from the left side of the model. While moving the swashplate, look for any tendencies for the swashplate to tilt fore or aft as it reaches the high pitch positions. Repeat this procedure several times to be sure that your observations are correct. If no fore or aft tilting tendencies are found, it will now be necessary to repeat this procedure from the center collective stick position to full low pitch. If no tilting tendency is found, proceed to the next step.

In our example, we have shown that the swashplate has been tilted forward as the collective has been increased to full high pitch. This would indicate that the front servo's maximum travel is now more than that of the two rear servos (left and right).

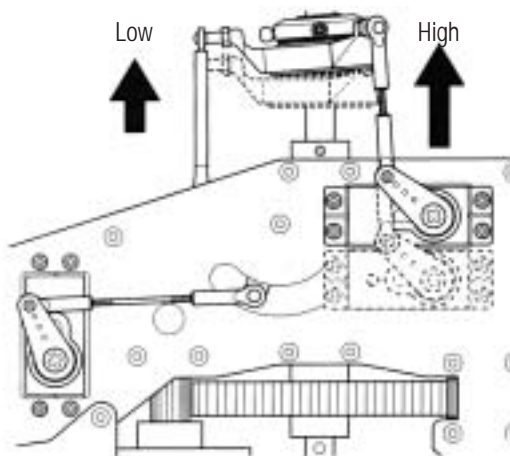

View is shown from the left side of the model. Notice how in this example the swashplate has tilted forward as the collective has moved from the center to the full high pitch position.

In this condition, we suggest that the travel value for the front servo be increased slightly (5–10%). Repeat the above procedure and increase the value as needed until the tilting tendency is eliminated.







For information on the Travel Adjustment function, please refer to your radio instruction manual for details. Once this condition has been corrected, repeat this procedure for the center to low collective pitch position and adjust as needed.

Note: It is very important that during this step, only the travel value for the front servo (elevator) be adjusted to correct any pitch-to-elevator tendencies. If the travel value of the left or right servo changes, this will affect the pitch-to-aileron tendencies corrected in the previous step. If you feel that readjustment of the left and right servo travel is necessary, then it is suggested that the travel for each servo be increased or decreased at the same amount, and the pitch-to-aileron procedure be re-tested.

Beginners can proceed to step 3-9.

3-9

TAIL CONTROL ROD SERVO CONNECTION

-   2x8 mm Flat Head Screw (1)
-   2 mm Hex Nut (1)
-   Steel Joint Ball (1)

 Use Blue Threadlock

Note: The 4th HD servo arm included in the kit can be used for the rudder servo.

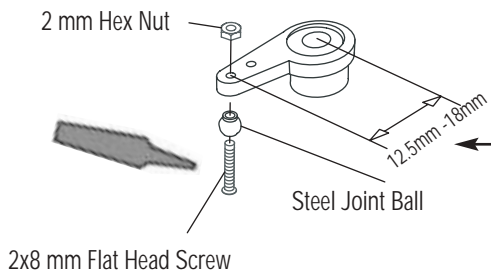
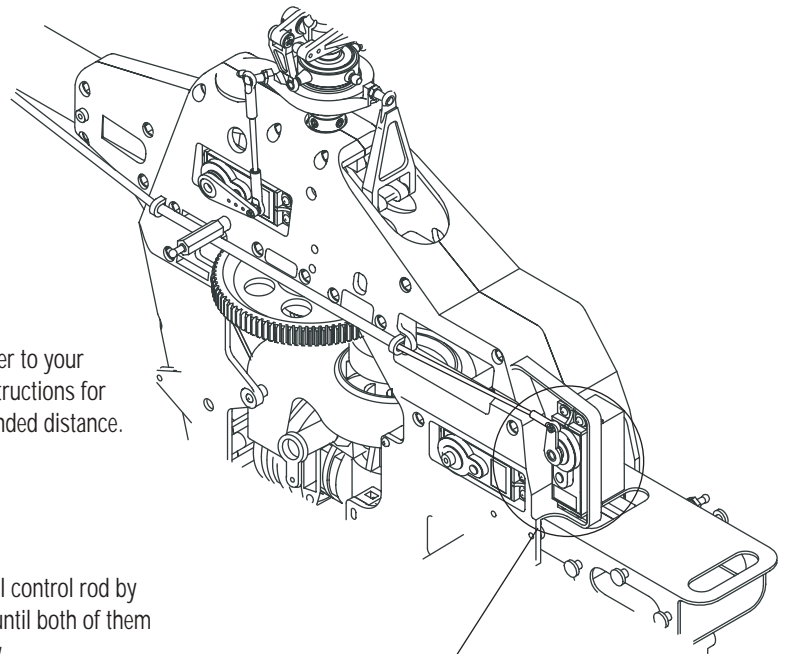

Please refer to your gyro's instructions for recommended distance.

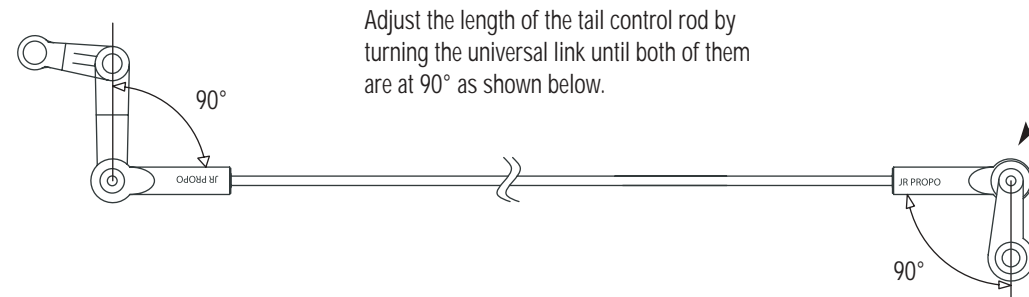



Adjust the length of the tail control rod by turning the universal link until both of them are at 90° as shown below.

Note: Check to ensure the tail control rod can slide through the tail control rod guides smoothly before connecting it to the servo. If resistance is felt, rotate the tail control rod guides slightly until the control rod slides smoothly. Once the system is adjusted to move freely, it is suggested that a small amount of CA adhesive glue be applied to secure each tail control rod guide to the tail boom in the proper location.

3-10

THROTTLE LINKAGE INSTALLATION

-  2x8 mm Flat Head Screw
-  2 mm Hex Nut
-  Steel Joint Ball

 Use Blue Threadlock

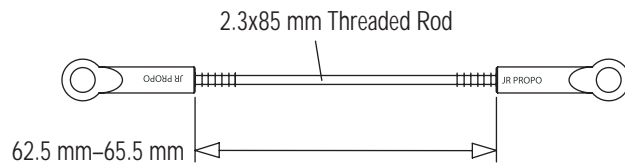
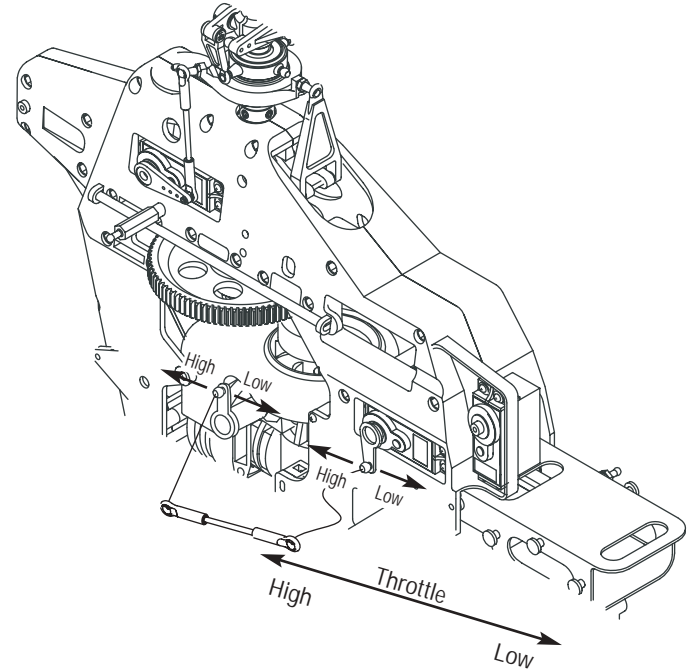
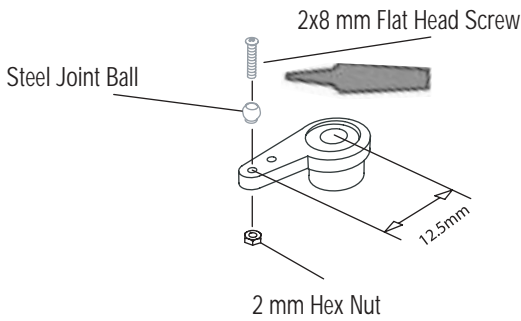

THROTTLE ARM/SERVO HORN POSITIONS

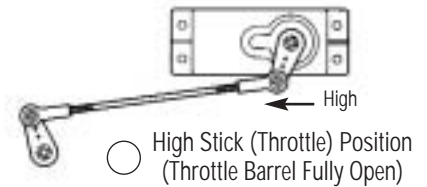

*To avoid differential throttle travel, make certain both the throttle arm and the servo horn are positioned as shown in the above diagrams.

To achieve the correct position of the throttle/servo arm, it may be necessary to re-position the throttle arm on the carburetor and to adjust the length of the throttle linkage slightly to achieve full open and closed positions of the carburetor.

It is also possible to increase/reduce the travel of the throttle servo through

the Travel Adjust function found in most computer radio systems. If this function is used, make sure the values for the high and low positions remain equal (same value for high/low). If these values are not equal, this will create a differential or uneven movement of the throttle, making rotor rpm adjustment and fine tuning more difficult.

4-1

BODY ASSEMBLY/CANOPY ATTACHMENT

Preinstalled

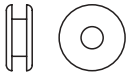

Rubber Grommet (4)



2.3x8 mm Self Tapping Screw (4)

Trim the shaded area from the windshield as shown.

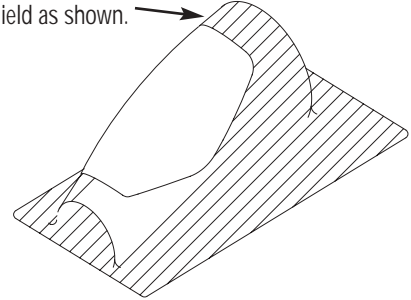

2.3x8 mm Self-Tapping Screw (4)

Rubber Grommet (4)

Canopy

Body

After trimming, attach the windshield to the body temporarily with tape. Next, drill four 1/16" holes through both the windshield and the body and secure using the 2.3x8 mm screws provided.

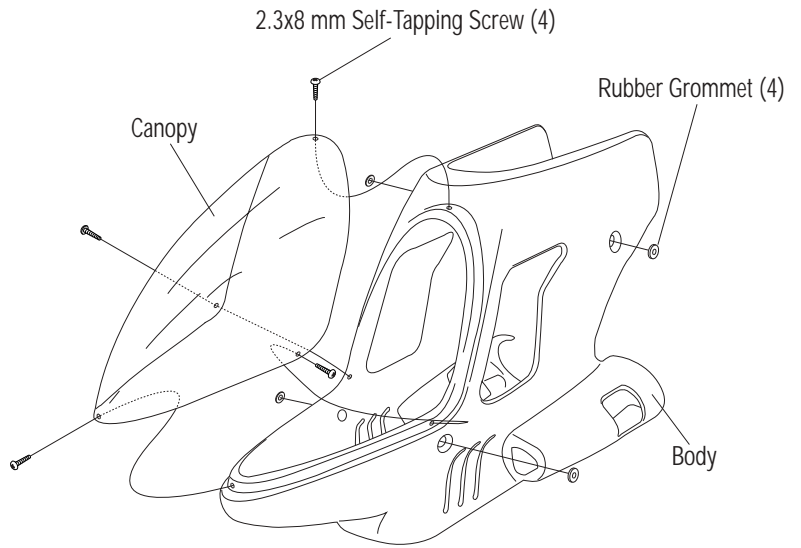

Slide the completed body over the mechanics and secure through the four canopy mount standoffs as shown.

Note: Check to insure that the body does not come contact with any portion of the main frame, muffler, servo/servo horns, etc. Trim for clearance if necessary.

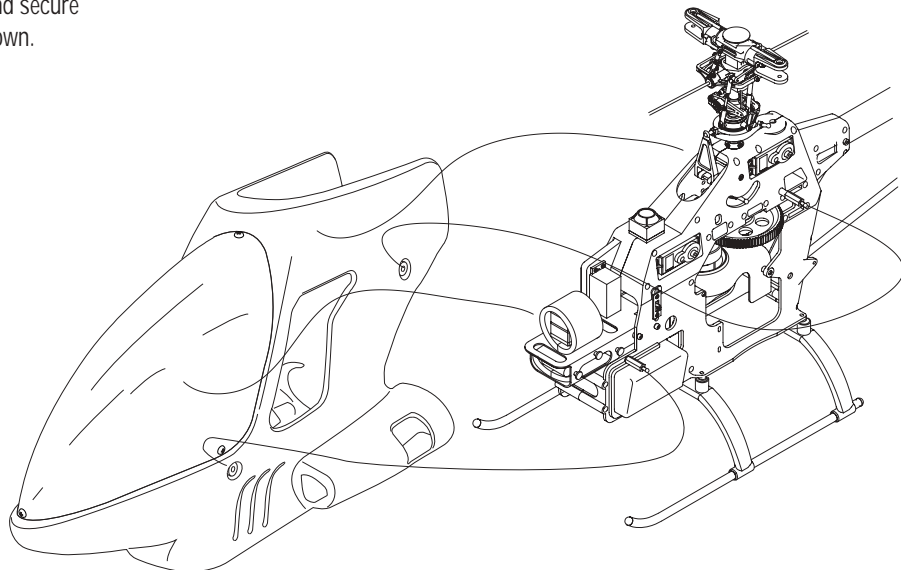

4-2

DECAL ATTACHMENT

Attach the decals as shown. It is suggested that the parts be cleaned with rubbing alcohol prior to decal attachment.

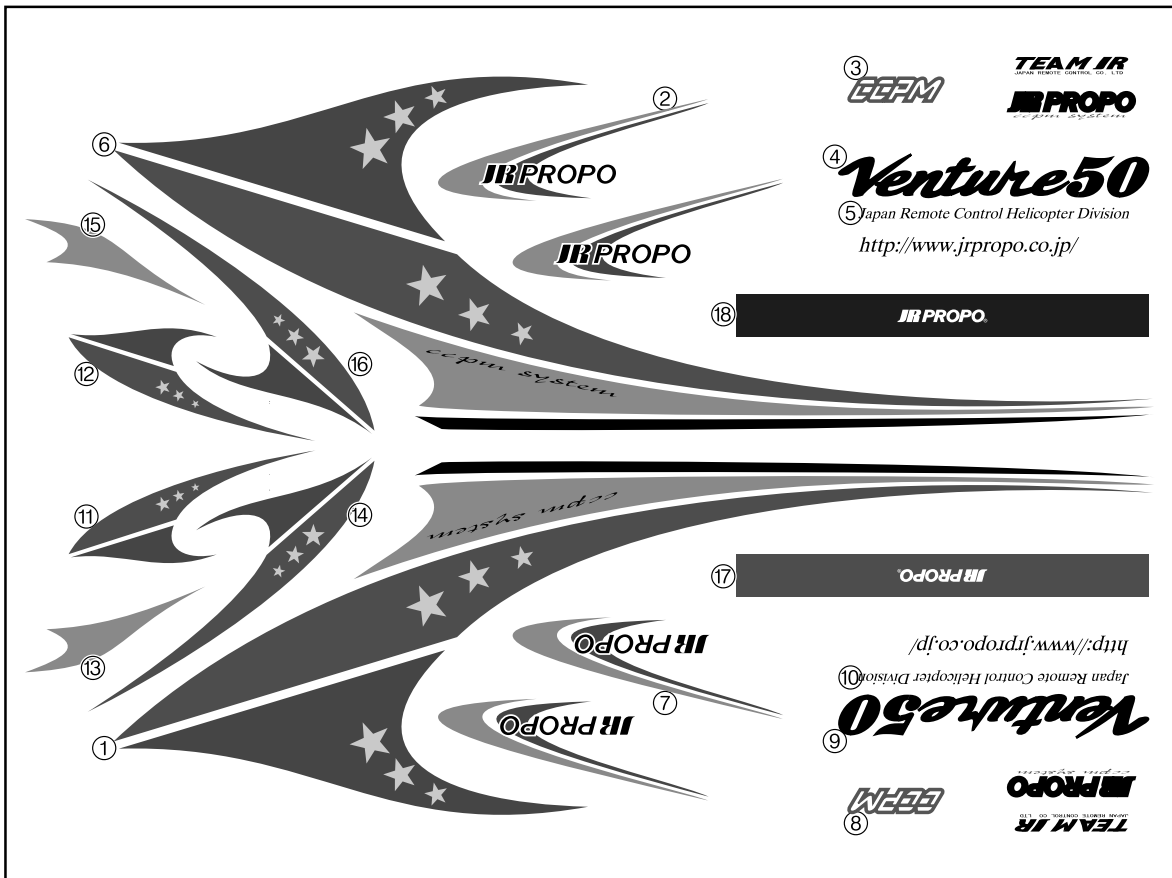
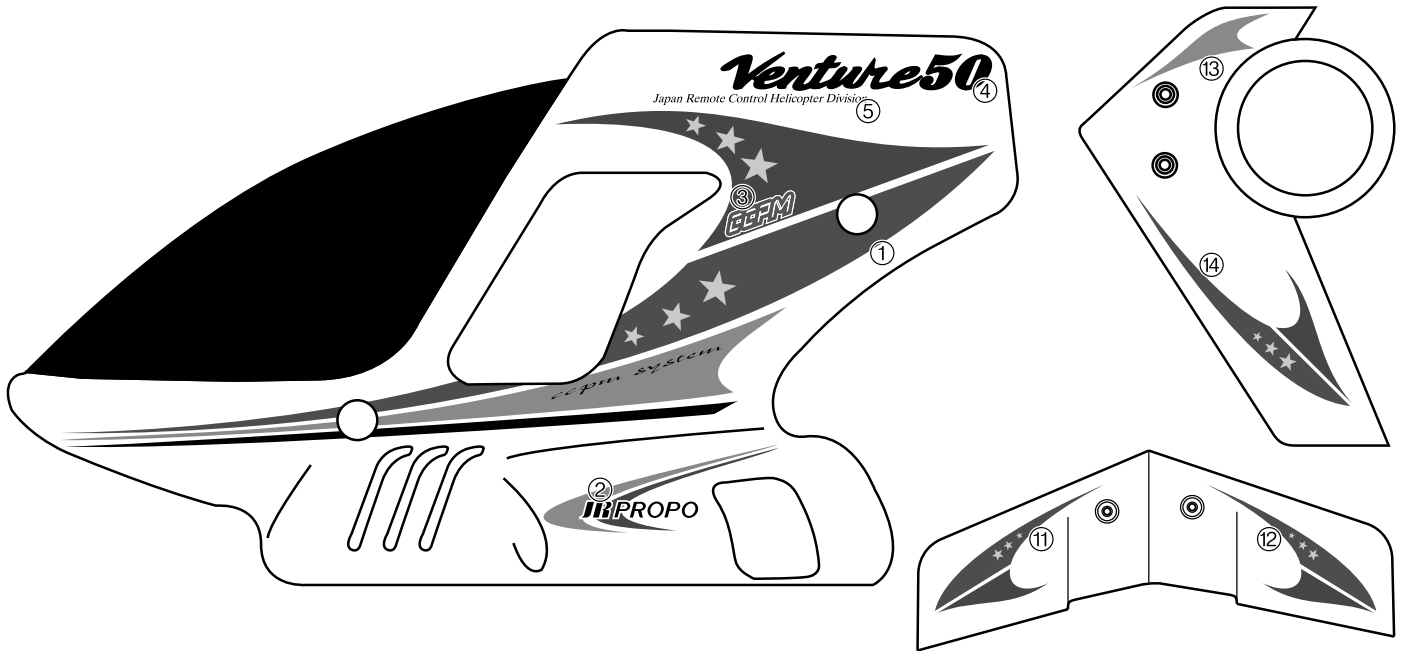

4-3

MAIN ROTOR BALANCING (ROTOR BLADES NOT INCLUDED)

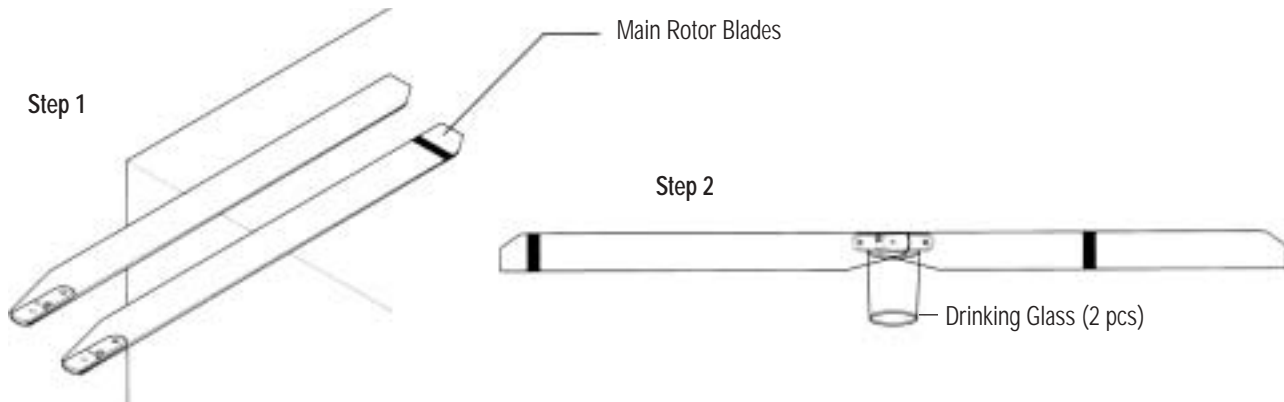

Spanwise C.G. Balancing

Place each rotor blade on a sharp edge of a table as shown and adjust so each rotor blade “teeters” on the edge of the table. If the blades are correctly balanced, they should be at an equal distance to the edge of the table. If they are not, apply tape to the center of the light or short blade until equal distance can be achieved.

Final Static Balancing

To static balance the main rotor blades, either attach each blade to a “seesaw” type Blade Balancer (KSJ528) or bolt each of the two blades together through the blade mounting holes shown and suspend this unit between two drinking glasses. Add blade tracking tape (from decal sheet) to the tip of the light or high blade until they each become level to the table surface.

4-4

MAIN ROTOR BLADE ATTACHMENT

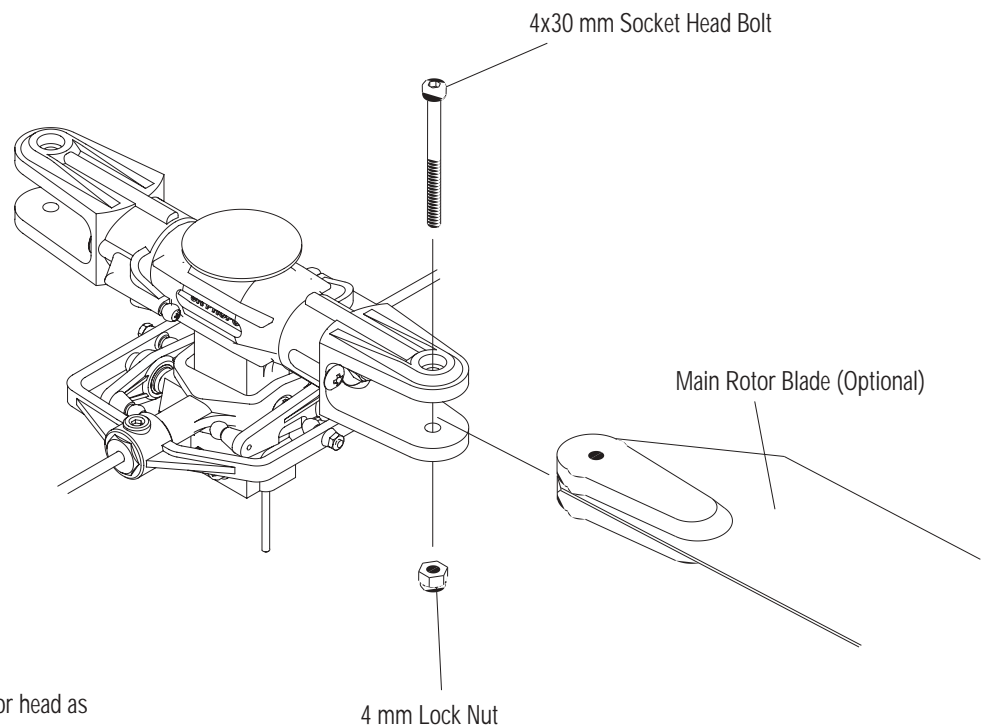
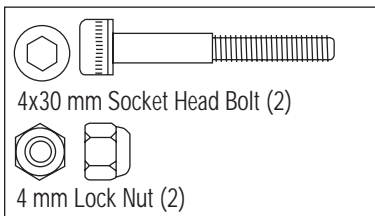

Firmly secure the main rotor blades to the rotor head as shown above. Be certain to note the proper direction of the rotor blades when assembling (clockwise rotation). Main blades should be tightened so they can pivot when moderate pressure is applied. Do not allow the main blades to swing freely within the main blade holders.

For advanced pilots wanting the best 3D performance from the Venture™, 50 3D please perform the following changes as shown.

A. SWASHPLATE MODIFICATION

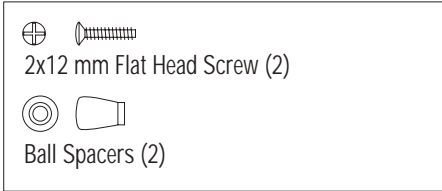

Remove the two short control balls from the upper swashplate ring as shown.

Re-install the control balls using the two ball spacers and two 2x12 mm flat head screws.

This change will allow for increased control to the rotor head for 3D flying.

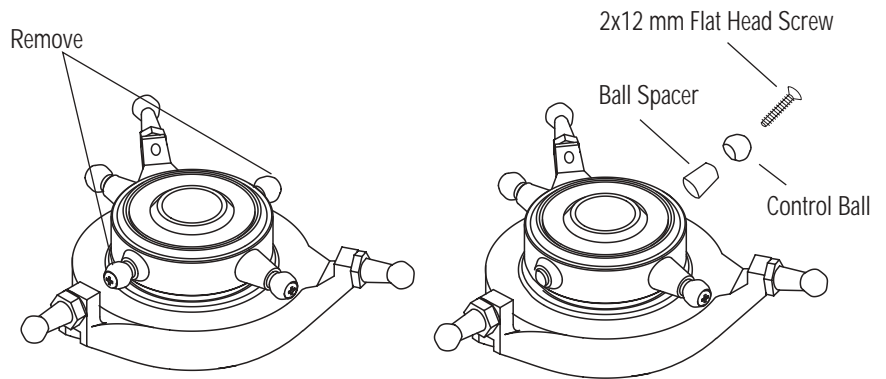

B. CONTROL ROD ADJUSTMENT

To achieve 0° pitch at 1/2 stick for 3D flight, it will be necessary to change the length of the swashplate to seesaw rods to a length of 17 mm as shown.

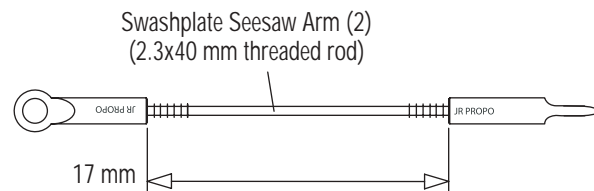

C. 3D FLYBAR/PADDLE INSTALLATION



Remove the current flybar and paddles by removing one paddle and loosening the two 4 mm flybar control arm screws.

Install the special 410 mm 3D flybar and paddles as shown. Check to make sure that the flybar is centered before attaching the paddles.

Thread the 3D paddles onto the flybar through the front hole in the paddles. It is not recommended that the paddles be used in the rear hole, as they will make the control overly aggressive.

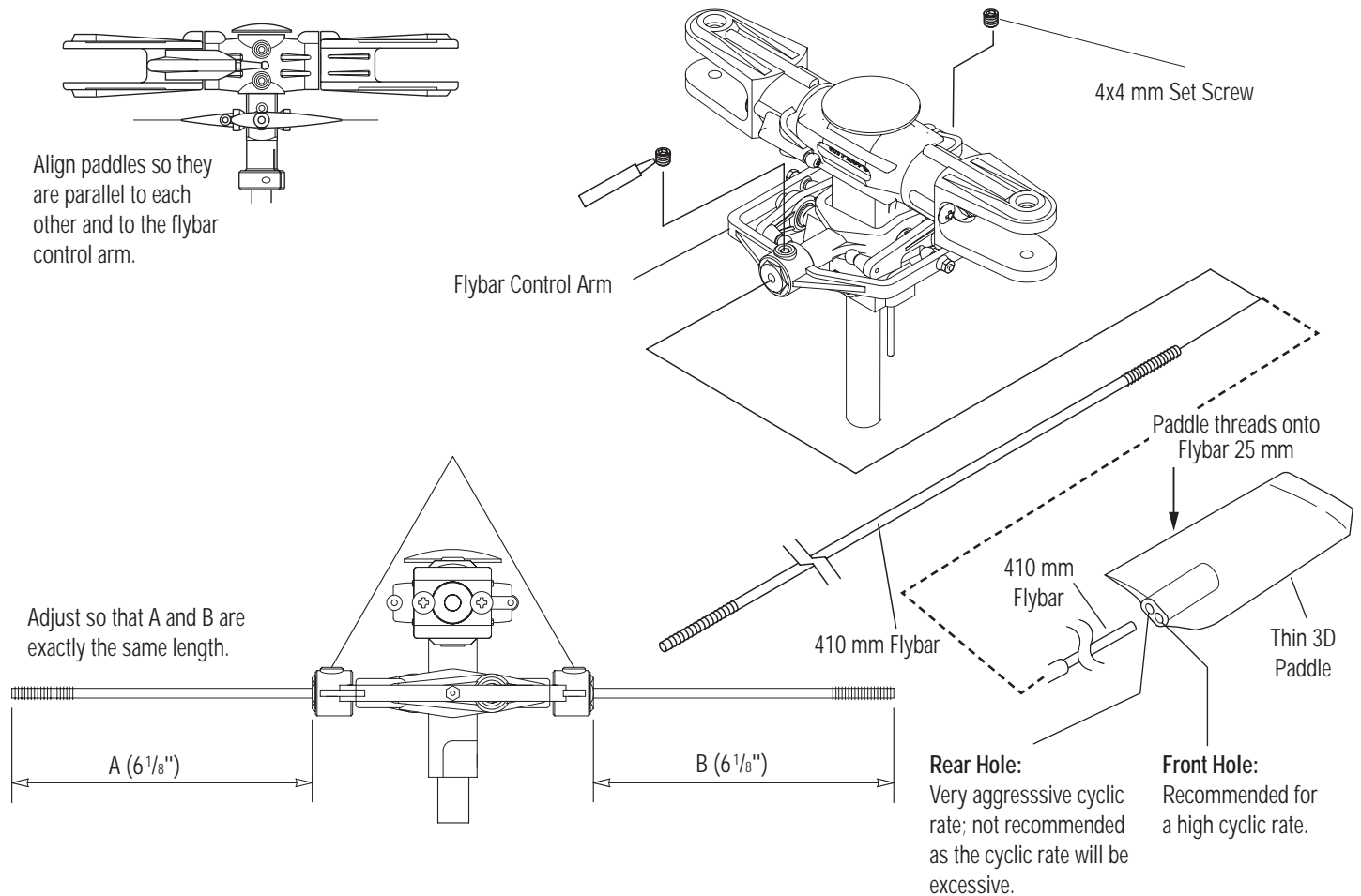

XP662 HELI DATA SHEET VENTURE 50 3D BASIC SETUP

Modulation S-PCM • Z-PCM • PPM (FM)

Model Number _____

Model Name Venture 50 3D Basic Setup

CHANNEL	THR (1)	AIL (2)	ELE (3)	RUD (4)	GER (5)	PITCH (6)
* REVERSE SW	<input type="radio"/> NORM <input type="radio"/> REV	<input type="radio"/> NORM <input type="radio"/> REV	<input type="radio"/> NORM <input type="radio"/> REV	<input type="radio"/> NORM <input type="radio"/> REV	<input type="radio"/> NORM <input type="radio"/> REV	<input type="radio"/> NORM <input type="radio"/> REV
SUB-TRIM	Adjust as needed					
TRAVEL ADJUST (TRV ADJ.)	Refer to the CCPM section of this manual for proper settings					
FAIL-SAFE (S-PCM)						

FAIL-SAFE TIME (Z-PCM)	
------------------------	--

D/R SW	Factory Preset
--------	----------------

GEAR SW	Factory Preset
---------	----------------

THRO HOLD (HLD)	<input type="radio"/> ON <input type="radio"/> OFF	POSITION
		± Adjust for Idle

REVO-MIX (RV)	+ UP (U) - DOWN (D)	Refer to your gyro's instructions for proper settings
HOLD RUDD OFFSET (OFFSET HLD)	±	

STUNT TRIM		ON • OFF
AIL (2) +	ELE (3) +	RUD (4) +
-	-	-
Adjust stunt trim values as needed		

			AIL (AI)	ELEV (EL)
DUAL RATE	POS 0	D/R	90%	90%
		EXP	20%	20%
EXP	POS 1	D/R	100%	100%
		EXP	30%	30%

		L	2	H
THRO CURVE TLN, T2N, THN,	N	0%	50%	100%
TLS, T2S	S	40%	60%	/
PITCH CURVE PLN, P2N, PHN,	N	-2° Pitch	5° Pitch	10° Pitch
PLS, P2S, PHS,	S	-5° Pitch	5° Pitch	10° Pitch
PLH, P2H, PHH	H	-5° Pitch	5° Pitch	13° Pitch

CCPM MIXING		<input type="radio"/> ON <input type="radio"/> OFF
AIL (2) + 70% - 70%	ELE (3) + 70% - 70%	Pitch (6) + 65% - 65%

		CHANNEL MASTER SLAVE	MIX SWITCH	OFFSET	+GAIN	-GAIN
PROG. MIX	A	→	ON • F1 • FO • H			

TRIM OFFSET	
-------------	--

XP662 HELI DATA SHEET VENTURE 50 3D SETUP

Modulation S-PCM • Z-PCM • PPM (FM)

Model Number _____

Model Name Venture 50 3D Setup

CHANNEL	THR (1)	AIL (2)	ELE (3)	RUD (4)	GER (5)	PITCH (6)
* REVERSE SW	<input type="radio"/> NORM • <input type="radio"/> REV	<input type="radio"/> NORM • <input type="radio"/> REV	<input type="radio"/> NORM • <input type="radio"/> REV	<input type="radio"/> NORM • <input type="radio"/> REV	<input type="radio"/> NORM • <input type="radio"/> REV	<input type="radio"/> NORM • <input type="radio"/> REV
SUB-TRIM	Adjust as needed					
TRAVEL ADJUST (TRV ADJ.)	Refer to the CCPM section of this manual for proper settings					
FAIL-SAFE (S-PCM)						

FAIL-SAFE TIME (Z-PCM)	
------------------------	--

D/R SW	Factory Preset
--------	----------------

GEAR SW	Factory Preset
---------	----------------

THRO HOLD (HLD)	<input type="radio"/> ON <input type="radio"/> OFF	POSITION
		± Adjust for Idle

REVO-MIX (RV)	+	UP (U)	Refer to your gyro's instructions for proper settings
	-	DOWN (D)	
HOLD RUDD OFFSET (OFFSET HLD)	±		

STUNT TRIM		ON • OFF
AIL (2)	ELE (3)	RUD (4)
+	+	+
-	-	-
Adjust stunt trim values as needed		

			AIL (AI)	ELEV (EL)
DUAL RATE	POS 0	D/R	90%	90%
		EXP	Adjust as needed	
EXP	POS 1	D/R	100%	100%
		EXP	Adjust as needed	

		L	2	H
THRO CURVE TLN, T2N, THN,	N	0%	50%	100%
TLS, T2S	S	40%	60%	
PITCH CURVE PLN, P2N, PHN,	N	-2° Pitch	<input type="radio"/> 5° Pitch	10° Pitch
PLS, P2S, PHS,	S	-10° Pitch	<input type="radio"/> 0° Pitch	10° Pitch
PLH, P2H, PHH	H	-5° Pitch	<input type="radio"/> 5° Pitch	13° Pitch

CCPM MIXING		<input type="radio"/> ON • OFF
AIL (2)	ELE (3)	Pitch (6)
<input type="radio"/> + 70%	<input type="radio"/> + 70%	<input type="radio"/> + 65%
<input type="radio"/> -	<input type="radio"/> -	<input type="radio"/> -

		CHANNEL MASTER SLAVE	MIX SWITCH	OFFSET	+GAIN	-GAIN
PROG. MIX	A	→	ON • F1 • FO • H			

TRIM OFFSET	
-------------	--

X-378 HELI DATA SHEET VENTURE 50 3D BASIC SETUP

MODEL NO. _____

MODEL NAME Venture 50 3D Basic Setup

MODULATION SPCM · ZPCM · PPM _____

		AILE	ELEV	RUDD	
DUAL-RATE • EXP	0	D/R	90%	90%	90%
		EXP	20%	20%	30%
	1	D/R	100%	100%	100%
		EXP	30%	30%	30%
A.D.T.	NORM				
	S T - 1				
	S T - 2				
	HOLD				

AUTO D/R (POS. 1)	ST1	OFF • ON
	ST2	OFF • ON
	ST2	OFF • ON

INPUT SEL	AUX2	HOLD SW • PIT.TRIM • INH
	GEAR	ACT • INH

	THRO	AILE	ELEV	RUDD	GEAR	PIT	AUX2
REVERSE SW	<input checked="" type="radio"/> NORM • <input type="radio"/> REV	<input checked="" type="radio"/> NORM • <input type="radio"/> REV	<input checked="" type="radio"/> NORM • <input type="radio"/> REV	<input checked="" type="radio"/> NORM • <input type="radio"/> REV	<input checked="" type="radio"/> NORM • <input type="radio"/> REV	<input checked="" type="radio"/> NORM • <input type="radio"/> REV	<input checked="" type="radio"/> NORM • <input type="radio"/> REV
SUB TRIM	ADJUST AS NEEDED						
TRAVEL ADJUST	REFER TO THE CCPM SECTION OF THE MANUAL FOR PROPER SETTINGS						
FAIL SAFE (SPCM)							

		EXP	L	1	2	3	H			
THROTTLE CURVE	N	OFF • ON	0%	%	50%	%	100%	GYRO SENS	0	%
	1	OFF • ON	40%	%	60%	%	100%		1	%
	2	OFF • ON	%	%	%	%	%		NORM	
PITCH CURVE	N	OFF • ON	-2° Pitch	%	5° Pitch	%	10° Pitch		STNT	
	1	OFF • ON	-5° Pitch	%	5° Pitch	%	10° Pitch		HOLD	
	2	OFF • ON	%	%	%	%	%		INVT	
	H	OFF • ON	-5° Pitch	%	5° Pitch	%	13° Pitch	THRO HOLD	<input checked="" type="radio"/> OFF • <input type="radio"/> ON	POS Adjust for Idle

INVERTED	<input checked="" type="radio"/> ON	OFFSET
		%

SWASH MIX	TYPE		1S • 2S • <input checked="" type="radio"/> 3S120 • 3S90
	EXP	GAIN	AILE +70%
	<input checked="" type="radio"/> OFF • <input type="radio"/> ON		ELEV +70%
			PITCH -65%

REVO MIX	NORMAL	UP	%
		DOWN	%
	STUNT	UP	%
		DOWN	%
HOLD RUDD OFFSET		%	
ACC MIX			

Refer to your gyro's instructions for proper settings

PROGRAM MIX	CHANNEL		SW	+POS	-POS	OFFSET
	MIX1	→		%	%	
	MIX2	→		%	%	
	MIX3	→		%	%	

X-378 HELI DATA SHEET VENTURE 50 3D SETUP

MODEL NO. _____

MODEL NAME Venture 50 3D Setup

MODULATION SPCM · ZPCM · PPM _____

		AILE	ELEV	RUDD	
DUAL-RATE • EXP	0	D/R	90%	90%	90%
		ADJUST AS NEEDED			
	1	D/R	100%	100%	100%
		ADJUST AS NEEDED			
A.D.T.	NORM		0	0	0
	S T - 1		1	1	1
	S T - 2		1	1	1
	HOLD		1	1	1

AUTO D/R (POS. 1)	ST1	OFF • <input checked="" type="radio"/> ON
	ST2	OFF • <input checked="" type="radio"/> ON
	ST2	OFF • <input checked="" type="radio"/> ON

INPUT SEL	AUX2	HOLD SW • PIT.TRIM • INH
	GEAR	ACT • INH

	THRO	AILE	ELEV	RUDD	GEAR	PIT	AUX2
REVERSE SW	<input checked="" type="radio"/> NORM • <input type="radio"/> REV	<input checked="" type="radio"/> NORM • <input type="radio"/> REV	<input checked="" type="radio"/> NORM • <input type="radio"/> REV	<input checked="" type="radio"/> NORM • <input type="radio"/> REV	<input checked="" type="radio"/> NORM • <input type="radio"/> REV	<input checked="" type="radio"/> NORM • <input type="radio"/> REV	<input checked="" type="radio"/> NORM • <input type="radio"/> REV
SUB TRIM	ADJUST AS NEEDED						
TRAVEL ADJUST	REFER TO THE CCPM SECTION OF THE MANUAL FOR PROPER SETTINGS						
FAIL SAFE (SPCM)							

	EXP	L	1	2	3	H	
THROTTLE CURVE	N	OFF • <input checked="" type="radio"/> ON	0%	%	50%	%	100%
	1	OFF • <input checked="" type="radio"/> ON	40%	%	60%	%	100%
	2	OFF • <input checked="" type="radio"/> ON	100%	%	60%	%	100%
PITCH CURVE	N	OFF • <input checked="" type="radio"/> ON	-2° Pitch	%	5° Pitch	%	10° Pitch
	1	OFF • <input checked="" type="radio"/> ON	-5° Pitch	%	5° Pitch	%	10° Pitch
	2	OFF • <input checked="" type="radio"/> ON	-10° Pitch	%	0° Pitch	%	10° Pitch
	H	OFF • <input checked="" type="radio"/> ON	-5° Pitch	%	5° Pitch	%	13° Pitch

GYRO SENS	INH • RUDD D/R • <input checked="" type="radio"/> AUTO	0	80%
		1	60%
		NORM	0
		STNT	1
		HOLD	1
		INVT	

THRO HOLD	<input checked="" type="radio"/> OFF • <input type="radio"/> ON	POS Adjust for Idle
--------------	---	------------------------

INVERTED	<input checked="" type="radio"/> OFF • <input type="radio"/> ON	OFFSET %
----------	---	-------------

SWASH MIX	TYPE	1S • 2S • <input checked="" type="radio"/> 6S120 • 3S90
	EXP	AILE +70%
	<input checked="" type="radio"/> OFF • <input type="radio"/> ON	ELEV +70%
	GAIN	PITCH -65%

REVO MIX	NORMAL	UP	%
		DOWN	%
	STUNT	UP	%
		DOWN	%
HOLD RUDD OFFSET		%	
ACC MIX			

Refer to your gyro's instructions for proper settings

PROGRAM MIX	CHANNEL	SW	+POS	-POS	OFFSET
	MIX1	→	%	%	
	MIX2	→	%	%	
	MIX3	→	%	%	

XP8103 HELI DATA SHEET VENTURE 50 3D BASIC SETUP

MODEL NO. _____

MODEL NAME Venture 50 3D Setup

MODULATION SPCM · ZPCM · PPM _____

		AILE	ELEV	RUDD
DUAL-RATE • EXP	0	D/R	90%	90%
		EXP	Adjust as needed	
	1	D/R	100%	100%
		EXP	Adjust as needed	

AUTO D/R (POS. 1)	ST1	INH • ACT
	ST2	INH • ACT
	ST2	INH • ACT

INPUT SEL	AUX2	HOLD SW • PIT.TRIM • INH
	GEAR	ACT • INH

	THRO	AILE	ELEV	RUDD	GEAR	PIT	AUX2	AUX3
REVERSE SW	<u>NORM</u> • REV	NORM • <u>REV</u>	<u>NORM</u> • REV	NORM • <u>REV</u>	<u>NORM</u> • REV	<u>NORM</u> • REV	<u>NORM</u> • REV	<u>NORM</u> • REV
SUB TRIM	Adjust as needed							
TRAVEL ADJUST	Refer to the CCPM section of this manual for proper settings							
FAIL SAFE (SPCM)								

		EXP	L	1	2	3	H
THROTTLE CURVE	N	OFF • ON	0%	30%	50%	70%	100%
	1	OFF • ON	40%	50%	60%	80%	100%
	2	OFF • ON	Optional				
PITCH CURVE	N	OFF • ON	-2° pitch	%	5° pitch	%	10° pitch
	1	OFF • ON	-5° pitch	%	5° pitch	%	10° pitch
	2	OFF • ON	%	%	%	%	%
	H	OFF • ON	-5° pitch	%	5° pitch	%	13° pitch

GYRO SENS	INH • RUDD D/R • <u>AUTO</u>	0	80%
		1	60%
		NORM	0
		STNT	1
		HOLD	1
		INVT	1

Refer to gyro gain section for settings

THRO HOLD	INH • <u>ACT</u>	POS Set for idle
-----------	------------------	---------------------

THRO HOLD	INH • <u>ACT</u>	OFFSET Adjust as needed
-----------	------------------	----------------------------

REVO MIX	NORMAL	UP	%
		DOWN	%
	STUNT	UP	%
		DOWN	%
ACC MIX			%

Refer to your gyro's instructions for proper settings

		CHANNEL	SW	EXP	L	1	2	3	H
PROGRAM MIX	MIX1	→		OFF-ON					
	MIX2	→		OFF-ON					
					+POS	-POS	OFFSET		
	MIX3	→		%	%				

Swash Type	1 Servo Norm 2 Servo 180° 3 Servo 120° 4 Servo 90°			
	Aile	Elev	Pit	
Exp Act • <u>INH</u>	<u>+</u> 70%	<u>+</u> 70%	<u>+</u> 65%	

XP8103 HELI DATA SHEET VENTURE 50 3D SETUP

MODEL NO. _____

MODEL NAME Venture 50 3D Setup

MODULATION SPCM - ZPCM - PPM _____

			AILE	ELEV	RUDD
DUAL-RATE • EXP	0	D/R	90%	90%	90%
		EXP	Adjust as needed		
	1	D/R	100%	100%	100%
		EXP	Adjust as needed		

AUTO D/R (POS. 1)	ST1	INH • ACT
	ST2	INH • ACT
	ST2	INH • ACT

INPUT SEL	AUX2	HOLD SW • PIT.TRIM • INH
	GEAR	ACT • INH

	THRO	AILE	ELEV	RUDD	GEAR	PIT	AUX2	AUX3
REVERSE SW	NORM • REV	NORM • REV	NORM • REV	NORM • REV	NORM • REV	NORM • REV	NORM • REV	NORM • REV
SUB TRIM	Adjust as needed							
TRAVEL ADJUST	Refer to the CCPM section of this manual for proper settings							
FAIL SAFE (SPCM)								

		EXP	L	1	2	3	H
THROTTLE CURVE	N	OFF•ON	0%	30%	50%	70%	100%
	1	OFF•ON	100%	80%	50%	80%	100%
	2	OFF•ON	Optional				
PITCH CURVE	N	OFF•ON	-2° pitch	%	5° pitch	%	10° pitch
	1	OFF•ON	10° pitch	%	0° pitch	%	10° pitch
	2	OFF•ON	%	%	%	%	%
	H	OFF•ON	-5° pitch	%	5° pitch	%	13° pitch

GYRO SENS	INH • RUDD D/R • AUTO	0	80%
		1	60%
		NORM	0
		STNT	1
		HOLD	1
		INVT	1

Refer to your gyro's instructions for proper settings

THRO HOLD	INH • ACT	POS Set for idle
-----------	------------------	---------------------

THRO HOLD	INH • ACT	OFFSET Adjust as needed
-----------	------------------	----------------------------

REVO MIX	NORMAL	UP	%
		DOWN	%
	STUNT	UP	%
		DOWN	%
ACC MIX			%

Refer to revolution mixing section for proper settings

		CHANNEL	SW	EXP	L	1	2	3	H
PROGRAM MIX	MIX1	→		OFF-ON					
	MIX2	→		OFF-ON					
					+POS	-POS	OFFSET		
	MIX3	→		%		%			

Swash Type	1 Servo Norm 2 Servo 180° 3 Servo 120° 4 Servo 90°			
	Aile	Elev	Pit	
Exp Act • INH	+ 70%	+ 70%	+ 65%	

10X HELI DATA SHEET
VENTURE 50 3D SETUP

MODEL NO. (84) _____

MODEL NAME (81) _____

MODULATION (85) SPCM-ZPCM-PPM _____

	THRO	AILE	ELEV	RUDD	GEAR	PITCH	AUX2	AUX3	AUX4	AUX5
REVERSE SW	<input type="radio"/> N	<input type="radio"/> N	<input type="radio"/> N	<input type="radio"/> N	<input type="radio"/> N	<input type="radio"/> N	<input type="radio"/> N	<input type="radio"/> N	<input type="radio"/> N	<input type="radio"/> N
TRAVEL ADJUST (12)	Refer to the CCPM section of this manual for proper settings									
SUB-TRIM (15)	Adjust as needed									
TRIM RATE (83)	%									

			AILE	ELEV	RUDD
D/R EXP (13)	0	D/R	90%	90%	90%
		EXP	Adjust as needed		
		TYPE			
	1	D/R	100%	100%	100%
		EXP	Adjust as needed		
		TYPE			
2	D/R	Optional			
	EXP				
	TYPE				
AUTO D/R (23)	ST-1	INH- <input type="radio"/> ACT	0 · <input type="radio"/> 1 · <input type="radio"/> 2	0 · <input type="radio"/> 1 · <input type="radio"/> 2	0 · <input type="radio"/> 1 · <input type="radio"/> 2
	ST-2	INH- <input type="radio"/> ACT	0 · 1 · 2	0 · 1 · 2	0 · 1 · 2
	ST-3	INH- <input type="radio"/> ACT	0 · 1 · 2	0 · 1 · 2	0 · 1 · 2
	ST-4	INH- <input type="radio"/> ACT	0 · 1 · 2	0 · 1 · 2	0 · 1 · 2
	HOLD	INH- <input type="radio"/> ACT	0 · <input type="radio"/> 1 · <input type="radio"/> 2	0 · <input type="radio"/> 1 · <input type="radio"/> 2	0 · <input type="radio"/> 1 · <input type="radio"/> 2

THROTTLE HOLD (16)	HOLD SW	INH- <input type="radio"/> HOLD GEAR
	POS	Adjust for Idle
	AUTO CUT	<input type="radio"/> INH- <input type="radio"/> ACT
	Delay	1/4 <input type="radio"/> 1/2 <input type="radio"/> 3/4 <input type="radio"/> 1

FUNCTION SELECT (17)	FLIGHT EXTRA	<input type="radio"/> INH- <input type="radio"/> GEAR AILE	
	GEAR SW	<input type="radio"/> INH- <input type="radio"/> GEAR HOLD	
	AUX2 SW	<input type="radio"/> INH- <input type="radio"/> ACT	
	PIT. LEVER	LOW	<input type="radio"/> INH- <input type="radio"/> ACT
		HI	<input type="radio"/> INH- <input type="radio"/> ACT
	ADT STUNT	<input type="radio"/> INH- <input type="radio"/> ACT	

GYRO SENS (44)	INH- <input type="radio"/> AUX 3 <input type="radio"/> AUTO	0	Refer to the Gyro Gain Section of this manual for proper settings				
		1					
		2					
		NR	S1	S2	S3	S4	HD
		0	1				1

		CHANNEL		TRIM	SW	OFFSET	+GAIN								-GAIN		
		MASTER	SLAVE				EXP	L	1	2	3	4	5	6	H		
PROGRAM MIX (51) - (58)	1	INH- <input type="radio"/> ACT	→	OFF- <input type="radio"/> ON	NR-S1-S2-S3-S4 HD-AX2-GER												
	2	INH- <input type="radio"/> ACT	→	OFF- <input type="radio"/> ON	NR-S1-S2-S3-S4 HD-AX2-GER												
	3	INH- <input type="radio"/> ACT	→	OFF- <input type="radio"/> ON	NR-S1-S2-S3-S4 HD-AX2-GER												
	4	INH- <input type="radio"/> ACT	→	OFF- <input type="radio"/> ON	NR-S1-S2-S3-S4 HD-AX2-GER												
	5	INH- <input type="radio"/> ACT	→	OFF- <input type="radio"/> ON	NR-S1-S2-S3-S4 HD-AX2-GER	OFF- <input type="radio"/> ON	IN 0										100
	6	INH- <input type="radio"/> ACT	→	OFF- <input type="radio"/> ON	NR-S1-S2-S3-S4 HD-AX2-GER	OFF- <input type="radio"/> ON	IN 0										100
	7	INH- <input type="radio"/> ACT	→	OFF- <input type="radio"/> ON	NR-S1-S2-S3-S4 HD-AX2-GER	OFF- <input type="radio"/> ON	IN 0										100
	8	INH- <input type="radio"/> ACT	→	OFF- <input type="radio"/> ON	NR-S1-S2-S3-S4 HD-AX2-GER	OFF- <input type="radio"/> ON	IN 0										100

10X HELI DATA SHEET
VENTURE 50 3D INITIAL SETUP CONTINUED

		EXP		L	1	2	3	4	5	6	H	
THRO CURVE (18) TH,TRIM=SLOW HOV.T=CENTER	N	OFF	IN	0							100	
		<input checked="" type="radio"/> ON	OUT	0			50%				100	
			HOV.SEL	---	HOV	HOV	HOV	HOV	HOV	HOV	HOV	---
	1	OFF	IN	0								100
		<input checked="" type="radio"/> ON	OUT	100%			60%					100
	2	OFF	IN	0								100
		<input checked="" type="radio"/> ON	OUT									
	3	OFF	IN	0								100
		<input checked="" type="radio"/> ON	OUT									
	4	OFF	IN	0								100
		<input checked="" type="radio"/> ON	OUT									
PITCH CURVE (68) P,TRIM=CENTER HOV.P=CENTER	N	OFF	IN	0							100	
		<input checked="" type="radio"/> ON	OUT	-2°Pitch			5°Pitch				10°Pitch	
			HOV.SEL	---	HOV	HOV	HOV	HOV	HOV	HOV	HOV	---
	1	OFF	IN	0								100
		<input checked="" type="radio"/> ON	OUT	-10°Pitch			0°Pitch					10°Pitch
	2	OFF	IN	0								100
		<input checked="" type="radio"/> ON	OUT									
	3	OFF	IN	0								100
		<input checked="" type="radio"/> ON	OUT									
	4	OFF	IN	0								100
		<input checked="" type="radio"/> ON	OUT									
HOLD	OFF	IN	0								100	
	<input checked="" type="radio"/> ON	OUT	-5°Pitch			5°Pitch					13°Pitch	

TAIL ROTOR CURVE (47)	N	NOR	IN	L	1	2	3	4	5	6	H						
		ORG	OUT														
1	NOR	IN	0	Refer to your gyro's instruction manual for proper settings								100					
	ORG	OUT															
2	NOR	IN	0														100
	ORG	OUT															
3	NOR	IN	0														100
	ORG	OUT															
4	NOR	IN	0														100
	ORG	OUT															
MIX RATE		1/1 · 1/2 · 1/4 · 1/10															

TRIM OFFSET (82)	HV.T	HV.P	LO.P	HI.P

Rudder→Throttle 4→1 MIX (41)	R		%
	L		%
MODE SELECTION	NR · <input checked="" type="radio"/> S1 · S2 · S3 · S4 · AX2		

FAIL-SAFE (77)	Z	MODE	HOLD · 1.0s · 0.5s · 0.25s
		MEMORY	
	S	MEMORY	

Aileron→Throttle 2→1 MIX (41)	R		%
	L		%
MODE SELECTION	NR · <input checked="" type="radio"/> S1 · S2 · S3 · S4 · AX2		

SWASHPLATE MIXING TYPE (65)	1 SERVO · 3SERVO - 120°CCPM · 3SERVO - 140°CCPM			
	1 SERVO	ELE → AIL	D	%
			U	%
	AIL → ELE	L	%	
R		%		
	SWITCH	NR · S1 · S2 · S3 · S4 · HD		
3 SERVO 120° CCPM	AIL	+70%	ELE	+70% PIT -65%
3 SERVO 140° CCPM	AIL	%	ELE	% PIT %

Elevator→Throttle 3→1 MIX (41)	U		%
	D		%
MODE SELECTION	NR · <input checked="" type="radio"/> S1 · S2 · S3 · S4 · AX2		

Now that the radio system is completely installed into the helicopter, it is necessary to check and adjust the following:

1. Servo Direction (Servo Reversing)

Check to insure that all servos have been set to the correct direction as shown in programming section, pages 20-22.

2. Dual Rates

It is suggested that for initial flights the Dual Rate function values be set as follows:

- 0 Position (low rate): 90%
- 1 Position (high rate): 100%

3. Exponential Settings

It is suggested that the exponential rate settings remain in the 0 value position until the initial test flights. After initial flights, adjust the exponential values to achieve the desired control feel.

4. Sub-Trim Settings

It is suggested that the correct neutral settings be achieved without the use of the sub-trim feature. If sub-trim is used for final flight adjustments, it is suggested that the sub-trim values not exceed 20. If the sub-trim values are greater, readjust the control linkages and reset the sub-trims to 0.

5. Pitch/Throttle Curve Adjustment

It is very important that the throttle and pitch curves are adjusted properly to achieve the best performance from your helicopter. When properly adjusted, the main rotor head rpm should remain consistent throughout all maneuvers and throttle stick positions. A constant rpm will also help to improve the effectiveness and accuracy of the tail rotor and gyro systems.

A. Pitch Curve Adjustment

It will now be necessary to adjust the main rotor blade pitch to match the settings shown in the chart. A main rotor blade pitch gauge (sold separately) will be necessary for this procedure. Prior to setting the main rotor blade pitch, it will be necessary to first set the required blade pitch at 1/2 (center) stick. Turn the system on and set the collective pitch stick to the center position as in previous steps. If all linkages are properly adjusted, the swashplate/rotor head system should appear as shown in the diagram below. Please note that at the center pitch position, the seesaw mixing arms located on the rotor head are parallel (level) to the seesaw shaft/flybar assembly.

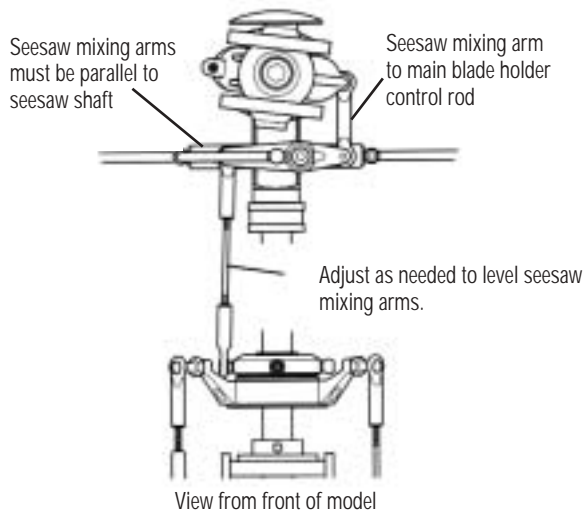

Pitch Range Settings

Flight Mode	Application	Low Pitch (Low Stick)	Hovering Pitch (Half Stick)	High Pitch (High Stick)
N	Hovering	-2°	5°	10°
1	Stunt & Aerobatic Flight	-5°	5°	10°
2	3D Flight	-10°	0°	10°
H	AutoRotation	-5°	5°	13°

Pitch Curve Settings

Hovering (Linear Curve)

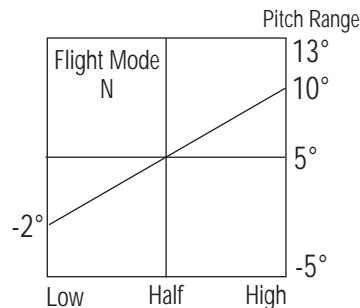

Stunt & Aerobatic Flight

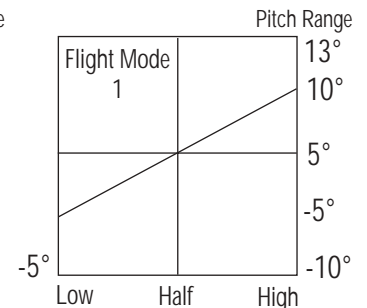

3D Flight

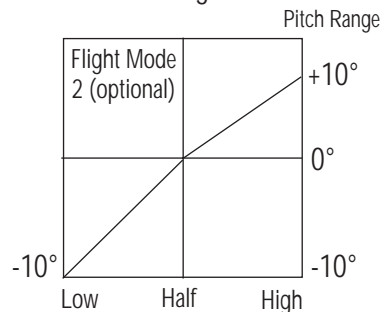

Autoration

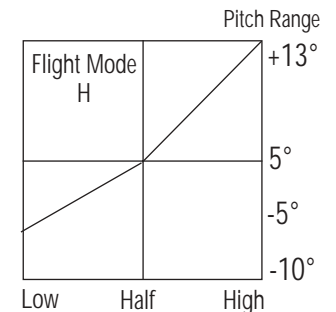

Venture™ 50 Standard Flight

Once the position of the seesaw mixing arms have been established, attach a main rotor pitch gauge (sold separately) to one rotor blade and check the current pitch setting. The current pitch should be approximately +5 at center stick. If the pitch is slightly less or more, this can be adjusted later through the radio's Pitch Curve function. Attach the pitch gauge to the second main rotor blade and match the pitch at this time.

Venture 50 3D Flight

Once the position of the seesaw mixing arms has been established, attach a main rotor pitch gauge (sold separately) to one rotor blade and check the current pitch setting. Adjust the pitch to the desired setting (0° pitch at center stick) by adjusting the seesaw mixing arm to the main blade holder control rods as shown in Step 4-5. Attach the pitch gauge to the second main rotor blade and match the pitch at this time.

It will now be necessary to establish the maximum pitch value required for your application prior to adjustment. For example, if you are a beginning pilot, then your maximum negative pitch will be -5, and your maximum positive pitch will be +10. The maximum pitch range that you will require will be 15°. If you are a 3D pilot flying the Venture, then your maximum negative pitch will be -10, and your maximum positive pitch will be +10 (+13 for autorotations). The maximum pitch range that you will require will be 23°.

The maximum pitch range mentioned above must be established through the use of the pitch travel value in the CCPM function. Do not try to establish the maximum pitch curve values through adjustment of the Travel Adjustment function, as this will alter the pitch-to-aileron and pitch-to-elevator travel values established in Steps 3-7 and 3-8. Please refer to the CCPM activation section, pages 20-22, for information on how to access the CCPM function.

Once the CCPM function has been activated, set the maximum positive pitch settings as mentioned above. Since the CCPM function does not allow for independent travel settings for positive and negative pitch, it will be necessary to establish the maximum positive pitch, since this is generally the largest degree of pitch in the pitch range. Once the maximum positive pitch range is set, the maximum negative Pitch range can be reduced as needed through the Pitch Curve function.

Set the main rotor pitch gauge to the desired maximum pitch setting, then increase or decrease the CCPM pitch travel (labeled Pitch or Ch6) as needed until this pitch setting is achieved.

B. Throttle Curve Settings

Below are several examples of possible throttle curves during various flight conditions. Since throttle curves can vary greatly due to engine and muffler combinations, it will be necessary to fine tune and adjust these values during test flights to achieve a constant main rotor rpm.

Hovering (Linear Curve)

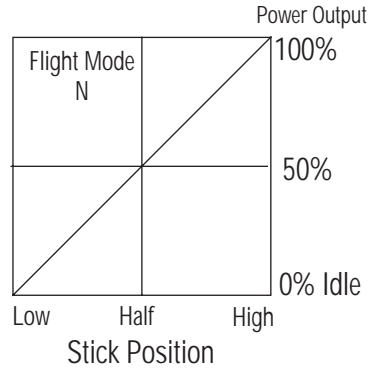

Stunt & Aerobatic Flight

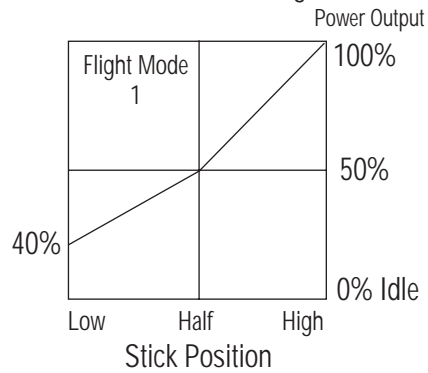

3D Flight (Optional)

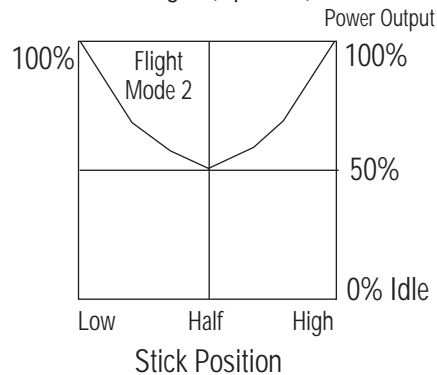

XP652/XP662

MIX [CP6]

-65

Increase or decrease the value as needed.

X-378

+70

Increase or decrease the value as needed.

PCM 10 Series

[SWASH] [ENTER]

TYPE] 3SERVOS(120°)

EXP	AILE	ELEV	PITCH
+70	+70	+65	-65

Increase or decrease the value as needed.

XP8103

[SWASH MIX]

3servos

AILE	+70%
ELEV	+70%
→ PIT.	-65%

Increase or decrease the value as needed.

Once this procedure has been completed, the positive and negative pitch settings for each flight mode can be adjusted through the radio's Pitch Curve function. Please refer to your radio's instruction manual for more information.

It will also be necessary to set the correct idle speed of the engine when the Throttle Hold function is activated. This idle value is located within the Throttle Hold function. This will allow the engine to remain at idle when practicing autorotations.

6. Gyro Gain Adjustment (Dual Remote Gain Gyros only)

It will be necessary to adjust the “gain” or compensation of the gyro to create the correct amount of “holding power” necessary for a solid neutral tail rotor. The intent of the gyro is to compensate for abrupt movements, or wind direction changes.

For hovering, it is recommended that you start with the gyro gain at approximately 80° and continue to increase slightly until the tail of the helicopter “hunts,” then reduce the value slightly.

This same adjustment will also be necessary to achieve proper forward flight. Generally, the gyro gain for forward flight will be approximately 10%–20% less than that of the established hover gain due to aerodynamic forces present in forward flight. We have recommended a 60% value as a good starting position.

7. Verifying Gyro Direction

It will also be necessary to confirm the direction the gyro compensates when the body of the helicopter is rotated.

To do this, turn the radio system on and suspend the helicopter by the main rotor head. Next, move the rudder stick to the right and watch the direction that the tail rotor servo arm travels. Now while watching the tail rotor servo arm, rotate the body of the helicopter counterclockwise. The servo arm should move in the same direction as when the rudder stick was moved to the left. If the arm moves in the opposite direction, reverse the gyro and re-test.

PCM 10 Series Radio with G460T, G550T, and G5000T Gyros

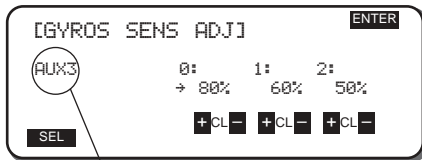

Press *SEL* to select AUX3 or AUTO GAIN function.

XP8103 with G460T, G550T, and G5000T Gyros

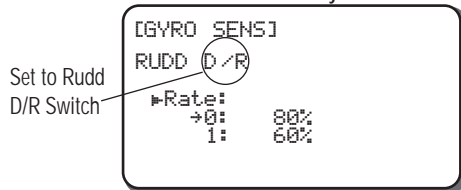

XP652 with G460T, G550T, and G5000T Gyros

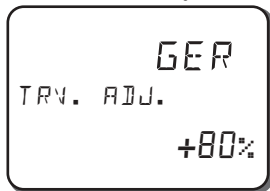

XP652 with G460T, G550T, and G5000T Gyros

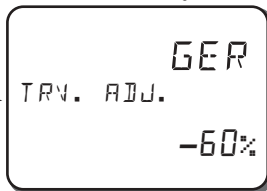

Change switch Position

Please refer to your radio's instructions for more information.

FINAL PREFLIGHT CHECK

Once all assemblies have been completed, please review the following suggestions before attempting initial flights.

- Review the instruction book and confirm that all assembly steps have been completed thoroughly.
- Verify that the tail rotor assembly rotates in the correct direction (see the diagram below).
- Verify that the gyro is operational and compensating in the correct direction (detailed in Step 8, page 49).

- Insure that all servos are operating smoothly and in the correct direction. Also verify that there is no binding in the control rods and that each servo horn is secured with a servo horn mounting screw.
- Make sure that both the transmitter and receiver have been fully charged (refer to your radio system instructions for proper charging procedures).
- Insure that the throttle is working properly and in the correct direction.

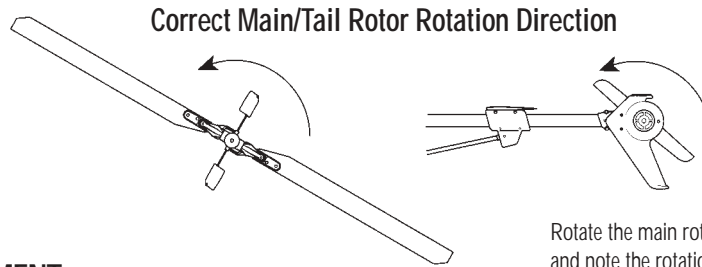

BLADE TRACKING ADJUSTMENT

Blade tracking is an adjustment to the main rotor blade pitch that must be accomplished during the initial test flights. Although the blade pitch angle in each blade may appear equal, it is still possible for a set of main rotor blades to run "out of track," making adjustment necessary. Main rotor blades that are out of track with one another can cause vibration, instability, and a loss of power due to additional drag.

On the initial flight, it will be necessary to increase the blade speed to just before lift-off rpm and view the rotor disc at eye level from a safe distance (approximately 15 to 20 feet).

Note which blade is running low (by colored tracking tape) and increase the pitch of the low blade one turn of the ball link at a time until each blade runs in track (on the same plane).

Please refer to the diagrams below to identify the different tracking situations, as well as several methods to mark each rotor blade for tracking identification.

BLADE TRACKING IDENTIFICATION

Out of Track

Incorrect



In Track

Correct

Adjustment is **not** necessary

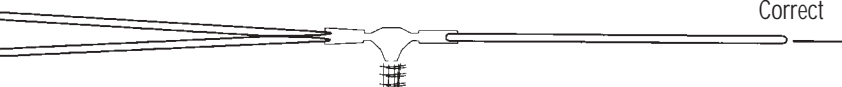

Caution: Be sure to maintain a safe distance from the helicopter (15 to 20 feet) when tracking main rotor blades.



Blade Labeling for Tracking Purposes

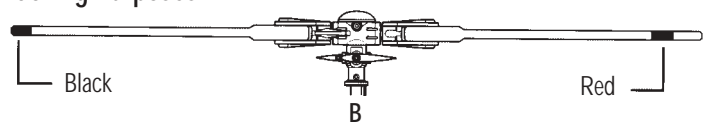
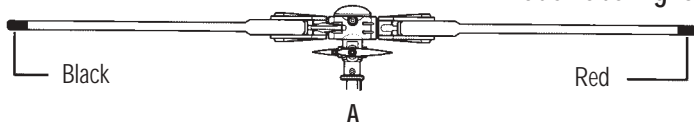

- A: Use two different blade tracking tape colors (e.g., black and red) at the tip of each main rotor blade.
- B: Use the same color blade tracking tape located at different positions on each rotor blade.

Note: Adding additional blade tracking tape to the rotor blades at this stage will make it necessary to re-static balance the main rotor blades.

Flight Training

Flight Simulators

A model helicopter simulator is *highly recommended* and is an excellent training aid. Simulators like the CSM V10 will help you learn the orientation and inputs needed to fly a model helicopter, without the risk of damaging your model to learn these same reactions. In general, most beginning pilots find that using an RC simulator prior to their first actual flights with their model increase the speed in which they learn, and also decrease the number of crashes associated with learning to fly. Even the most experienced Heli pilots continue to practice with a flight simulator to learn new maneuvers and stick inputs prior to trying these maneuvers with their actual models.

Training Gear

Before you commence, it is also *highly recommended* that you first purchase and install helicopter flight training gear to your Venture to prevent accidental prior to tracking the blades, or attempting to fly the model.

Experienced Help

It is also *highly recommended* if possible that you seek help from an experienced RC helicopter pilot prior to your first flights. Contact your local hobby shop for more information on clubs and pilots in your area.

Where to Fly

It is recommended that for your first flights, you locate a large smooth parking lot or paved surface that is in a private setting. The training gear will allow the model to slide smoothly on a flat hard surface, which will reduce the risk of tipovers while learning. A smooth grass surface will also work if it is not possible to locate a large parking lot, however the training gear will have a tendency to catch in the grass which increases the possibility of a tip over.

When to Fly

For your first flights, it is recommended that you chose a day with calm or no wind as the model will be much easier to control without the additional wind factor. Generally, you will want to pick a day where the wind is below 5 mph if possible for the best results. Please also note that the model should always be positioned nose into the wind for the best results.

Basic Hover Training Practices

Once you have properly tracked the main rotor blades and have tuned the engine as needed, it is now time to move on to the initial flight training practices listed below.

Ground Skating

The first step towards learning to fly is ground skating. The model should be positioned nose into the wind, and the pilots should be located approximately 15-20 feet behind the model, and slightly to the left or right. The tail of the model should always face towards the pilot during these initial flight practices. To start ground skating, simply increase the throttle slowly until the model starts to become light in the training skids. Next, move the cyclic stick forward slightly; the model should slide forward. Begin to skate the model slowly to the left, right, forward and backwards gently until you become familiar with the stick inputs. Once you have become comfortable with this, you can also practice rotating the model to the left and right using the rudder stick. Be careful when doing this; if the model rotates the nose towards you, the cyclic controls will be reversed.

Short Stationary Hovering

Once you have become comfortable with ground skating, your next step is to try to perform a short stationary hover. To do this, increase the throttle slowly until the model starts to lift from the ground. When the model is 1 foot from the ground, gently reduce the throttle so that the model will settle back down gently. Continue this procedure, and try to increase the time that the model remains airborne. It is important that you keep the model within 3 feet of the ground while performing this exercise, as this will prevent an accidental tip over.

Long Stationary Hovering

Once you have become comfortable with the short stationary hover, the next step is to try to increase the length of time that you are able to keep the model in stationary hover. Continue to practice this exercise until you are able to keep the model in a stationary hover for a full tank of fuel.

Traveling Hover

Once you have become comfortable with the long stationary hover, the next step is to try to perform a traveling hover. To do this, lift the model into a stationary hover approximately 1 foot from the ground. Next, move the cyclic stick forward gently, the model will start moving forward. Once the model has traveled 10-15 feet, gently pull back on the cyclic stick until the model returns to stationary hover. Next, gently move the cyclic stick backwards until the model returns to its original position in stationary hover. Repeat this exercise for left and right cyclic as well.

Once you have completed these exercises, you are well on your way to learning to Hover. Please seek advice from an experienced heli pilot in your area on flight progression from this stage forward.

Engine

After each day of flying, fully drain the fuel tank. Then, start the engine and let it idle until the engine and the fuel line are completely burned off. It is also suggested that an after-run oil be used to prevent premature engine corrosion.

Tail Rotor Belt

Periodically check the tension on the tail drive belt (as shown in Step 1-2, page 8) to insure that it has sufficient tension for proper engagement. It is especially important to check this after initial test flights.

Check All Nuts and Bolts

A helicopter is subject to high vibration during flight. It is important to check that all screws, nuts, and bolts are properly secured after each day of flying. It is also suggested that you perform a "quick" inspection between each initial test flight for approximately the first 6–10 flights.

Check Ball Link Wear

Check to insure that all universal links fit freely but securely to the control balls. If there is excessive play noted, replace the universal link in question.

Battery Maintenance

Check to insure that your batteries are properly mounted and charged. The most frequent cause of crashes (aside from pilot error) is battery failure or disconnection. Be certain that your batteries are fully charged and limit your flight time to 3 or 4 flights between charging. If more flight time is required, purchase a reliable quick field charger.

Cleaning

At the end of each flight or flying session, wipe down your helicopter with a clean towel or rag. This is also a good time to inspect all parts for tightness or fatigue. A clean, well-maintained helicopter will provide you with many hours of trouble-free flight.

PROBLEM	CAUSE	CURE
Helicopter vibrates excessively	<ul style="list-style-type: none"> a. Rotor blades out of balance b. Flybar/paddles not centered c. Engine running roughly d. Excessive clutch run out 	<ul style="list-style-type: none"> Re-balance rotor blades Re-center flybar on rotor head Re-adjust engine lean/rich settings Re-align clutch assembly
Engine runs inconsistent	<ul style="list-style-type: none"> a. Incorrect fuel mixture b. Fuel line problem c. Glow plug damaged 	<ul style="list-style-type: none"> Re-adjust engine settings Check/replace lines (including inside the tank) Replace glow plug
Main rotor blades do not track	<ul style="list-style-type: none"> a. Blade pitch not equal b. Blades warped or twisted 	<ul style="list-style-type: none"> Re-set blade pitch w/ gauge and retest Check and replace as needed
Model "wobbles" in hover	<ul style="list-style-type: none"> a. Rotor rpm too low 	<ul style="list-style-type: none"> Increase throttle at hover or decrease pitch
Clutch grabs when at idle	<ul style="list-style-type: none"> a. Engine rpm too high b. Engine/clutch mis-aligned 	<ul style="list-style-type: none"> Reduce trim value/engine rpm Re-align and retest
Model will not lift off the ground	<ul style="list-style-type: none"> a. Engine too rich b. Blade pitch incorrect c. Throttle curve incorrect 	<ul style="list-style-type: none"> Lean needle valve settings Re-check with pitch gauge Re-check throttle curve settings
Model rotates uncontrollably	<ul style="list-style-type: none"> a. Gyro direction reversed b. Tail servo reversed c. Gyro gain too low d. Main rotor rpm too low 	<ul style="list-style-type: none"> Re-check gyro direction and retry Re-check servo direction and retry Increase gyro gain and retry Increase throttle or decrease pitch
Model constantly drifts in same direction	<ul style="list-style-type: none"> a. Linkage out of adjustment b. Servo centering not correct c. Trim levers not centered 	<ul style="list-style-type: none"> Re-check linkages per manual Re-check servo neutral and reset Check TX trim lever position

For additional questions, please contact:
Venture Help Line: 217-355-9511
9a.m.–5p.m. Mon–Fri CST
E-mail: venturehelp@horizonhobby.com

The following parts included in your kit are preassembled. When maintenance or repair is necessary, please refer to these sections for disassembly or reassembly procedures.

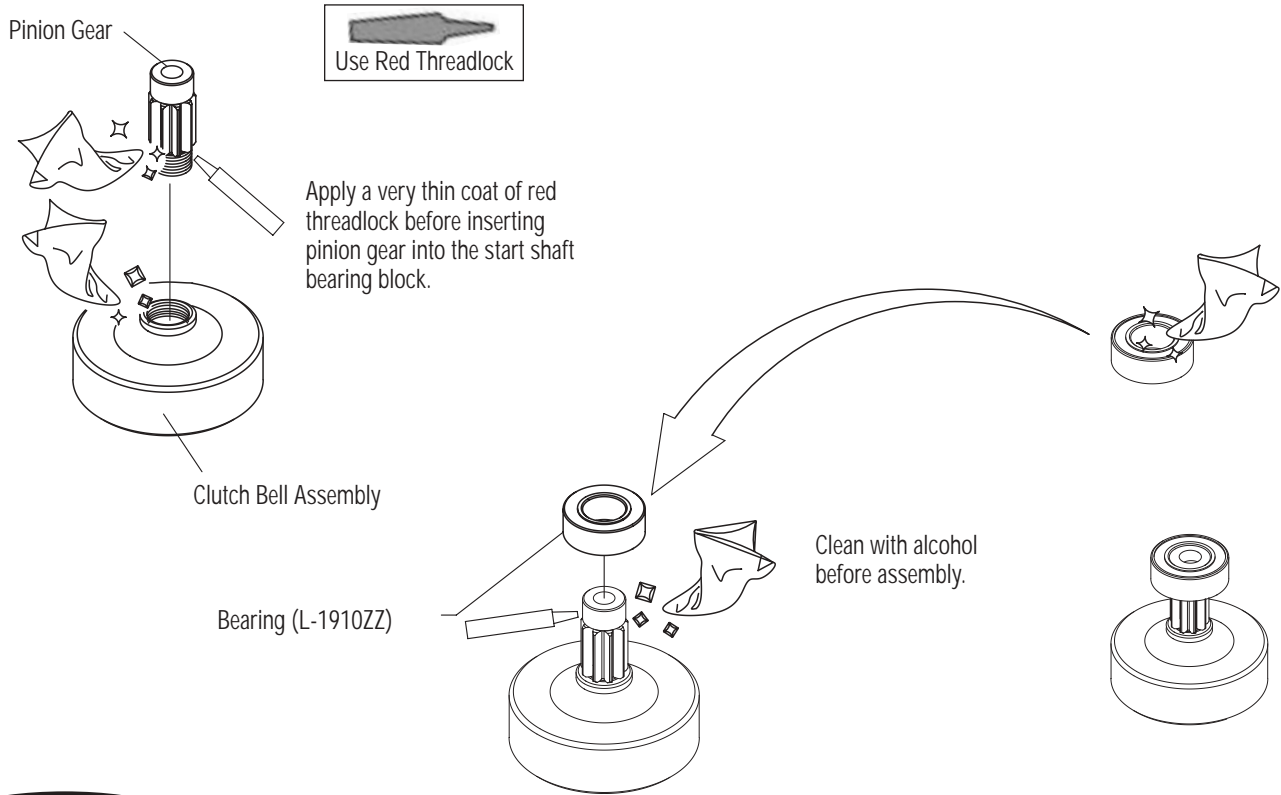

1-1

CLUTCH BELL ASSEMBLY



1-2

TAIL DRIVE PINION/BEARING ASSEMBLY

-  3x6 mm Socket Head Bolt (1)
-  3 mm Flat Washer (1)

Use Red Threadlock

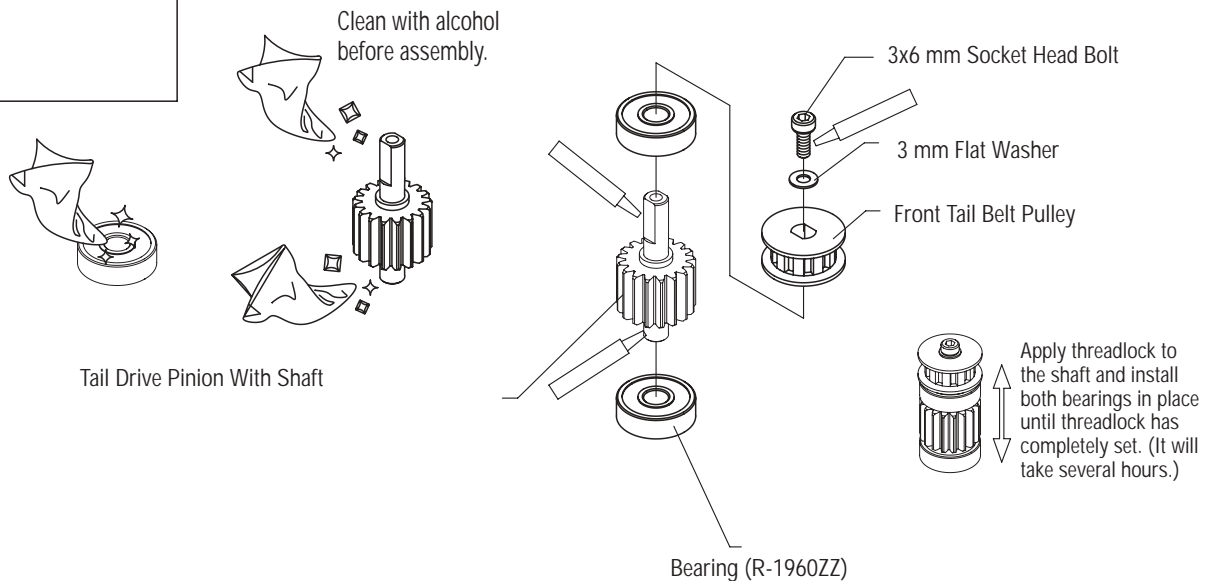

1-3

ELEVATOR ARM ASSEMBLY

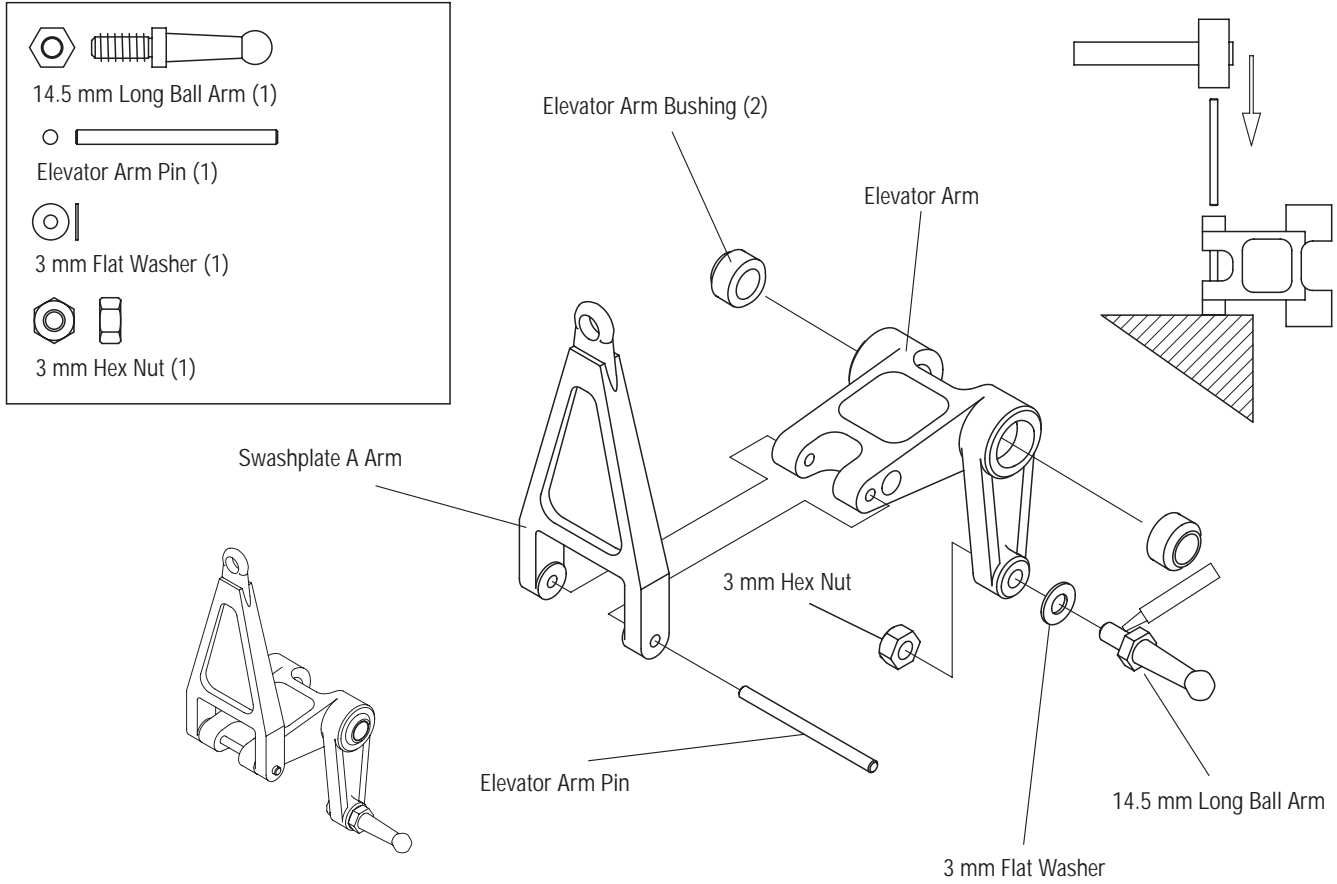

1-4

FUEL TANK ASSEMBLY

Trim to a length of 45 mm before installation.

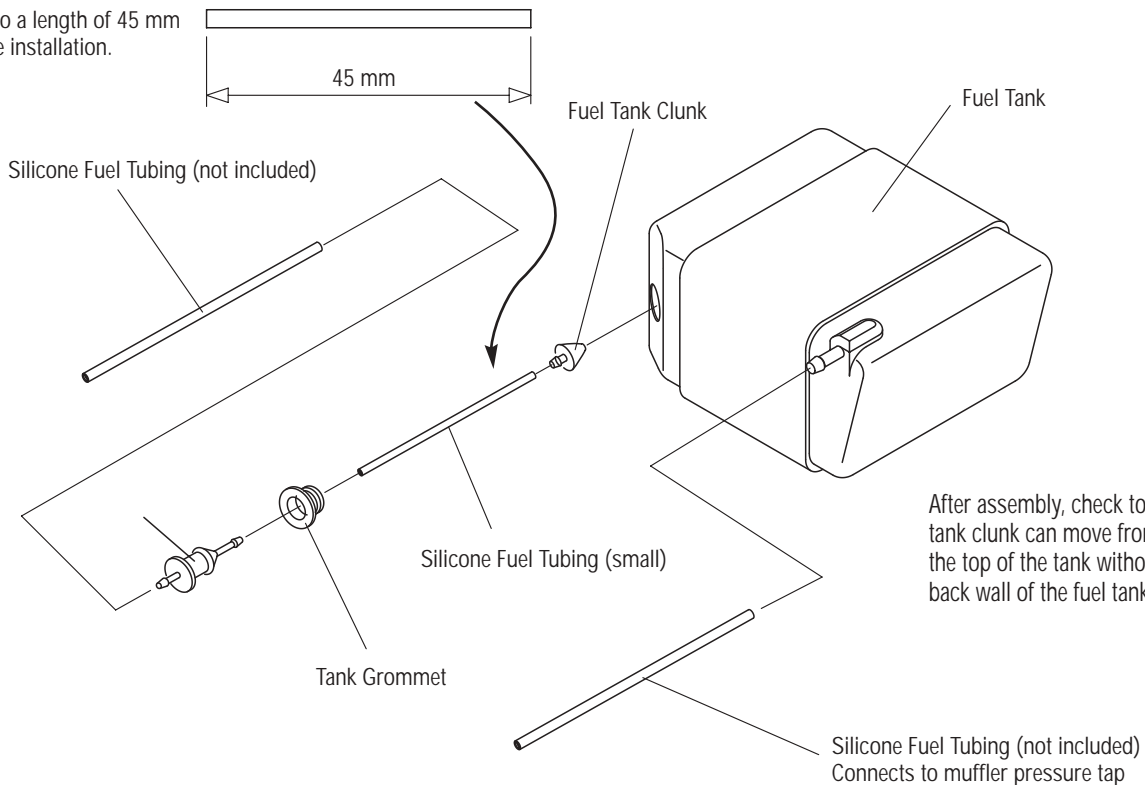

2-1

MAIN FRAME SECTION ASSEMBLY

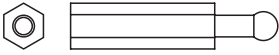

Body Mounting Post, 20 mm (4)



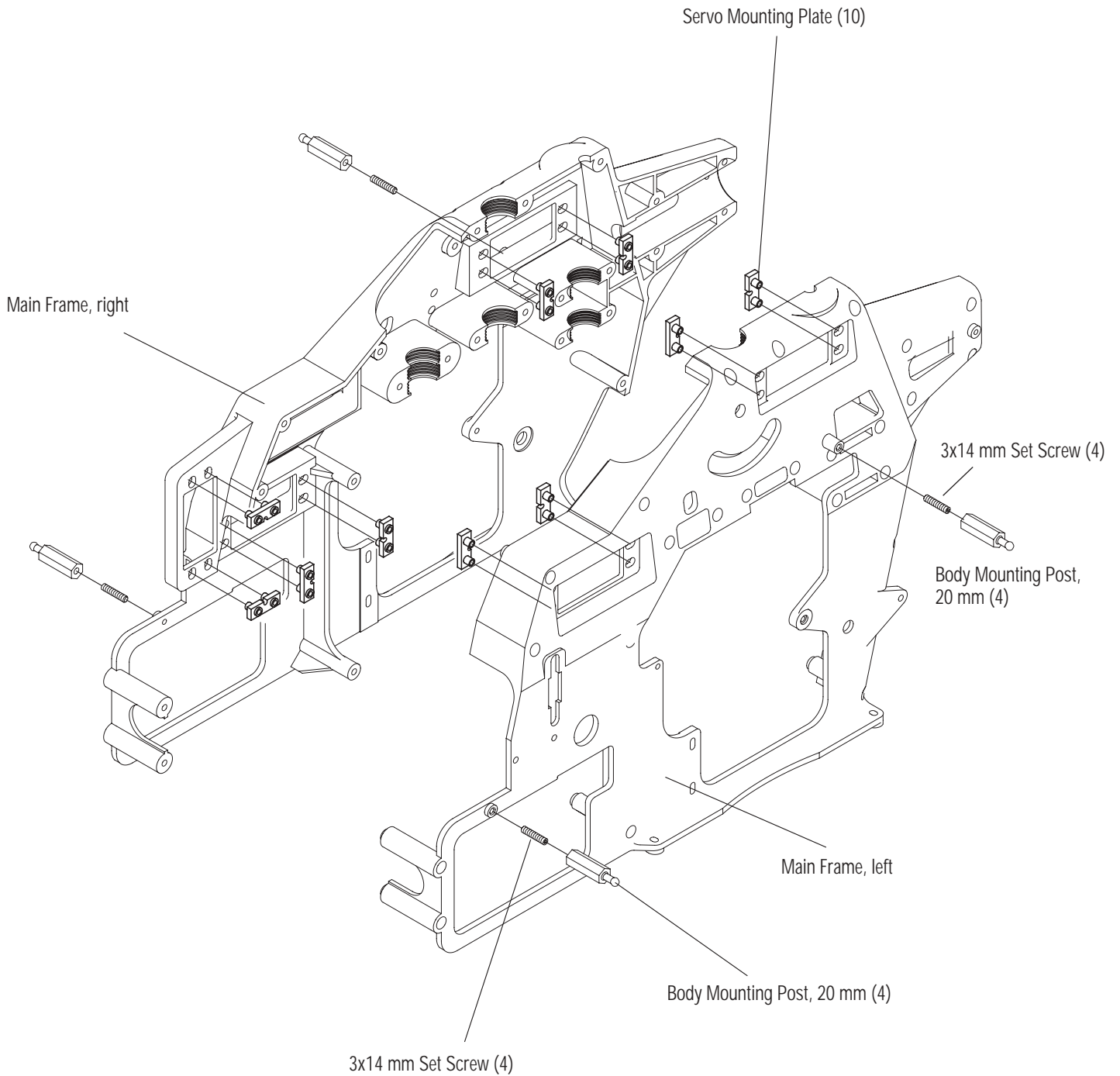

3x14 mm Set Screw (4)

Install the servo mounting plates as shown.

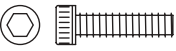

2-2

MAIN FRAME CLUTCH/TAIL PINION/ELEVATOR/FUEL TANK INSTALLATION

-  3x8 mm Socket Head Bolt (2)
-  3x15 mm Socket Head Bolt (20)
-  3 mm Lock Nut (20)
-  Elevator Arm Bushing 32 mm (1)

Use Blue Threadlock

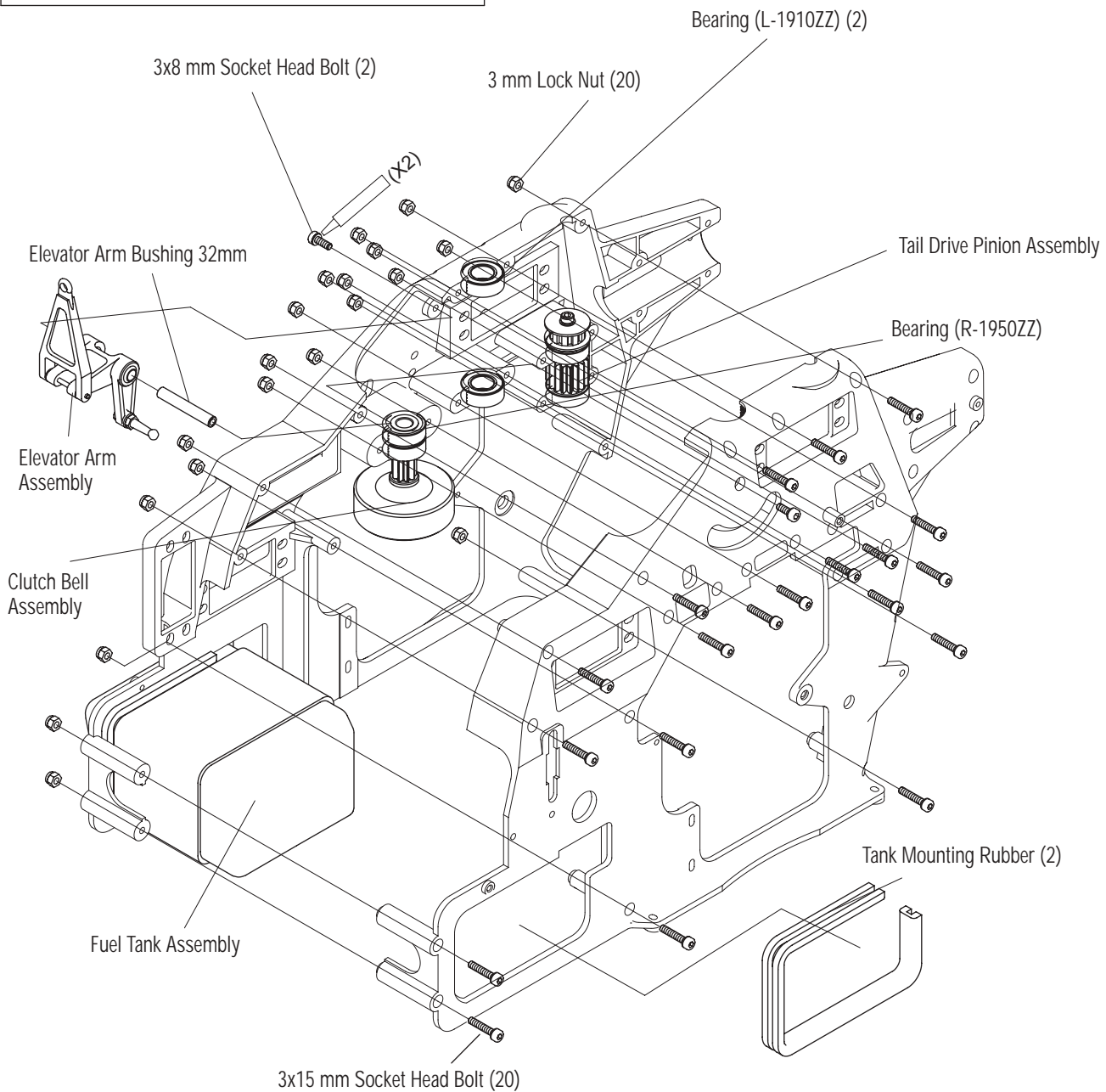

2-3

FRONT RADIO BED/COOLING FAN SHROUD INSTALLATION



3x10 mm Socket Head Bolt (4)



2.6x10 mm Self-Tapping Screw (4)

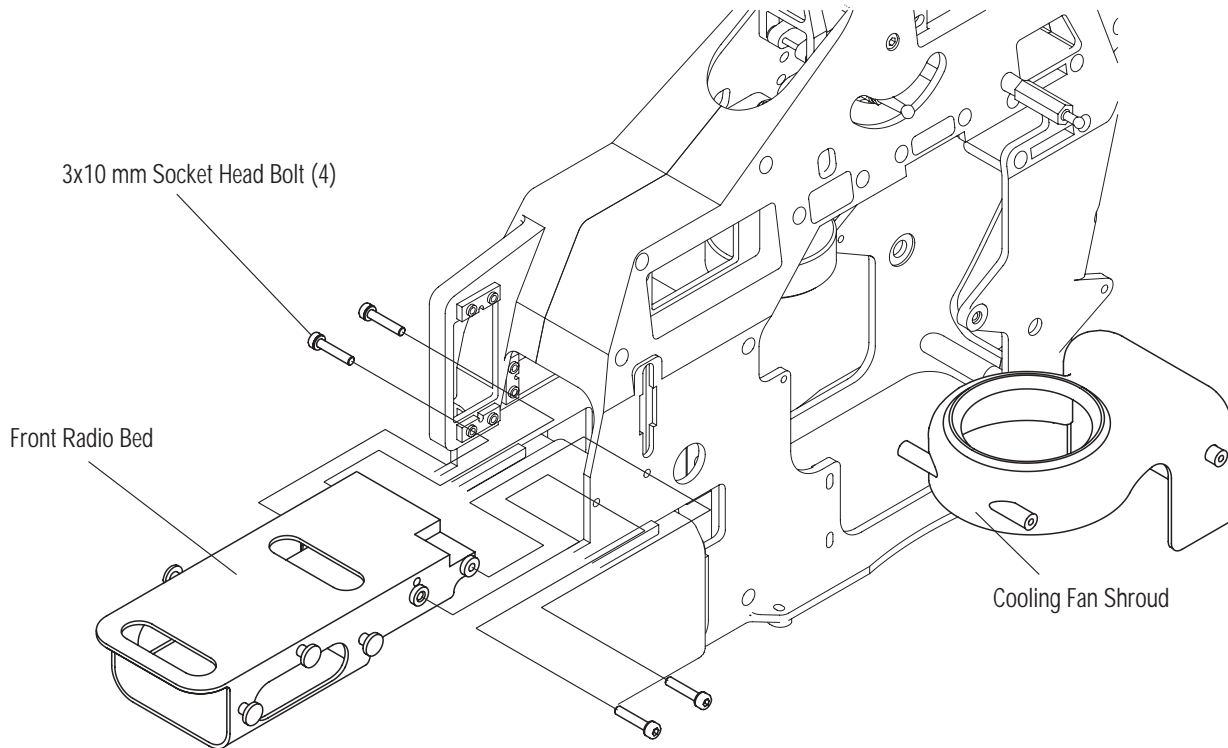

2.6x10 mm Self-Tapping Screw (4)

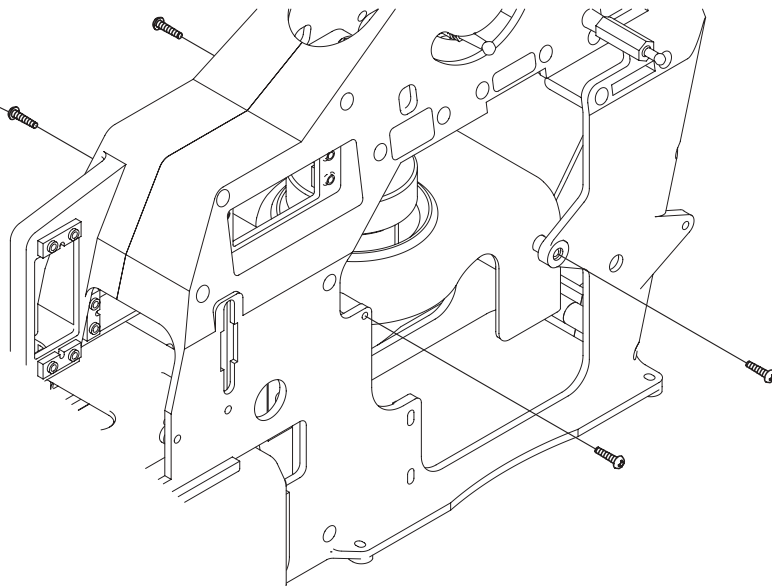

3-1

MAIN DRIVE GEAR/AUTOROTATION/LSD CLUTCH ASSEMBLY



4x4 mm Set Screw (2)



3x35 mm Socket Head Bolt (1)



3mm Lock Nut (1)

Secure the autorotation hub to the main rotor shaft using the 3x22 mm socket head bolt. Next, slide the main shaft collar onto the main rotor shaft. While pulling upward on the main rotor shaft, secure the main shaft collar to the main rotor shaft using the four 4x4 mm set screws.



Apply upwards pressure to the LSD clutch during attachment to set the desired level of friction/tail drive.



Use Blue Threadlock

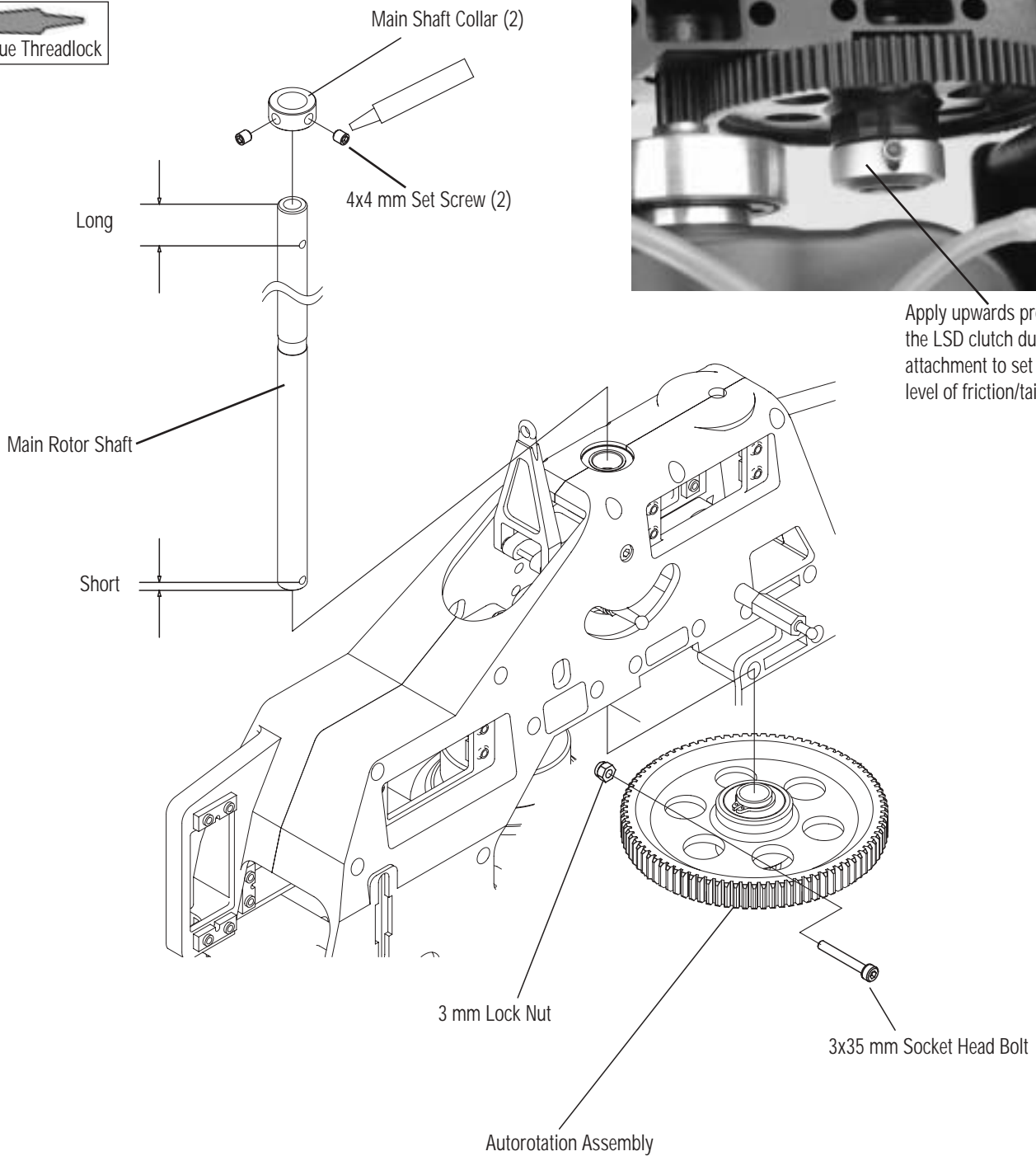

3-2

LANDING GEAR ASSEMBLY INSTALLATION

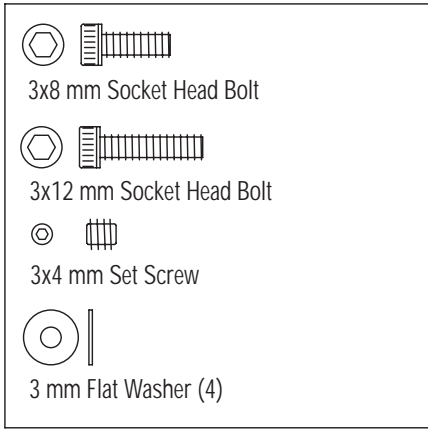



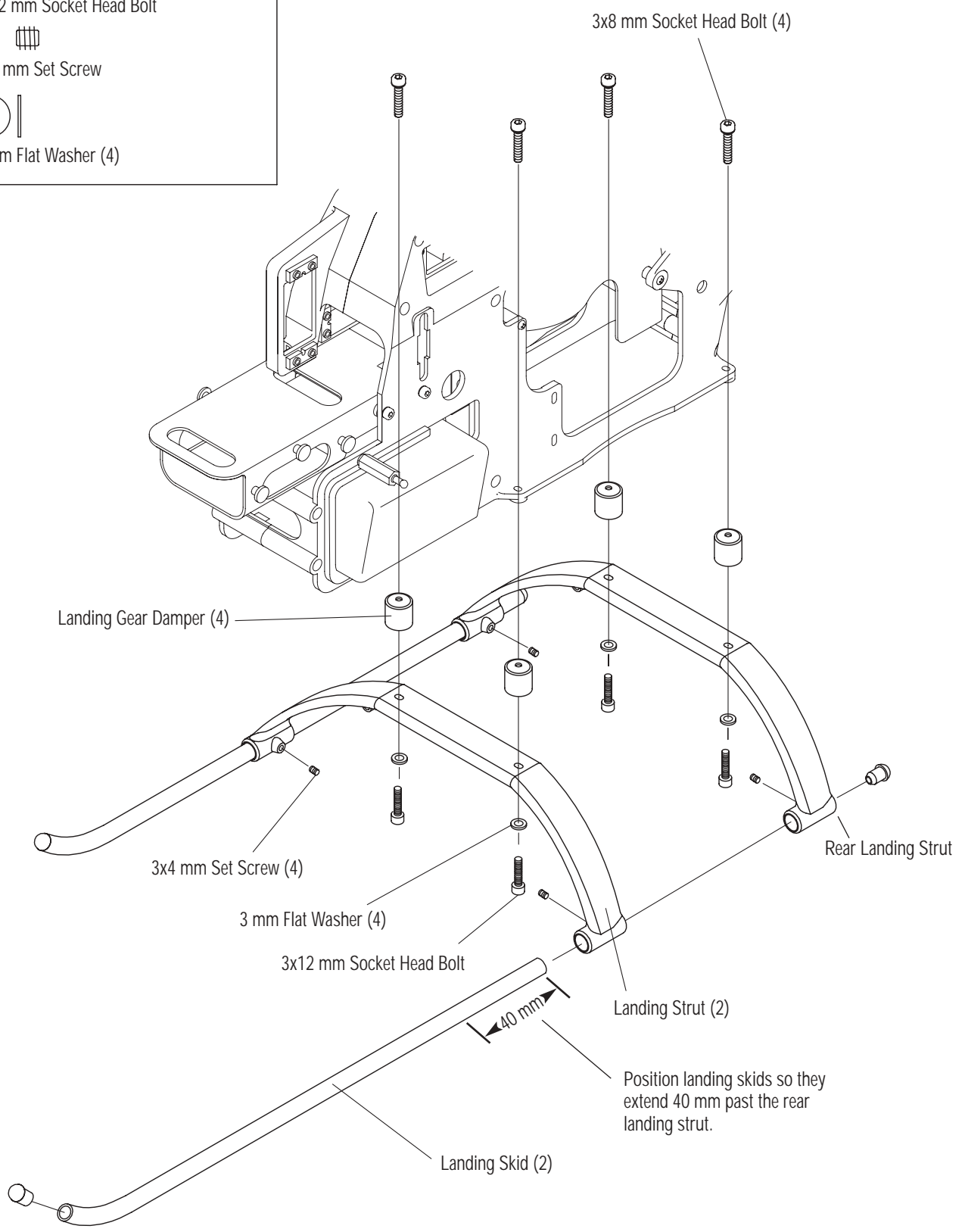







- 3x8 mm Socket Head Bolt
- 3x12 mm Socket Head Bolt
- 3x4 mm Set Screw
- 3 mm Flat Washer (4)



4-1

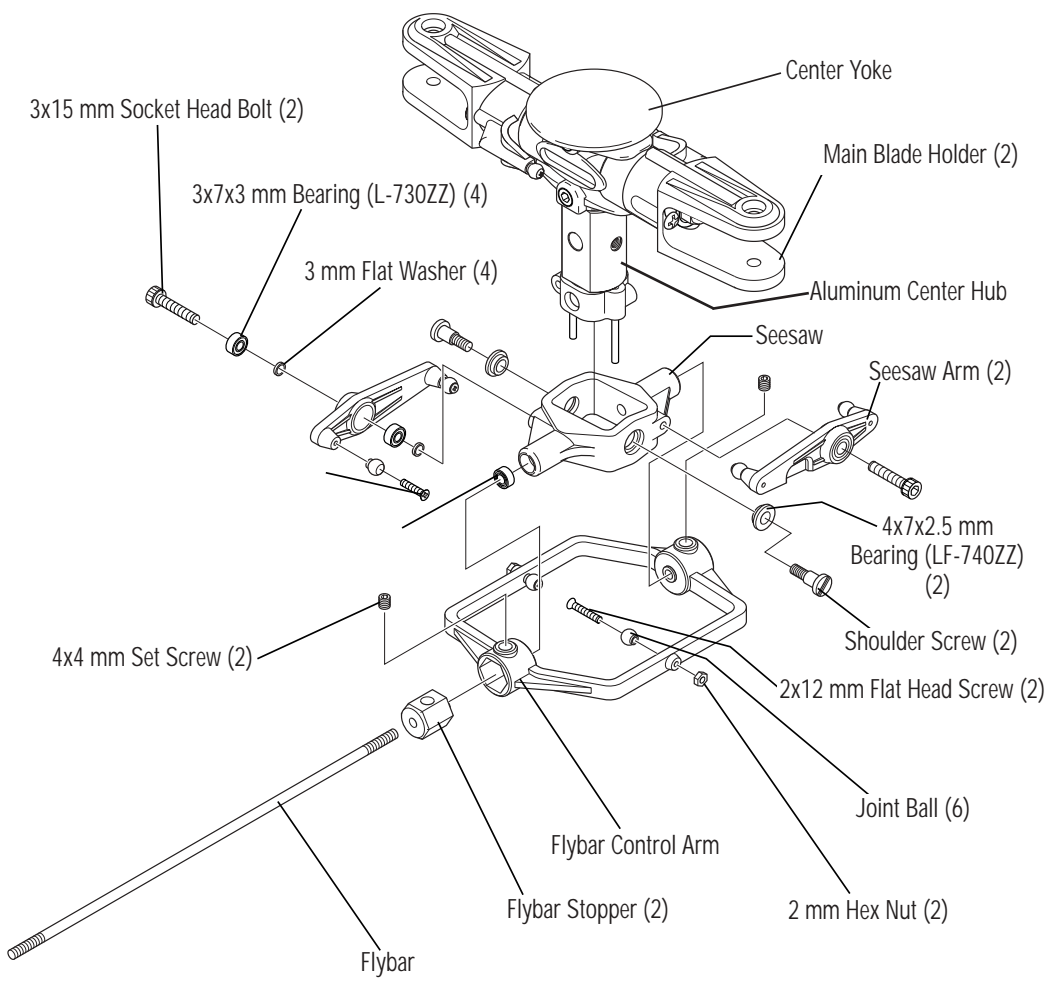

FLYBAR CONTROL ARM/SEESAW ARM ASSEMBLY

-  3x15 mm Socket Head Bolt (2)
-  2x10 mm Flat Head Screw (4)
-  2x12 mm Flat Head Screw (2)
-  3 mm Flat Washer (4)
-  2 mm Hex Nut (2)
-  Joint Ball (6)
-  4x4 mm Set Screw (2)
-  Shoulder Screw (2)
-  3x6x2.5 mm Bearing (L-630ZZ) (2)
-  3x7x3 mm Bearing (L-730ZZ) (4)
-  4x7x2.5 mm Bearing (LF-740ZZ) (2)



4-2

SPINDLE SHAFT/DAMPNER ASSEMBLY

-  4 mm Lock Nut (2)
-  Damper Rubber 3D (2)
-  Main Blade Spacer (2)

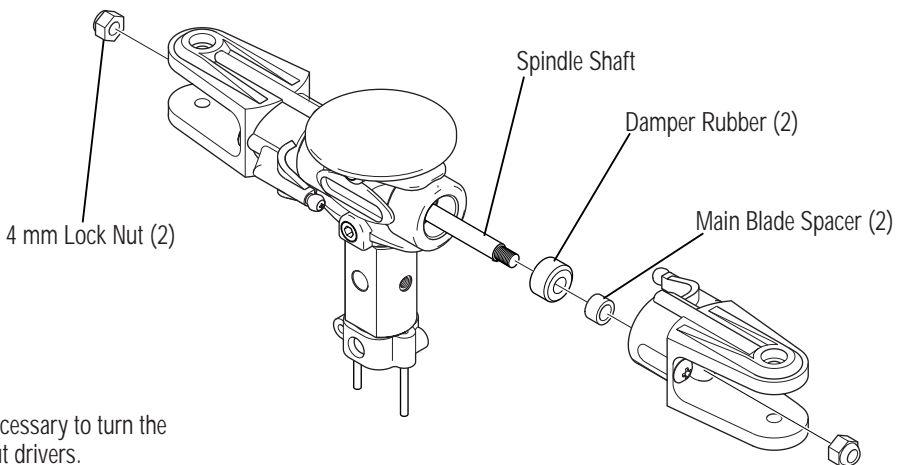

When removing the main blade holders, it will be necessary to turn the nuts both ends at a time using the two 7 mm hex nut drivers.

It will be necessary to remove one side of the main blade holders to remove the spindle shaft.

4-3

MAIN BLADE HOLDER ASSEMBLY

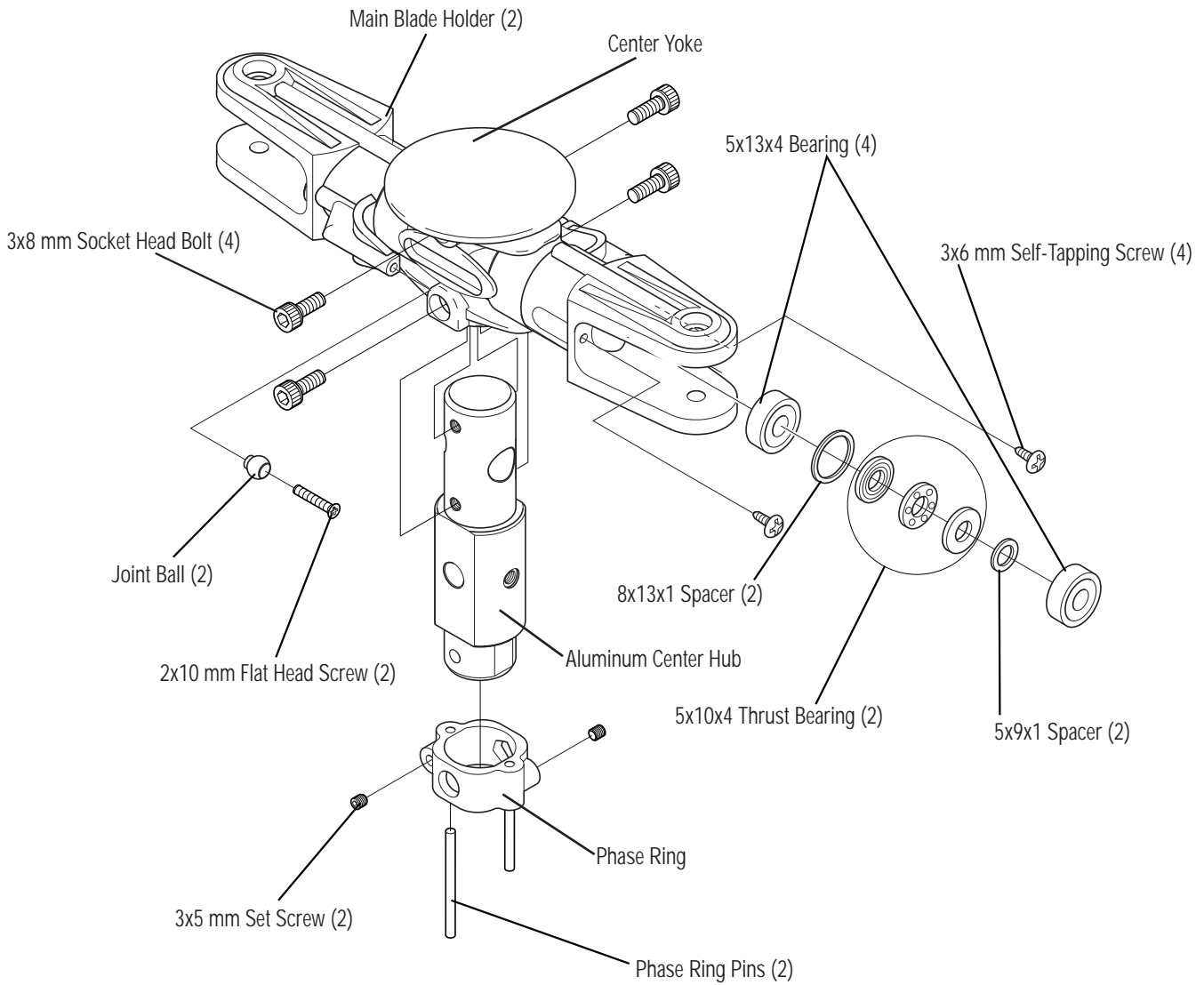
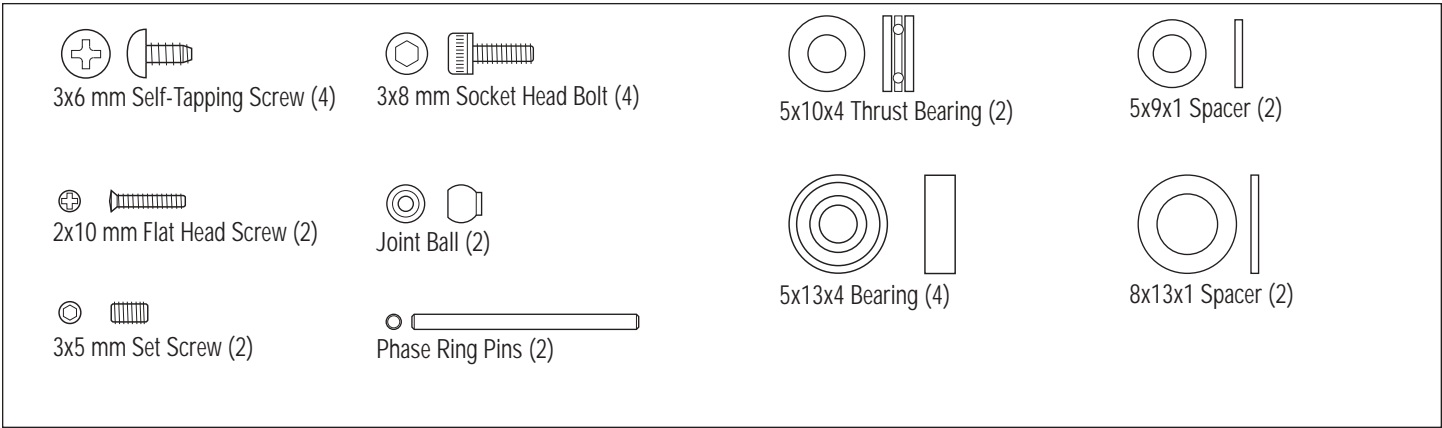

4-4

WASHOUT ASSEMBLY



3x15 mm Socket Head Bolt (2)



2x10 mm Flat Head Screw (2)



3 mm Flat Washer (2)

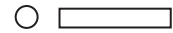

Washout Arm Pin (2)



2 mm CA Stopper Ring (4)



Joint Ball (2)

Be careful not to over-tighten the 3x15 mm socket head bolt.

If any clearance is detected between the washout arm and the washer base, an additional nylon washer (t0.13) can be used.

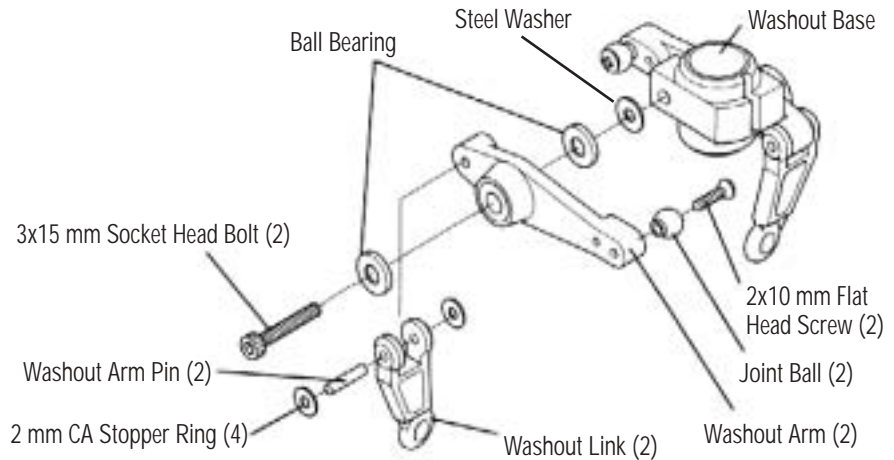

4-5

SWASHPLATE ASSEMBLY



4x4 mm Set Screws (3)

While holding the inside ball race, pivot the swashplate and check for excessive play. Adjust as necessary.

Swashplate Adjustment

The 120° CCPM swashplate is adjustable via the 3–4x4 mm set screws. If excessive play is found in the test above, gently tighten each of the 3–4 mm set screws the same amount and re-test. The swashplate should move freely, but without notable play.

Caution: If the 3–4 mm set screws are over tightened, damage to the swashplate bearings can occur.



Swashplate Adjustment Test

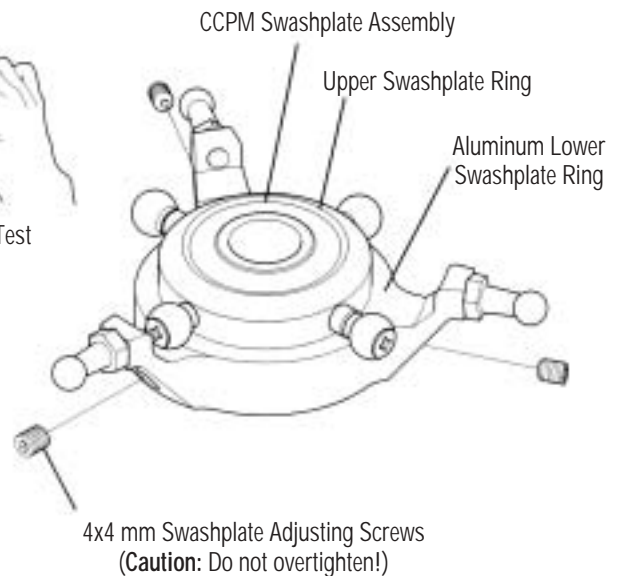

4-6

TAIL PITCH PLATE ASSEMBLY

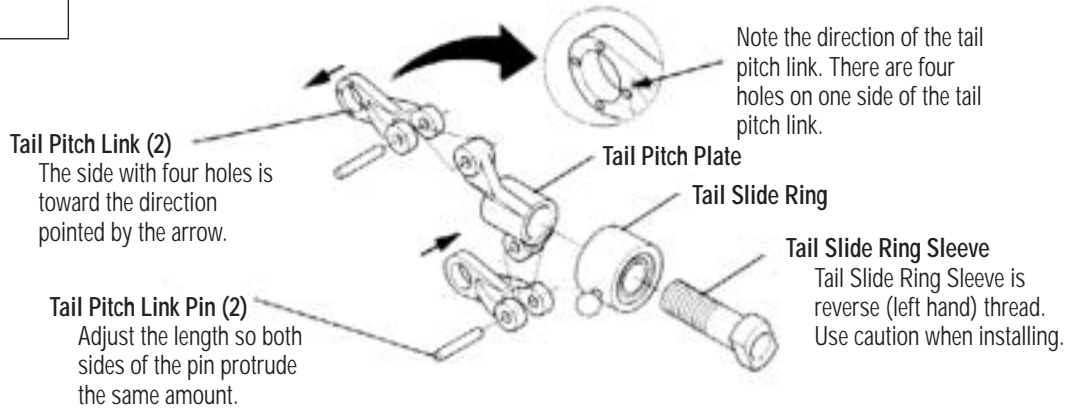
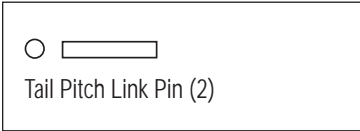

4-7

SWASHPLATE/WASHOUT ASSEMBLY INSTALLATION

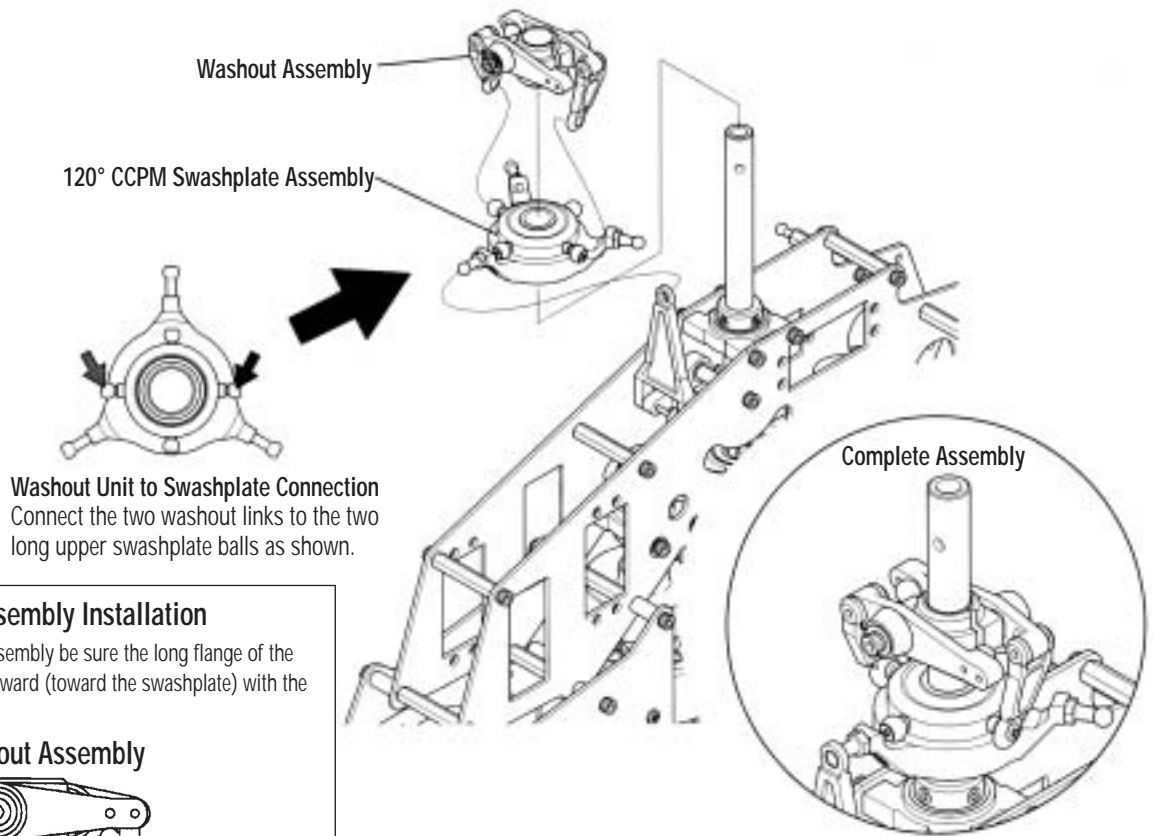

*Washout Assembly Installation

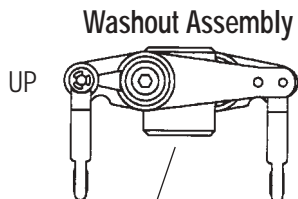

When installing the washout assembly be sure the long flange of the mixing base is positioned downward (toward the swashplate) with the short portion facing upward.







The long portion of mixing base flange must face downward.

4-8

ROTOR HEAD INSTALLATION

-  2.6x12 mm Socket Head Bolt (1)
-  3x20 mm Socket Head Bolt (1)
-  3 mm Flat Washer (1)

-  2.6 mm Lock Nut (1)
-  3 mm Lock Nut (1)
-  2x12 mm Flat Head Screw (2)

-  Steel Joint Ball (2)
-  2 mm Hex Nut (2)

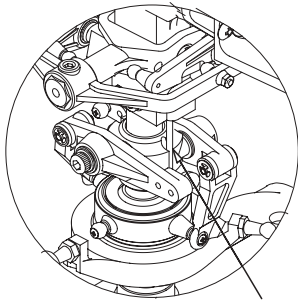

Note: Be sure to engage the rotor hub pin into the washout base groove before securing the rotor head in place.

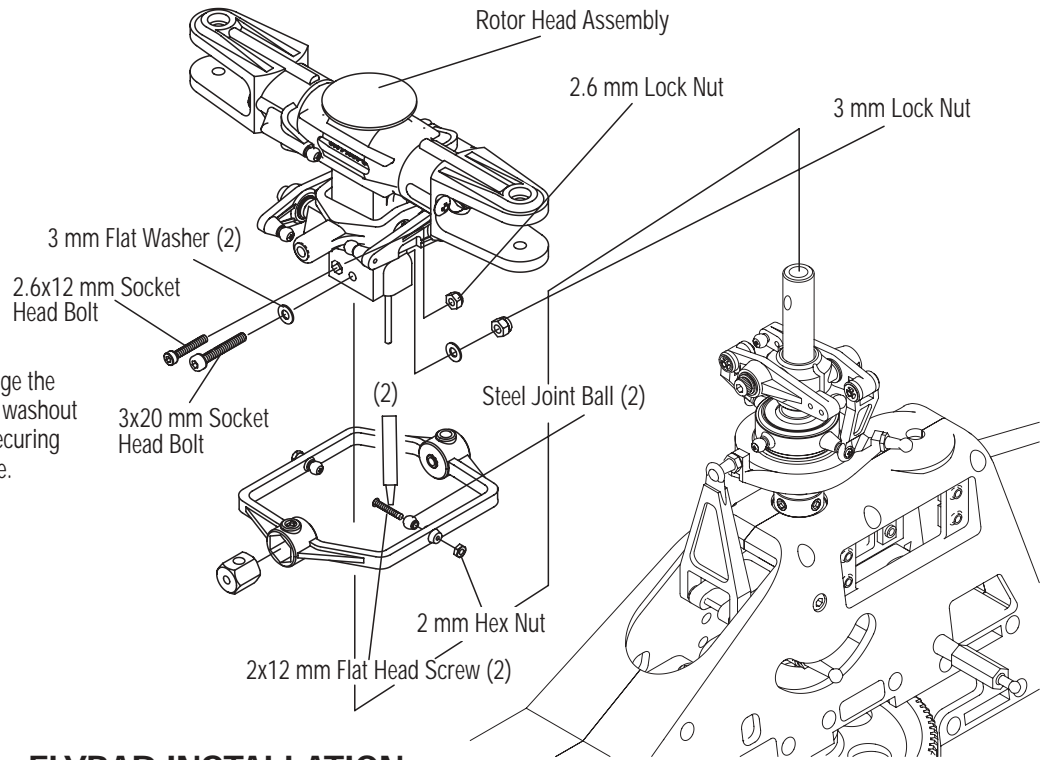

4-9

FLYBAR INSTALLATION

-  4x4 mm Set Screw



Center the flybar in the seesaw shaft before securing the flybar control arm.

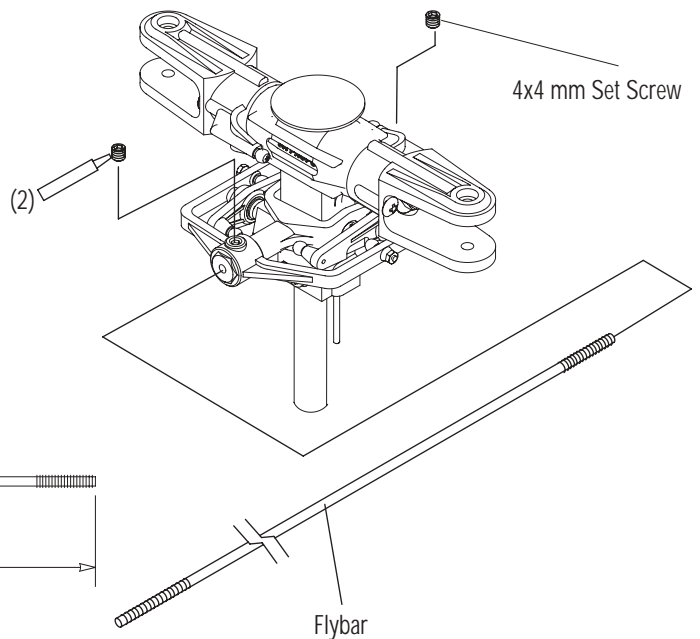

Adjust so that A and B are exactly the same length.

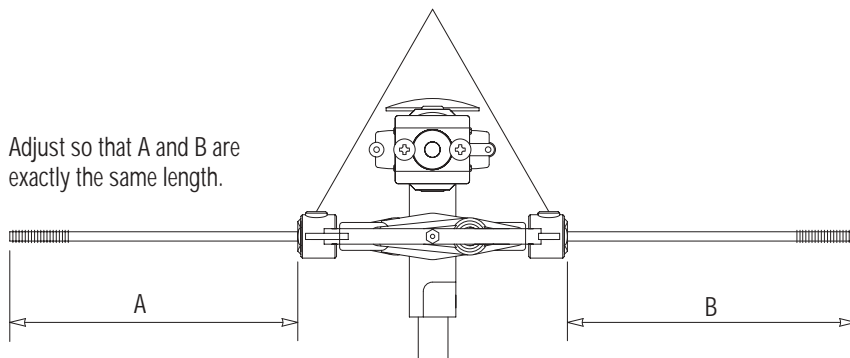

4-10

FLYBAR PADDLE ATTACHMENT (STANDARD 3D PADDLES)



Important:

Thread each flybar paddle onto the flybar until the threaded tip of the flybar protrudes approximately 5 mm.

Adjust each flybar paddle so they are parallel to the flybar control arms and to each other.

Note proper direction of each flybar paddle (short section forward, clockwise rotation).

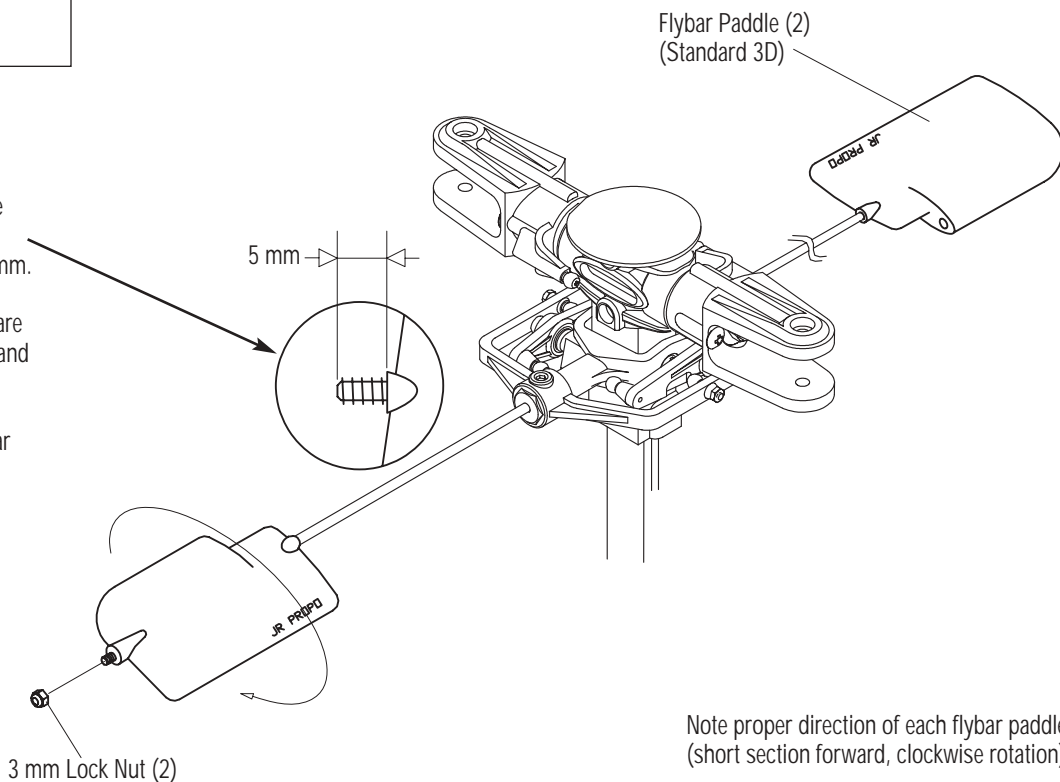

Note proper direction of each flybar paddle (short section forward, clockwise rotation).

4-11

ROTOR HEAD/SWASHPLATE CONTROL ROD INSTALLATION

Important:

Thread each universal link onto the 2.3 mm threaded rod to the length shown below. Note the correct direction of the universal link. Next, install each rod so the JR Propo logo faces outward.

Option: For smooth operation, pre-size the ball links with the JR ball link sizing tool prior to attachment.

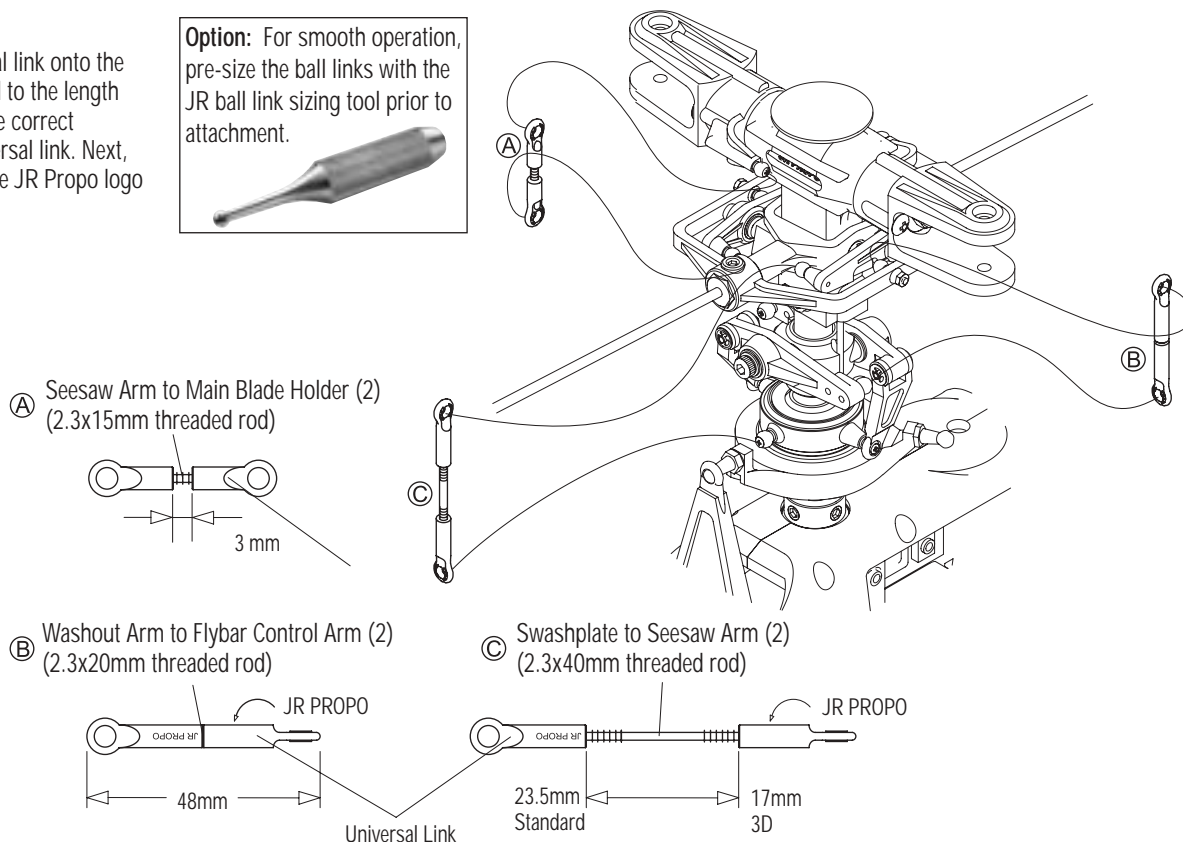

5-1

TAIL GEAR CASE PREPARATION

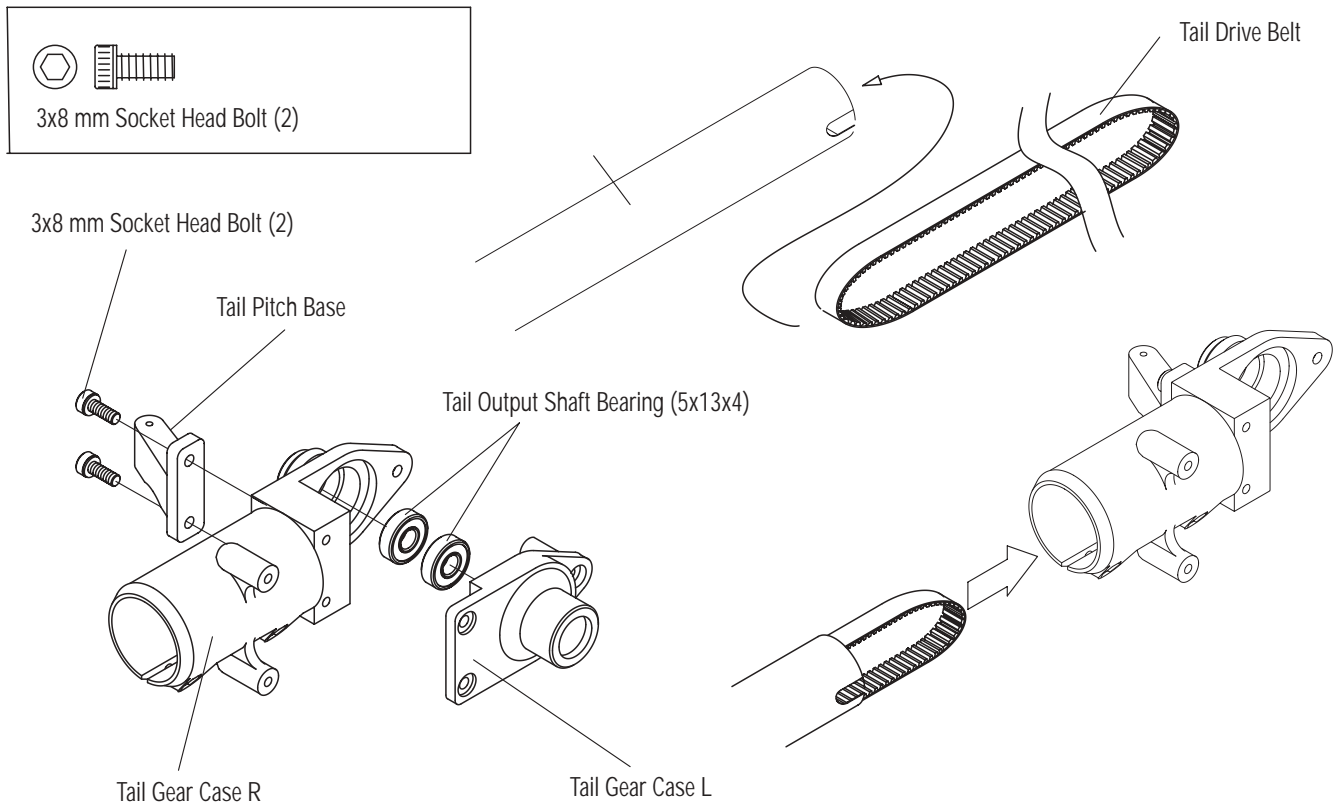

5-2

TAIL GEAR CASE ASSEMBLY

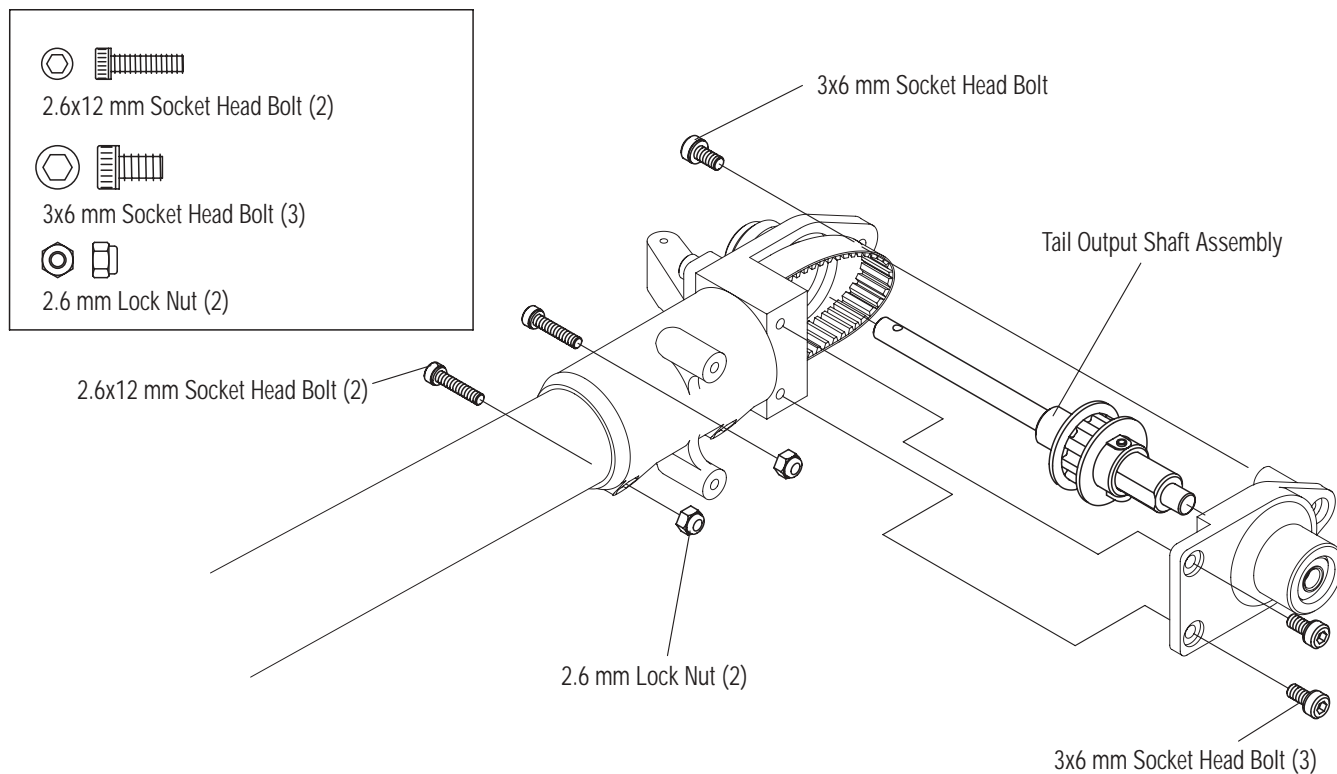

5-3

TAIL CENTER HUB ASSEMBLY



 3x3 mm Set Screw (2)



 3 mm Lock Nut (2)



 Use Red Threadlock

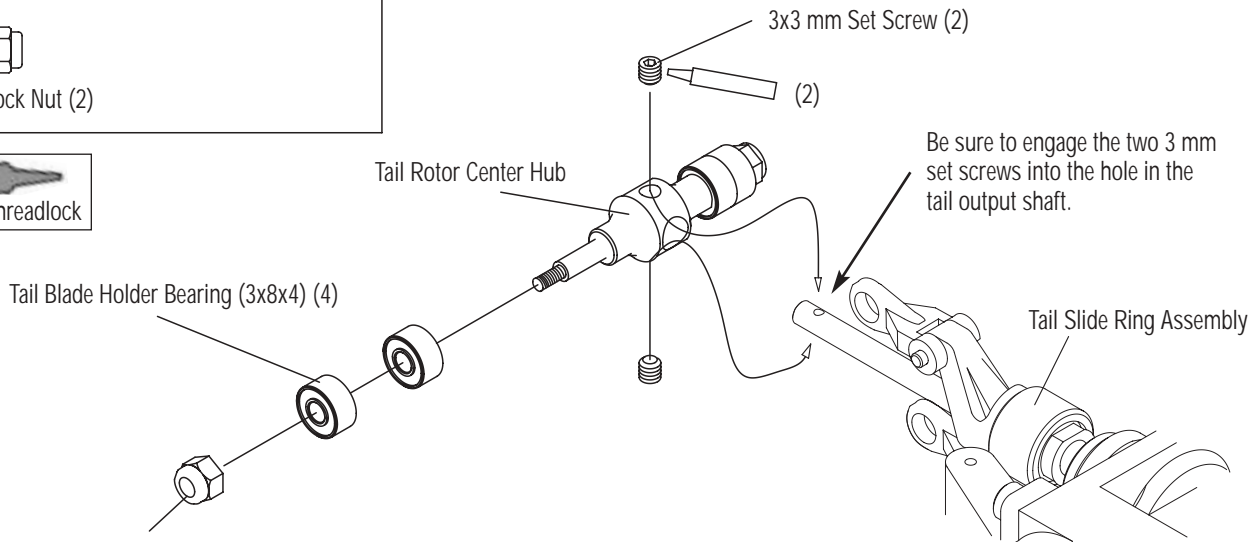

5-4

TAIL BLADE HOLDER ASSEMBLY



 2x8 mm Flat Head Screw (2)



 2x8 mm Socket Head Bolt (8)



 3x15 mm Socket Head Bolt (2)



 2 mm Hex Nut (8)



 3 mm Lock Nut (2)





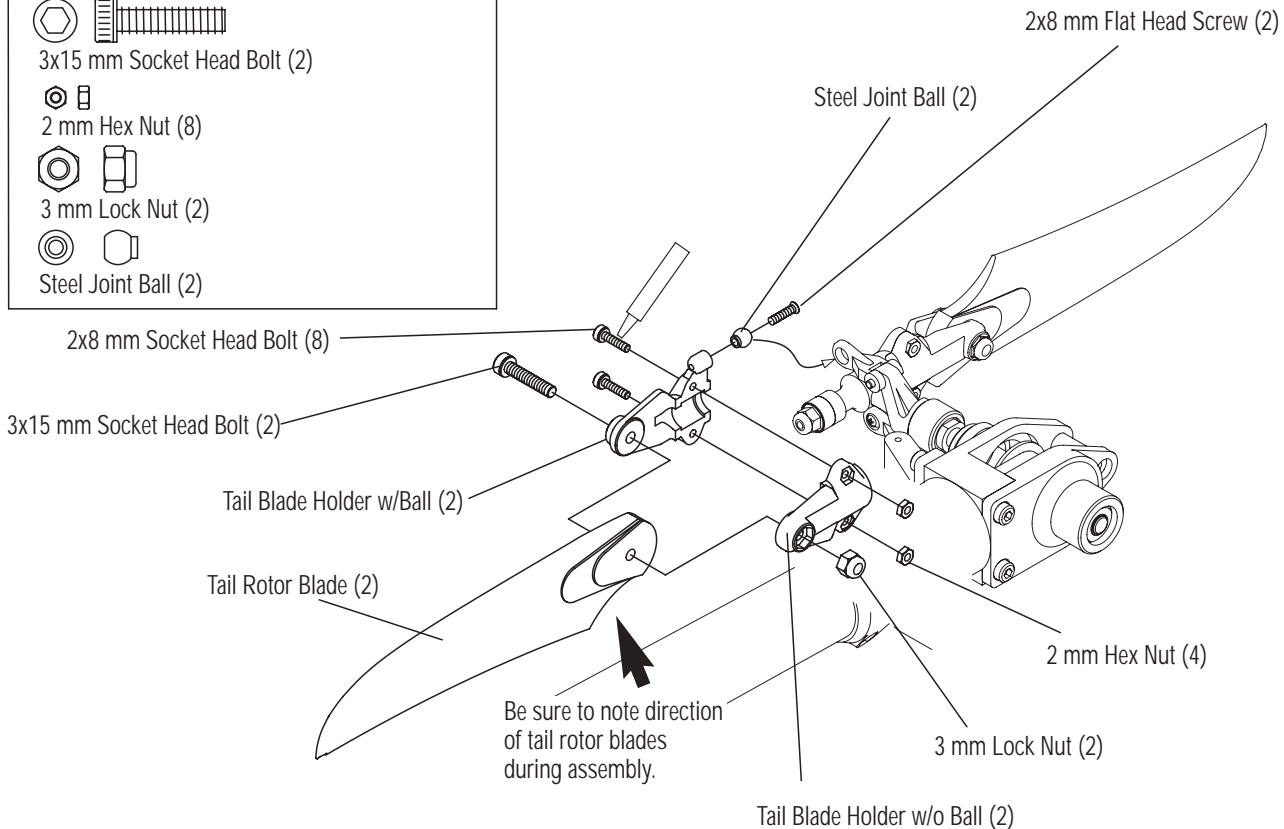

 Steel Joint Ball (2)



5-5



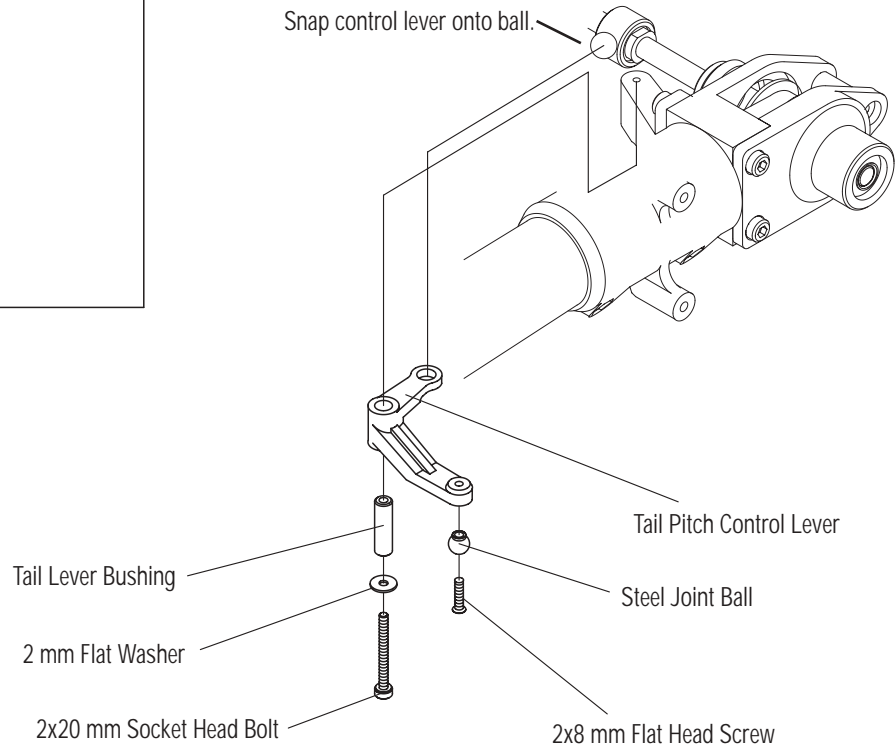

TAIL PITCH CONTROL LEVER INSTALLATION

-  2x8 mm Flat Head Screw (1)
-  2x8 mm Socket Head Bolt (1)
-  2 mm Flat Washer (1)
-  Steel Joint Ball (1)



5-6

TAIL BOOM BRACE ASSEMBLY (x2)

-  2x8 mm Socket Head Bolt (8)
-  2.6x15 mm Socket Head Bolt (4)
-  2 mm Hex Nut (8)
-  2.6 mm Lock Nut (4)

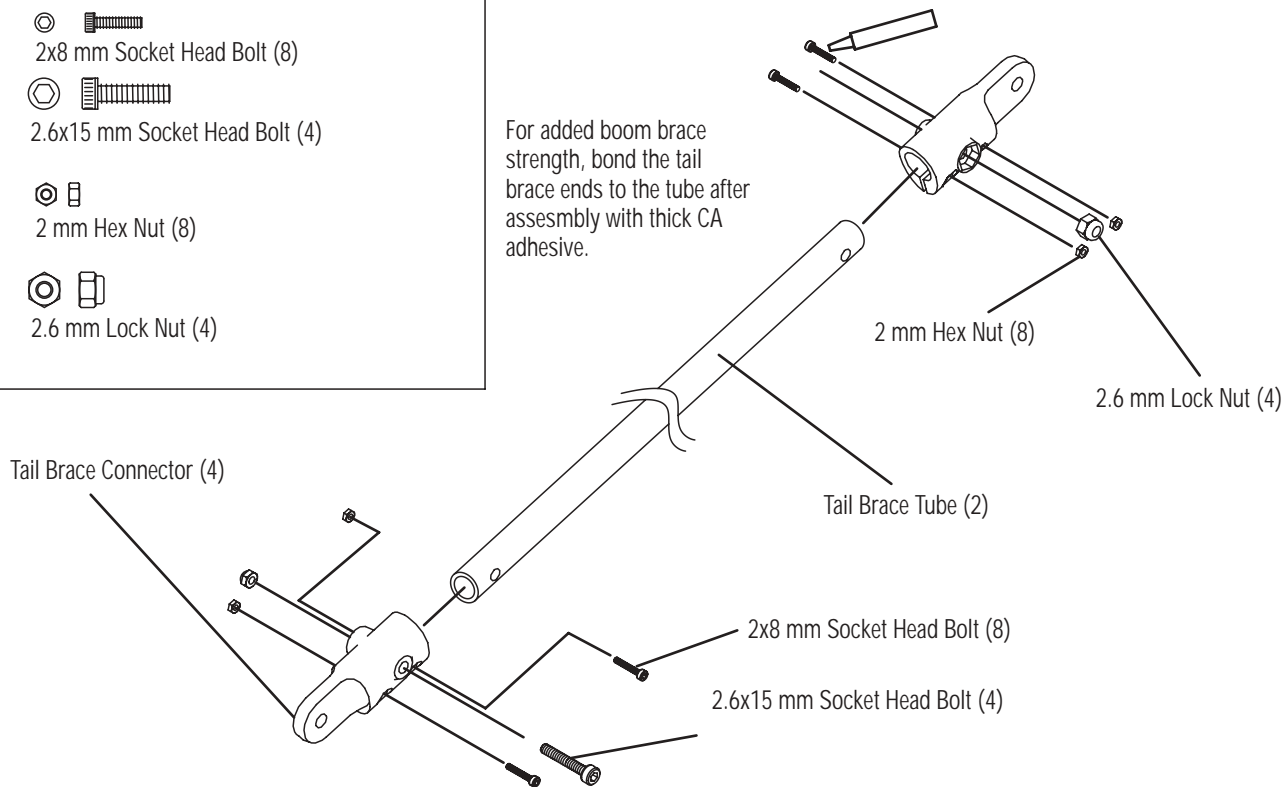

MAIN ROTOR HEAD ASSEMBLY

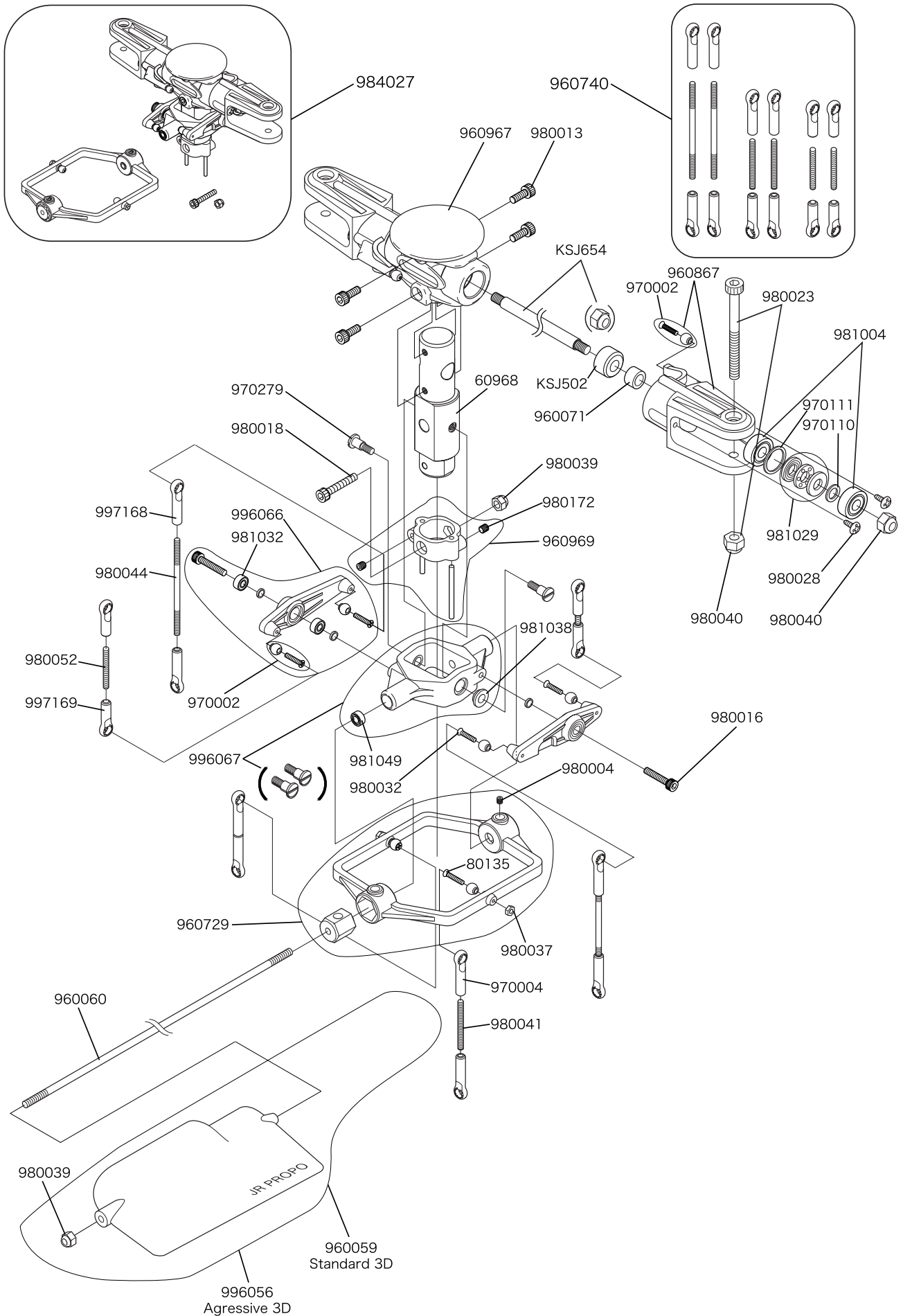

MAIN ROTOR HEAD ASSEMBLY PARTS

PART #	DESCRIPTION	COMMENTS/ADDITIONAL CONTENTS	QUANTITY
JRP960729	Flybar Control Arm	Flybar Control Arm	1
		Steel Joint Balls	2
		Flat Head Screw 2x12 mm	2
		2 mm Hex Nuts	2
		4x4 mm Set Screws	2
JRP960060	Flybar 540 mm	Flybar 540 mm (Training)	2
JRP996057	Flybar 410 mm	Flybar 410 mm (3D)	2
JRP980009	2.6x12 mm Socket Head Bolt	2.6x12 mm Socket Head Bolt	10
JRP980060	3x20 mm Socket Head Bolt	3x20 mm Socket Head Bolt	10
JRP980135	Flat Head Screw 2x12 mm	Flat Head Screw 2x12 mm	10
JRP960059	Flybar Paddle	Standard Flybar Paddle	2
		3mm Lock Nut	2
JRP996067	Seesaw Arm	Seesaw Arm	2
		Seesaw Bearing Inner	2
		Steel Joint Ball	4
		Flat Head Screw M2x10	4
JRP996056	3D Flybar Paddle	3D Flybar Paddle	2
JRP997168	Universal Ball Links, Black	Universal Ball Links, Black	10
JRP997169	Universal Ball Links Short, Black	Universal Ball Links Short, Black	5
JRP980052	Control Rod M2.3x15	Control Rod M2.3x15	2
JRP980041	Control Rod M2.3x20	Control Rod M2.3x20	2
JRP980044	Control Rod M2.3x40	Control Rod M2.3x40	2
JRP980023	Main Blade Bolt	Main Blade Bolt 4x30 mm	2
JRP984027	Main Rotor Head Assembly	Main Rotor Head Assembly	1
JRP960968	Aluminum Main Rotor Hub	Main Rotor Hub	1
JRP960969	Phase Ring w/Pins	Phase Ring with Pins	1
JRP960967	Plastic Yoke	Plastic Yoke with screws	1
JRP970279	Seesaw Shaft Bolt	Seesaw Shaft Bolt	2
KSJ654	Heavy Duty Spindle Shaft	Spindle Shaft	1
KSJ502	Damper Rubber 3D	Damper Rubber	2
JRP960071	Damper Collar	Damper Collar	2
JRP981029	Thrust Bearing Set	Thrust Bearings	2
JRP980028	Self-Tapping Screw 3x6 mm	Self Tapping Screw 3x6 mm	10
JRP980040	4 mm Lock Nut	4mm Lock Nut	10
JRP960867	Main Blade Holder	Main Blade Holder	2
		Steel Joint Ball	2
		Flat Head Screw 2x10 mm	2
JRP996067	Seesaw Shaft	Seesaw Shaft	1
		Seesaw Shaft Bolt	2
JRP960740	Head Linkage Set	Control Rod M2.3x40	2
		Control Rod M2.3x20	2
		Control Rod M2.3x15	2
		Ball Links, Long	8
		Ball Links, Short	4
JRP970002	Joint Balls/2x10 mm Screws	Joint Balls/2x10 mm Screws	10
JRP981004	Ball Bearings, 5x13x4 mm	Ball Bearings, 5x13x4 mm	2
JRP980039	Lock Nuts, 3 mm	Lock Nuts, 3 mm	10
JRP980129	Lock Nuts, 2.6 mm	Lock Nuts, 2.6 mm	10
JRP981032	Washout Arm Bearings	Washout Arm Bearings	2
JRP981038	Seesaw Pivot Bearings	Seesaw Pivot Bearings	2
JRP981049	Seesaw/Flybar Bearings	Seesaw/Flybar Bearings	2
JRP980032	Flat Head Screws, 2x10 mm	Flat Head Screws, 2x10 mm	10
JRP980037	Hex Nuts, 2 mm	Hex Nuts, 2 mm	10
JRP980069	Set Screws, 4x6 mm	Set Screws, 4x6 mm	10
JRP980004	Set Screws, 4x4 mm	Set Screws, 4x4 mm	10

CONTROL SYSTEM ASSEMBLY

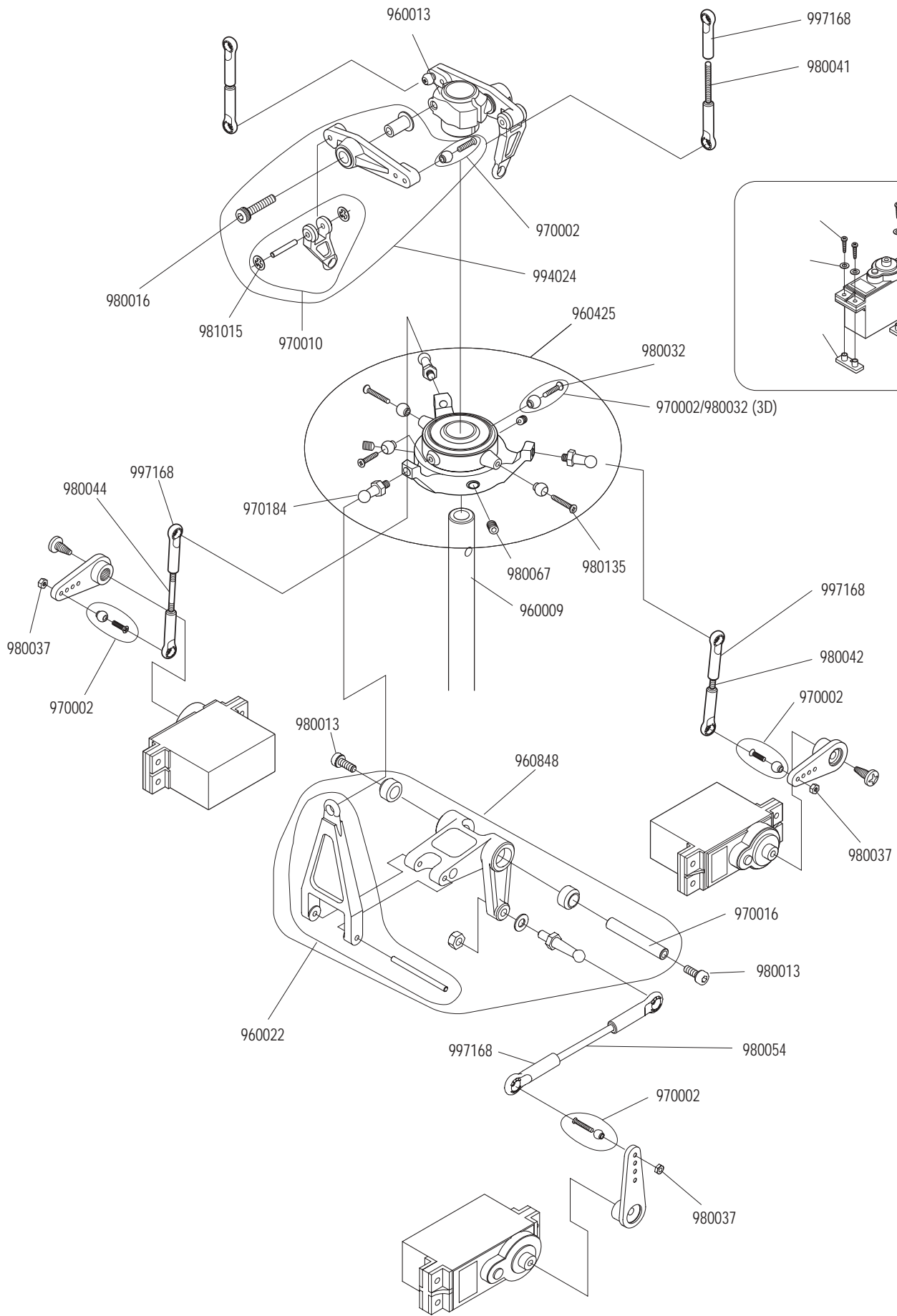

CONTROL SYSTEM ASSEMBLY PARTS

PART #	DESCRIPTION	COMMENTS/ADDITIONAL CONTENTS	QUANTITY
JRP960848	V Elevator Arm	Elevator Arm Elevator Arm Bushing Long Ball Arm 14.5 Elevator Arm Pin L32 3 mm Lock Nut 3 mm Flat Washer Swashplate Arm Swashplate Arm Pin	1 2 1 1 1 1 1 1
JRP960022	Swashplate A Arm	Swashplate Arm Swashplate Arm Pin	1 1
JRP970016	Elevator Arm Bushing 32 mm	Elevator Arm Bushing 32 mm	2
JRP970323	Servo Mounting Plate	Servo Mounting Plate	10
JRP970184	Ball Arm 9 mm	Ball Arm 9 mm	1
JRP960425	120 Deg. Alum. Swashplate Assm.	120 Deg. Swashplate Assembly Steel Joint Ball Ball Arm 9mm Flat Head Screw 2x10 mm Flat Head Screw 2x12 mm 3x3 mm Set Screw	1 4 3 2 2 3
JRP970078	Joint Ball Spacer, 2.75 mm (3D)	Joint Ball Spacer	2
JRP960013	Washout Base	Washout Base	1
JRP980032	Flat Head Screw, 2x10 mm	Flat Head Screw, 2x10 mm	10
JRP980054	Control Rod M2.3x65	Control Rod M2.3x65	2
JRP980042	Control Rod M2.3x30	Control Rod M2.3x30	2
JRP981015	CA Stopper Ring 2 mm	CA Stopper Ring 2 mm	10
JRP994024	Washout Arm	Washout Arm Washout link Washout Bearing Shaft 4 mm Washout Link Pin Washout Bearing Collar M3x15 CAP.B Steel Joint Ball Flat Head Screw M2x10	2 2 2 2 2 2 2 2
JRP981021	Ball Bearing 4x8x3 mm (L-840ZZ)	Ball Bearing 4x8x3 mm (L-840ZZ)	2
JRP970010	Washout Link	Washout Link Washout Link Pin CA Stopper Ring	2 2 4
JRP997168	Universal Ball Link, Black	Universal Ball Link, Black	10
JRP960009	Main Rotor Shaft	Main Rotor Shaft	1
JRP980041	Control Rod, 2.3x20 mm	Control Rod, 2.3x20 mm	2
JRP980016	Socket Head Bolt, 3x15 mm	Socket Head Bolt, 3x15 mm	10
JRP970002	Joint Balls/2x10 mm Screws	Joint Balls/2x10 mm Screws	10
JRP980027	Self Tapping Screws, 2.6x12 mm	Self Tapping Screws, 2.6x12 mm	10
JRP980035	Plate Washer, 2.6 mm	Plate Washer, 2.6 mm	10
JRP980044	Control Rod, 2.3x40 mm	Control Rod, 2.3x40 mm	2
JRP980037	Hex Nuts, 2 mm	Hex Nuts, 2 mm	10
JRP980067	Set Screws, 3x3 mm Set Screws, 3x3 mm		10
JRP980135	Flat Head Screw, 2x12 mm	Flat Head Screw, 2x12 mm	10
JRPA215	Heavy-Duty Servo Arms	Heavy-Duty Servo Arms	2

MAIN FRAME/DRIVE GEAR ASSEMBLY

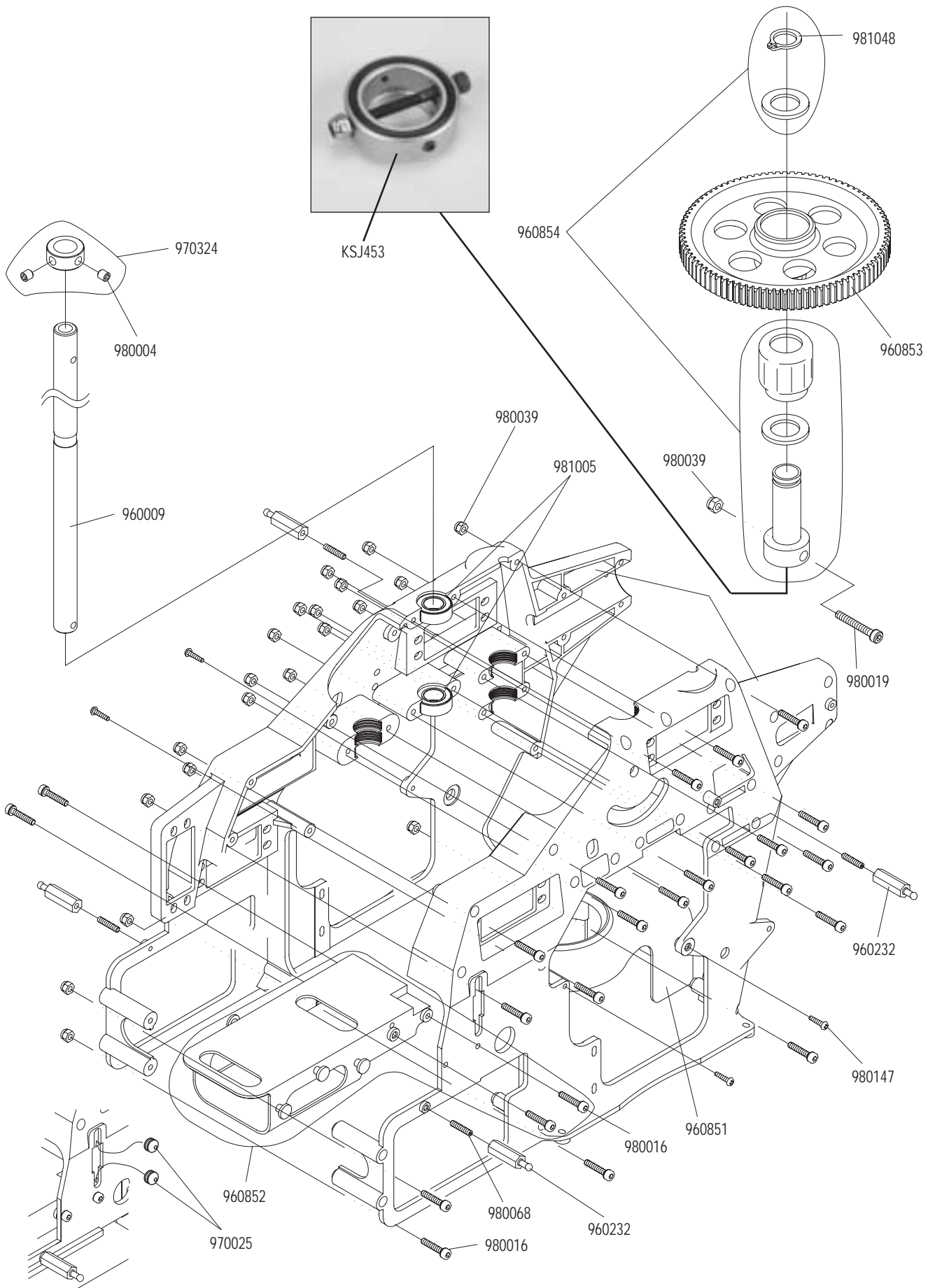

MAIN FRAME/DRIVE GEAR ASSEMBLY PARTS

PART #	DESCRIPTION	COMMENTS/ADDITIONAL CONTENTS	QUANTITY
JRP960850	Main Frame L/R	Main Frame R	1
		Main Frame L	1
JRP980068	3x15 mm Set Screw	3x15 mm Set Screw	10
JRP960232	Body Mounting Standoff L21	Body Mounting Standoff L21	2
JRP980013	3x8 mm Socket Head Bolt	3x8 mm Socket Head Bolt	10
JRP980039	3 mm Lock Nut	3mm Lock Nut	10
JRP960851	Cooling Fan Shroud	Cooling Fan Shroud	1
		2.6x10 mm Self-Tapping Screw	4
		2.6 mm Flat Washers	4
JRP980147	M2.6x10 Self-Tapping Screw	2.6x10 mm Self-Tapping Screw	10
JRP960852	Front Radio Bed	Front Radio Bed	1
		3x10 mm Socket Head Bolts	4
JRP970324	Main Shaft Collar	Main Shaft Collar	1
		4x4 mm Set Screw	2
JRP980004	4x4 mm Set Screw	4x4 mm Set Screw	10
JRP980019	3x22 mm Socket Head Bolt	3x22 mm Socket Head Bolt	10
JRP960853	Main Drive Gear 88T	Main Drive Gear 88T	1
JRP960854	Autorotation Bearing Assembly	One-way Bearing	1
KSJ453	LSD Clutch	LSD clutch with o-ring	1
		Autorotation Shaft	1
		Autorotation Spacer	2
		CA Stopper Ring 11 mm	1
JRP981048	CA Stopper Ring 11 mm	CA Stopper Ring 11 mm	1
JRP960009	Main Rotor Shaft	Main Rotor Shaft	1
JRP981005	Main Rotor Shaft Bearings	Main Rotor Shaft Bearings	2
JRP980016	Socket Head Bolts, 3x15 mm	Socket Head Bolts, 3x15 mm	10
JRP970025	Switch Damper Rubber	Switch Damper Rubber	4

ENGINE/CLUTCH/TAIL DRIVE PULLEY ASSEMBLY

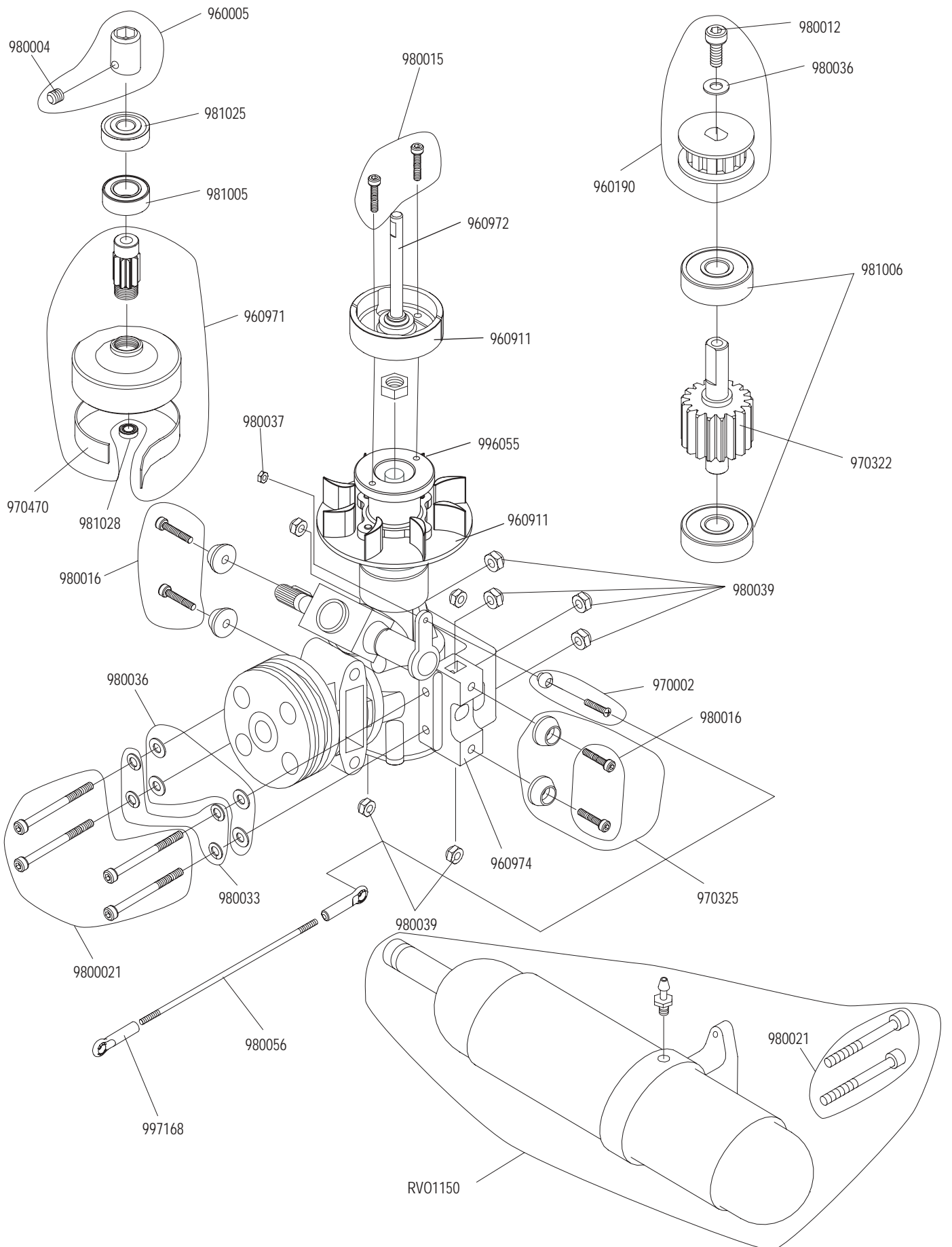

ENGINE/CLUTCH/TAIL DRIVE PULLEY ASSEMBLY PARTS

PART #	DESCRIPTION	COMMENTS/ADDITIONAL CONTENTS	QUANTITY
JRP981005	Ball Bearing 10x19x7 mm	Ball Bearing 10x19x7 mm	2
JRP960971	Clutch Bell Assembly	Clutch Bell Assembly	1
JRP970470	Clutch Lining	Clutch Lining	1
JRP970322	Tail Drive Pinion	Tail Drive Pinion	1
		3x6 mm Socket Head Bolt	1
		3 mm Flat Washer	1
JRP960190	Front Tail Belt Pulley	Front Tail Belt Pulley	1
		3x6 mm Socket Head Bolt	1
		3 mm Flat Washer	1
JRP981006	Ball Bearing 6x19x6 mm	Ball Bearing 6x19x6 mm	2
JRP981025	Ball Bearing 5x19x6 mm	Ball Bearing 5x19x6 mm	2
JRP980016	3x15 mm Socket Head Bolt	3x15 mm Socket Head Bolt	10
JRP980021	3x30 mm Socket Head Bolt	3x30 mm Socket Head Bolt	10
JRP980033	3mm Spring Washer	3mm Spring Washer	10
JRP960974	Engine Mount .50 (Aluminum)	Engine Mount .50	1
JRP996054	Cooling Fan Blades	Fan Blades & Screws	1
JRP996055	Cooling Fan Hub	Cooling Fan Hub	1
JRP960972	Clutch Assembly w/ Bearing	Clutch Assembly w/Bearing	1
		3x12 mm Socket Head Bolt	2
JRP970325	Engine Mount/Frame Washers	Engine Mount/Frame Washers	4
		3x12 mm Socket Head Bolt	4
		3mm Lock Nut	4
JRP960005	Starter Hex Adaptor	Starter Hex Adaptor	1
		4x4 mm Set Screw	1
JRP960471	Starter Shaft	Starter Shaft	1
JRP981007	Ball Bearing 20x32x7 mm	Ball Bearing 20x32x7 mm	1
JRP980056	Control Rod M2.3x85	Control Rod M2.3x85	2
JRP980004	Set Screws, 4x4 mm	Set Screws, 4x4 mm	10
JRP981028	Clutch Bell Bearing	Clutch Bell Bearing	1
JRP980015	Socket Head Bolts, 3x12 mm	Socket Head Bolts, 3x12 mm	10
JRP980036	Plate Washers, 3 mm	Plate Washers, 3 mm	10
JRP980039	Lock Nuts, 3 mm	Lock Nuts, 3 mm	10
JRP970002	Joint Balls/2x10 mm Screws	Joint Balls/2x10 mm Screws	10
JRP997168	Universal Ball Link, Black	Universal Ball Link, Black	10
RVO1150	Muffler, .46-.50	Muffler, .46-.50	1

BODY SET/FUEL TANK/LANDING GEAR ASSEMBLY

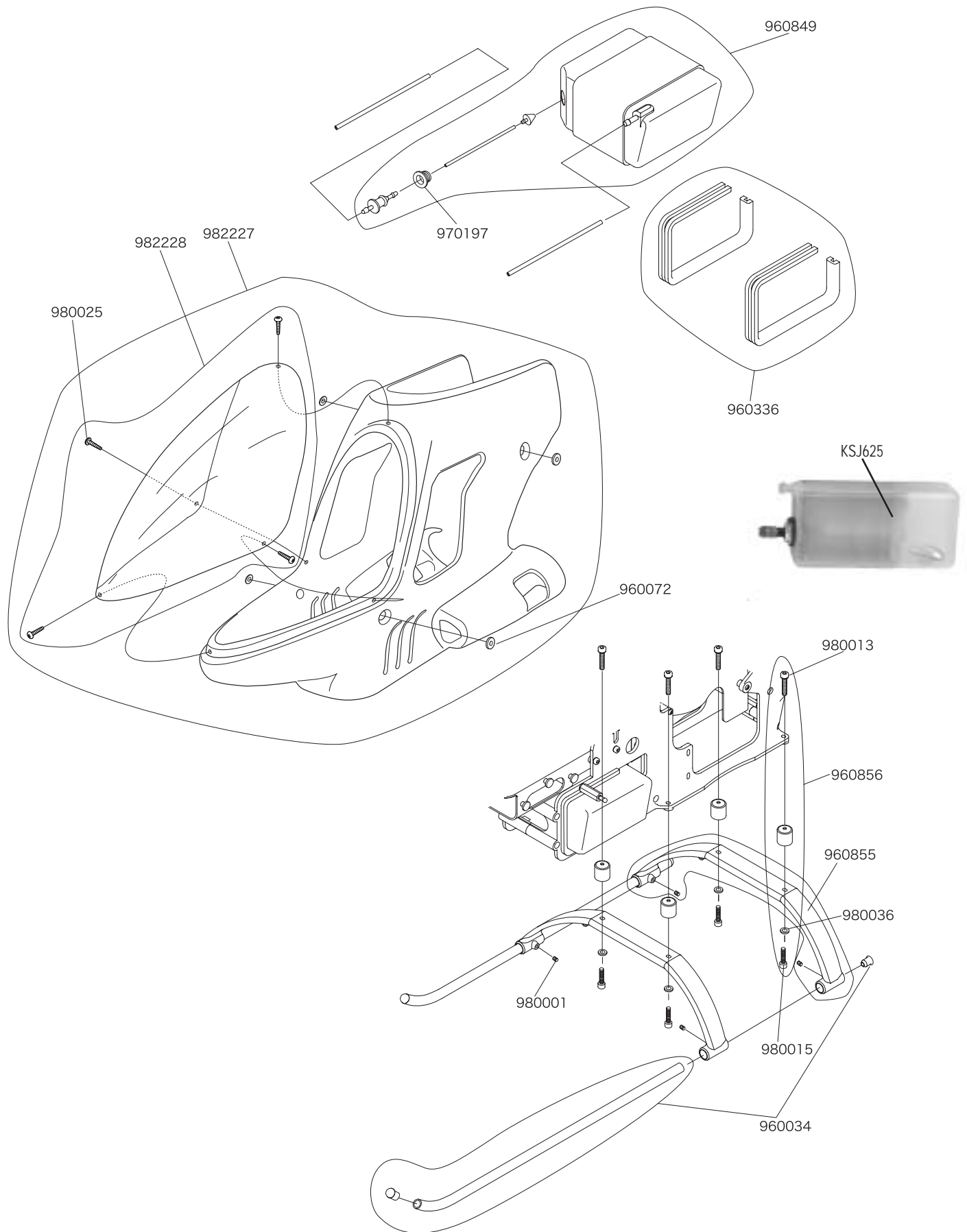

BODY SET/FUEL TANK/LANDING GEAR ASSEMBLY PARTS

PART #	DESCRIPTION	COMMENTS/ADDITIONAL CONTENTS	QUANTITY
JRP960849	Fuel Tank Assembly Fuel Tank	1 Fuel Tank Clunk Nipple Tank Grommet Silicone Tube(Small)	1 1 1 1
JRP960336	Tank Mounting Rubber	Tank Mounting Rubber (1 m)	1
JRP970197	Tank Grommet	Tank Grommet	2
JRP960855	Landing Struts	Landing Struts 3x4 mm Set Screw	2 4
JRP980001	3x4 mm Set Screw	3x4 mm Set Screw	10
JRP960034	Landing Skids	Landing Skids Landing Skid Caps	2 4
JRP980015	3x12 mm Socket Head Bolt	3x12 mm Socket Head Bolt	10
JRP980036	3 mm Flat Washer	3 mm Flat Washer	10
JRP982244	Venture 50 Body Set	Body Canopy 2.3x8 mm Self-Tapping Screw Rubber Grommet	1 1 4 4
JRP982245	Canopy	Canopy 2.3x8 mm Self-Tapping Screw	1 4
JRP960856	Landing Gear Dampers	Landing Gear Dampers 3x8 mm Socket Head Bolt 3x12 mm Socket Head Bolt 3mm Flat Washer	4 4 4 4
JRP960072	Rubber Grommet	Rubber Grommet	4
JRP980025	Self-Tapping Screws, 2.3x8 mm	Self-Tapping Screws, 2.3x8 mm	10
JRP980013	Socket Head Bolts, 3x8 mm	Socket Head Bolts, 3x8 mm	10

TAIL BOOM/TAIL FIN/TAIL BRACE ASSEMBLY PARTS

PART #	DESCRIPTION	COMMENTS/ADDITIONAL CONTENTS	QUANTITY
JRP980129	2.6 mm Lock Nut	2.6 mm Lock Nut	10
JRP980014	3x10 mm Socket Head Bolt	3x10 mm Socket Head Bolt	10
JRP996064	Horizontal Fin	Horizontal Fin	1
JRP960865	Fin Set	Horizontal and Vertical Fins	1
JRP983012	Tail Boom	Tail Boom	1
JRP983035	Dual Tail Brace Set	Tail Brace Tube 430 mm	2
		Tail Brace Connector	4
		3x15 mm Socket Head Bolt	4
		2.6x15 mm Socket Head Bolt	4
		2x8 mm Socket Head Bolt	8
		3 mm Lock Nut	4
		2.6 mm Lock Nut	4
		2 mm Hex Nut	8
JRP960866	Tail Brace Clamp	Tail Brace Clamp U	1
		Tail Brace Clamp L	1
		3x12 mm Socket Head Bolt	2
		3x15 mm Socket Head Bolt	1
		3mm Lock Nut	3
		3mm Flat Washer	2
JRP983078	Tail Control Rod 965mm	Tail Control Rod 965 mm	1
		Universal Link	2
JRP960293	Tail Rod Guide B Set	Tail Rod Guide B Set	4
		Rod Guide	1
		Tail Control Rod Guide B	4
		Tail Control Rod Bush	1
		3x10 mm Socket Head Bolt	1
		2x8 mm Socket Head Bolt	4
JRP983034	Tail Control Tubing 600 mm	Tail Control Tubing 600 mm	2
JRP980024	Self-Tapping Screws, 2x8 mm	Self-Tapping Screws, 2x8 mm	10
JRP980039	Lock Nuts, 3 mm	Lock Nuts, 3 mm	10
JRP997168	Universal Ball Link, Black	Universal Ball Link, Black	10
JRP981015	CA Stopper Ring, 2 mm	CA Stopper Ring, 2 mm	10
JRP980016	CA Stopper Ring, 1.5 mm	CA Stopper Ring, 1.5 mm	10
JRP980036	Plate Washers, 3 mm	Plate Washers, 3 mm	10
JRP980006	Socket Head Bolts, 2x8 mm	Socket Head Bolts, 2x8 mm	10
JRP980010	Socket Head Bolts, 2.6x15 mm	Socket Head Bolts, 2.6x15 mm	10
JRP980037	Hex Nuts, 2 mm	Hex Nuts, 2 mm	10

TAIL CASE/TAIL ROTOR ASSEMBLY

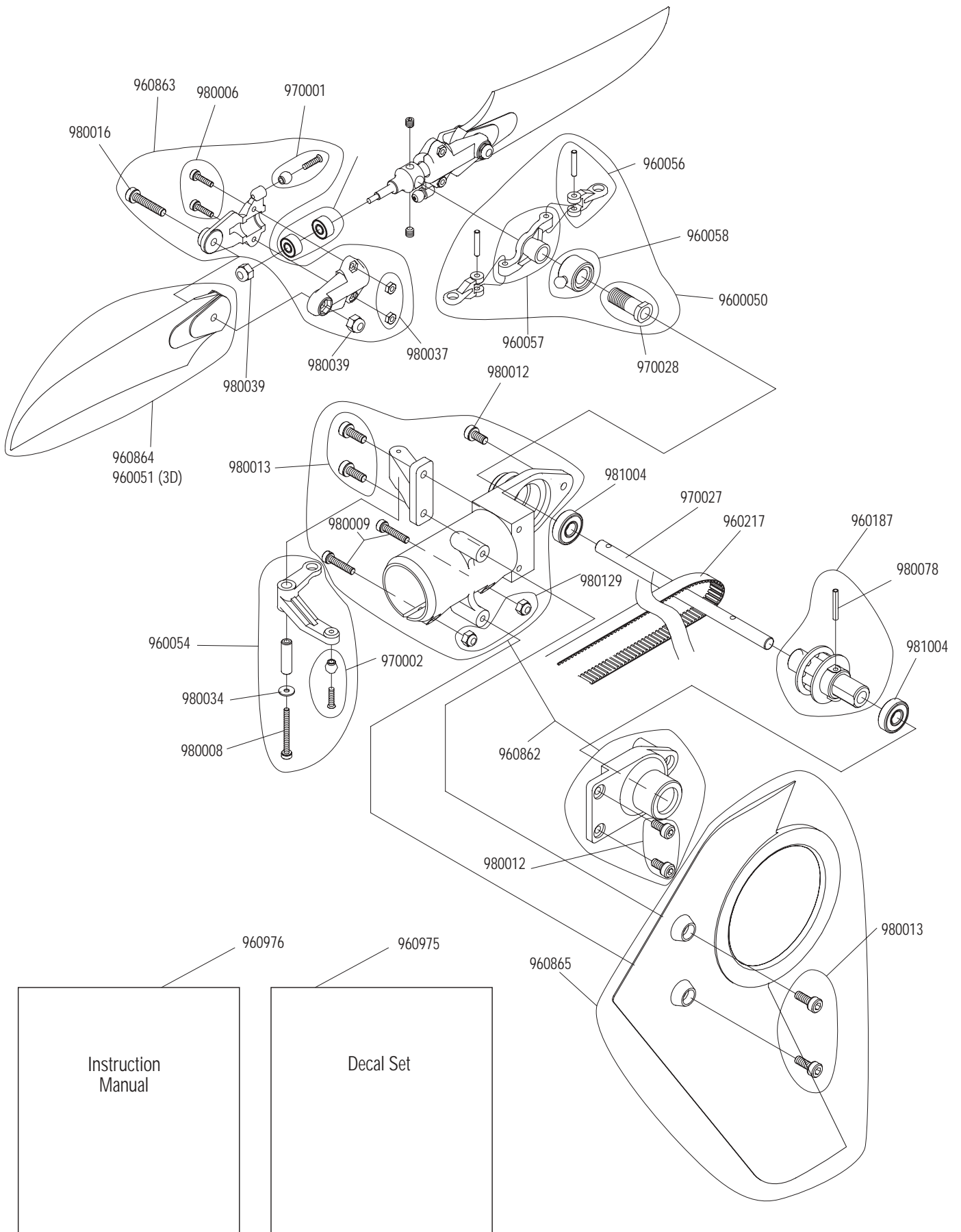

TAIL CASE/TAIL ROTOR ASSEMBLY PARTS

PART #	DESCRIPTION	COMMENTS/ADDITIONAL CONTENTS	QUANTITY
JRP960217	Long Tail Drive Belt	Long Tail Drive Belt	1
JRP960862	Tail Case	Tail Case R Tail Case L Tail Pitch Base 3x8 mm Socket Head Bolt 3x6 mm Socket Head Bolt 2.6x12 mm Socket Head Bolt 2.6 mm Lock Nut	1 1 1 2 3 2 2
JRP981004	Ball Bearing 5x13x4 mm (R-1350ZZ)	Ball Bearing 5x13x4 mm (R-1350ZZ)	2
JRP980012	3x6 mm Socket Head Bolt	3x6 mm Socket Head Bolt	10
JRP970027	Tail Output Shaft	Tail Output Shaft	1
JRP960187	Tail Belt Pulley	Tail Belt Pulley Spring Pin 2x13 mm	1 1
JRP970001	Steel Joint Ball A	Steel Joint Ball Flat Head Screw 2x8 mm	10 10
JRP980037	2 mm Hex Nut	2 mm Hex Nut	10
JRP980078	Spring Pin 2x13 mm	Spring Pin 2x13 mm	5
JRP960222	Tail Center Hub B	Tail Center Hub B 3x3 mm Set Screw 3 mm Lock Nut	1 2 2
JRP981022	Ball Bearing 3x8x4 mm (R-830ZZ)	Ball Bearing 3x8x4 mm (R-830ZZ)	2
JRP960863	Tail Blade Holder Set	Tail Blade Holder Set w/Ball Base Tail Blade Holder Set w/o Ball Steel Joint Ball Flat Head Screw 2x8 mm 2x8 mm Socket Head Bolt 2 mm Hex Nut 3x15 mm Socket Head Bolt 3 mm Lock Nut	2 2 2 2 4 4 2 2
JRP960864	Tail Rotor Blade	Tail Rotor Blade	2
JRP960054	Tail Pitch Control Lever	Tail Pitch Control Lever Tail Pitch Lever Bushing 2x20 mm Socket Head Bolt 2 mm Flat Washer Steel Joint Ball Flat Head Screw 2x8 mm Vertical Fin 3x8 mm Socket Head Bolt 3x10 mm Socket Head Bolt 3 mm Lock Nut	1 1 1 1 1 1 1 2 2 2
JRP980067	3x3 mm Set Screw	3x3 mm Set Screw	10
JRP980089	2.6x10 mm Socket Head Bolt	2.6x10 mm Socket Head Bolt	10
JRP960057	Tail Pitch Plate	Tail Pitch Control Plate	1
JRP981049	Ball Bearing 3x6x2.5 mm (L-630ZZ)	Ball Bearing 3x6x2.5 mm (L-630ZZ)	2
JRP960056	Tail Pitch Link	Tail Pitch Link Tail Pitch Link Pin CA Stopper Ring 2mm	2 2 4
JRP960050	Tail Slide Ring Assembly	Tail Slide Ring Tail Slide Ring Sleeve Tail Pitch Plate Tail Pitch Link Tail Pitch Link Pin	1 1 1 2 2
JRP980006	Socket Head Bolts, 2x8 mm	Socket Head Bolts, 2x8 mm	10
JRP980016	Socket Head Bolts, 3x15 mm	Socket Head Bolts, 3x15 mm	10
JRP980039	Lock Nuts, 3 mm	Lock Nuts, 3 mm	10
JRP960051	Tail Rotor Blades (3D)	Tail Rotor Blades (3D)	2
JRP980013	Socket Head Bolts, 3x8 mm	Socket Head Bolts, 3x8 mm	10
JRP980008	Socket Head Bolts, 2x20 mm	Socket Head Bolts, 2x20 mm	10
JRP980034	Plate Washers, 2 mm	Plate Washers, 2 mm	10
JRP960058	Tail Slide Ring	Tail Slide Ring	1
JRP970028	Tail Slide Ring Sleeve	Tail Slide Ring Sleeve	1
JRP960975	Venture 50 Decal Set	Decal A	1
JRP960976	Venture 50 Assembly Manual	Assembly Manual	1

