



© 2008 Manufactured exclusively for Horizon Hobby, Inc.
www.evolutionengines.com 877-504-2333

13207

Evolution[®] Engines

152GX

USER GUIDE

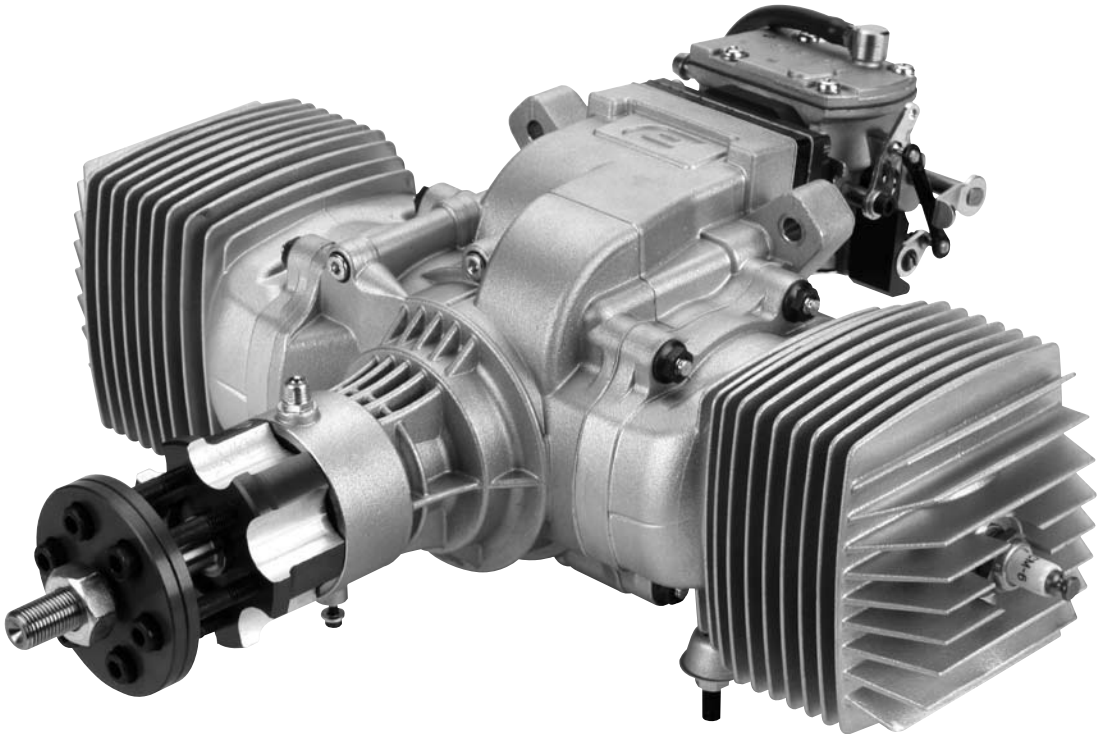

E
EVOLUTION
GAS POWER

Table of Contents

Introduction	3
Contents Included	5
Mounting the Engine	5
Throttle Linkage	5
Choke Actuation	5
Attaching the Fuel Lines	5
Spark Plug	5
Selecting a Suitable Propeller	5
Suggested Propeller Dimensions.....	5
Control Jet System.....	6
Ignition System Warning.....	7
Ignition Unit Power Source.....	7
Warnings	7
Enabling or Disabling Battery Test.....	8
Starting the Engine.....	9
Starting the Engine Continued	10
Carburetor Adjustment	10
Troubleshooting Guide	11
152GX Evolution Engine Dimensions	12
152GX Evolution Engine Specifications	12
Evolution Engines Auto-Choke Ignition System.....	12
Installation of the Auto-Choke Ignition Unit	13
Ignition Unit Wiring.....	14
Programming Auto-Choke Ignition System and Pre-Ignition Curve	14
152GX Parts Diagram.....	15
152GX Parts List	16

Introduction

Congratulations on your purchase of one of the newest and most technically advanced 2-stroke gas model airplane engines in the world. Whether you are new to the sport of model aviation or an experienced pilot, you will enjoy the features of the new Evolution® GX engine. Evolution engines are designed to be the most powerful in their class, extremely easy to start and operate, and provide years of enjoyable service. This user's guide is intended to provide the basic information required to operate and maintain your Evolution GX engine.

Important: *While the Evolution engine is extremely easy to operate, if this is your first experience flying a model airplane, it is highly recommended that you have the help of an experienced modeler during the first few flights. Your local hobby store or flying club can put you in touch with an experienced pilot in your area.*

Warranty Period

Exclusive Warranty- Horizon Hobby, Inc., (Horizon) warrants that the Products purchased (the "Product") will be free from defects in materials and workmanship for a period of 2 years from the date of purchase by the Purchaser.

Limited Warranty

(a) This warranty is limited to the original Purchaser ("Purchaser") and is not transferable. REPAIR OR REPLACEMENT AS PROVIDED UNDER THIS WARRANTY IS THE EXCLUSIVE REMEDY OF THE PURCHASER. This warranty covers only those Products purchased from an authorized Horizon dealer. Third party transactions are not covered by this warranty. Proof of purchase is required for warranty claims. Further, Horizon reserves the right to change or modify this warranty without notice and disclaims all other warranties, express or implied.

(b) Limitations- HORIZON MAKES NO WARRANTY OR REPRESENTATION, EXPRESS OR IMPLIED, ABOUT NON-INFRINGEMENT, MERCHANTABILITY OR FITNESS FOR A PARTICULAR PURPOSE OF THE PRODUCT. THE PURCHASER ACKNOWLEDGES THAT THEY ALONE HAVE DETERMINED THAT THE PRODUCT WILL SUITABLY MEET THE REQUIREMENTS OF THE PURCHASER'S INTENDED USE.

(c) Purchaser Remedy- Horizon's sole obligation hereunder shall be that Horizon will, at its option, (i) repair or (ii) replace, any Product determined by Horizon to be defective. In the event of a defect, these are the Purchaser's exclusive remedies. Horizon reserves the right to inspect any and all equipment involved in a warranty claim. Repair or replacement decisions are at the sole discretion of Horizon. This warranty does not cover cosmetic damage or damage due to acts of God, accident, misuse, abuse, negligence, commercial use, or modification of or to any part of the Product. This warranty does not cover damage due to improper installation, operation, maintenance, or attempted repair by anyone other than Horizon. Return of any goods by Purchaser must be approved in writing by Horizon before shipment.

Damage Limits

HORIZON SHALL NOT BE LIABLE FOR SPECIAL, INDIRECT OR CONSEQUENTIAL DAMAGES, LOSS OF PROFITS OR PRODUCTION OR COMMERCIAL LOSS IN ANY WAY CONNECTED WITH THE PRODUCT, WHETHER SUCH CLAIM IS BASED IN CONTRACT, WARRANTY, NEGLIGENCE, OR STRICT LIABILITY. Further, in no event shall the liability of Horizon exceed the individual price of the Product on which liability is asserted. As Horizon has no control over use, setup, final assembly, modification or misuse, no liability shall be assumed nor accepted for any resulting damage or injury. By the act of use, setup or assembly, the user accepts all resulting liability. If you as the Purchaser or user are not prepared to accept the liability associated with the use of this Product, you are advised to return this Product immediately in new and unused condition to the place of purchase.

LAW: These Terms are governed by Illinois law (without regard to conflict of law principals).

Safety Precautions

This is a sophisticated hobby Product and not a toy. It must be operated with caution and common sense and requires some basic mechanical ability. Failure to operate this Product in a safe and responsible manner could result in injury or damage to the Product or other property. This Product is not intended for use by children without direct adult supervision. The Product manual contains instructions for safety, operation and maintenance. It is essential to read and follow all the instructions and warnings in the manual, prior to assembly, setup or use, in order to operate correctly and avoid damage or injury.

Questions, Assistance, and Repairs

Your local hobby store and/or place of purchase cannot provide warranty support or repair. Once assembly, setup or use of the Product has been started, you must contact Horizon directly. This will enable Horizon to better answer your questions and service you in the event that you may need any assistance. For questions or assistance, please direct your email to productsupport@horizonhobby.com, or call 877.504.0233 toll free to speak to a service technician.

Inspection or Repairs

If this Product needs to be inspected or repaired, please call for a Return Merchandise Authorization (RMA). Pack the Product securely using a shipping carton. Please note that original boxes may be included, but are not designed to withstand the rigors of shipping without additional protection. Ship via a carrier that provides tracking and insurance for lost or damaged parcels, as Horizon is not responsible for merchandise until it arrives and is accepted at our facility. A Service Repair Request is available at www.horizonhobby.com on the "Support" tab. If you do not have internet access, please include a letter with your complete name, street address, email address and phone number where you can be reached during business days, your RMA number, a list of the included items, method of payment for any non-warranty expenses and a brief summary of the problem. Your original sales receipt must also be included for warranty consideration. Be sure your name, address, and RMA number are clearly written on the outside of the shipping carton.

Warranty Inspection and Repairs

TO RECEIVE WARRANTY SERVICE, YOU MUST INCLUDE YOUR ORIGINAL SALES RECEIPT verifying the proof-of-purchase date. Provided warranty conditions have been met, your Product will be repaired or replaced free of charge. Repair or replacement decisions are at the sole discretion of Horizon Hobby.

Non-Warranty Repairs

Should your repair not be covered by warranty, the repair will be completed and payment will be required without notification or estimate of the expense unless the expense exceeds 50% of the retail purchase cost. By submitting the item for repair you are agreeing to payment of the repair without notification. Repair estimates are available upon request. You must include this request with your repair. Non-warranty repair estimates will be billed a minimum of ½ hour of labor. In addition you will be billed for return freight. Please advise us of your preferred method of payment. Horizon accepts money orders and cashiers checks, as well as Visa, MasterCard, American Express, and Discover cards. If you choose to pay by credit card, please include your credit card number and expiration date. Any repair left unpaid or unclaimed after 90 days will be considered abandoned and will be disposed of accordingly. **Please note: non-warranty repair is only available on electronics and model engines.**

United States:

Electronics and engines requiring inspection or repair should be shipped to the following address:

**Horizon Service Center
4105 Fieldstone Road
Champaign, Illinois 61822**

All other Products requiring warranty inspection or repair should be shipped to the following address:

**Horizon Product Support
4105 Fieldstone Road
Champaign, Illinois 61822**

Please call 877-504-0233 or e-mail us at productsupport@horizonhobby.com with any questions or concerns regarding this product or warranty.

United Kingdom:

Electronics and engines requiring inspection or repair should be shipped to the following address:

**Horizon Hobby UK
Units 1-4 Ployters Rd
Staple Tye
Harlow, Essex
CM18 7NS
United Kingdom**

Please call +44 (0) 1279 641 097 or e-mail us at sales@horizonhobby.co.uk with any questions or concerns regarding this product or warranty.

Germany:

Electronics and engines requiring inspection or repair should be shipped to the following address:

**Horizon Technischer Service
Hamburger Strasse 10
25335 Elmshorn
Germany**

Please call +49 4121 46199 66 or e-mail us at service@horizonhobby.de with any questions or concerns regarding this product or warranty.

Contents Included

Engine

Spark Plug 2 pcs (EVO30013309)

Electronic Ignition (EVO3314BB)

Exhaust Gasket (EVO30070407)

Plug wrench

Spark plug cable spiral wrap

Break in oil

Instruction sheet

Decal sheet

Optional Items

Muffler (EVO30113410)

Gas Start Kit (EVO1002)

Evolution 2-cycle Synthetic Oil (EVOX1001Q)

Silencer system (EVO30114210E)

Evolution stand off all 116/152 (EVO3312)

Ignition battery 3-cell 2100mAh Li-Po (THP21003SPL)

Micro Digital Tachometer (HAN156)

Mounting the Engine

Most model airplane designs make provision for an engine mount. It is extremely important that the engine mount be securely attached to the airplane's firewall and that the engine is securely attached to the engine mount. Follow the instructions included with the airplane for mounting the engine. The engine should be fastened in place to the firewall with 4 screws. Use good quality 1/4-inch or 6mm screw, blind nuts and lock washers. Position the throttle servo, lower than the carburetor, to allow for more linear movement of the throttle. If you decide to fasten the engine using a flexible motor mount, always choose parts with enough solidity and strength. Make sure all screws are tightened and regularly check that they remain tight and in good condition.

In most installations an engine standoff will be required. To install the entire engine forward of the firewall, one minimum 3-inch standoff is needed. We recommend the EVO3312 engine standoff assembly (available separately).

Important: *Air is necessary to cool the engine during operation. Make sure that sufficient air circulation through the cowling is provided. As a basic reference, the outlet area should be 3–5 times the area of the inlet area to provide adequate cooling.*

Throttle Linkage

Carefully attach the throttle linkage to the engine using a ball link on the carburetor. The throttle arm will accommodate a 4/40 ball link. Make sure that the linkage is free to operate from low throttle

to high throttle and confirm that the low throttle setting on the transmitter closes the carburetor butterfly to the low idle position. Adjust the length of the pushrod until full throttle opens the throttle fully, while low-throttle (low trim) completely closes the butterfly.

Choke Actuation

The choke lever is not drilled to accommodate a linkage from the factory. If you plan to use a servo to activate the choke, the lever will need to be drilled. Set this up in a manner similar to the throttle linkage.

Attaching the Fuel Lines

Use large gasoline-compatible fuel line in the fuel tank as well as the supply line to the engine. Use 3/16 brass/copper fuel tubing to plumb the fuel tank. Be sure that the clunk inlet hole is of sufficient size to work with this size of large fuel tubing.

Fuel for the Evolution Gas Engine

The Evolution gas engine has been designed to run on a mixture of high-quality 91 octane unleaded gasoline and synthetic oil intended for racing 2-stroke gasoline engines. For the break-in period of the new engine, mix the fuel in a ratio of 30 parts gasoline to 1 part lubricant. After break-in, use a ratio of 40 parts gasoline to 1 part lubricant.



Spark Plug

The Evolution 152GX engine uses a CM-6 type of spark plug. Before installing the spark plug you will need to set the spark plug gap to the following dimension: .024 in to .028 in (.6mm to .7mm).

Selecting a Suitable Propeller

The Evolution® 152GX has been designed to generate maximum power at 5800–6300 rpm, according to the type of exhaust used. If you wish to utilize the maximum power output, choose a propeller, which will allow the engine to reach these revolutions, or slightly lower revolutions. (The engine will unload in the air, depending on the aircraft speed and propeller selected.)

Suggested Propeller Dimensions

152GX	Two-blade	30x10	30x12	32x10	32x12	32.5x11
	Three-blade	28.5x12	29x12			

We do not recommend using propellers that allow the engine to reach more than 7500 rpm on the ground.

Control Jet System

Your engine is equipped with a unique system enabling improved acceleration from idle to high speed. This system allows the mixture to be controlled while the throttle valve is opening. It will lean the mixture at low rpm and at idle. Conversely the mixture will become richer as the throttle is opening. This system provides better acceleration to high speed and maintains a stable idle.

This system was developed for the Evolution 152cc engine. It is recommended that you do not change the mixture control leverage.

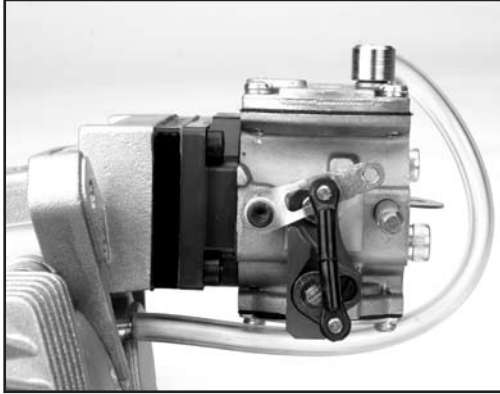

Idle

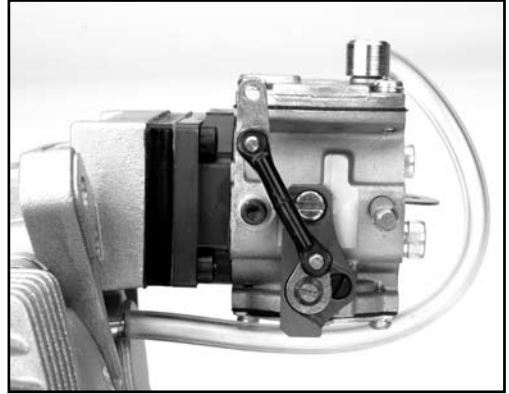

High Throttle

Ignition System Warning

The GX electronic ignition fires the spark plugs for 1 second to check the condition of the battery prior to starting the engine. If the engine is in the compression position (i.e., the piston is above the exhaust port in either the up OR down part of the stroke), any compressed fumes may ignite, causing the propeller to turn and possibly the engine to start unintentionally.

To prevent this with the Evolution Gasoline GX Ignition System, the Ignition Power Switch must be turned off; check to see that the piston is in the bottom dead center (BDC) position.

Bottom Dead Center can be found by rotating the propeller through the compression stroke. As you rotate the propeller you will feel it tighten, then suddenly loosen. Once the turn becomes very easy you have completed the compression stroke and are at BDC. Once you are sure the piston is in this position, you may turn on the ignition power switch and operate the system safely.

As always, it is important to use extreme caution when near or working with engines, fuel and propellers. If you have any questions or concerns, please contact the Horizon Support Team at 1-877-504-0233 or productsupport@horizonhobby.com.

Ignition Unit Power Source

The Evolution 152GX ignition system was designed around a 3S 11.1-volt Li-Po battery pack. The system will operate from a minimum of 9 volts to a maximum of 13 volts. In the event that the engine is in an inactive state for 90 seconds, the ignition unit goes into Fail-safe and automatically turns off the ignition battery source. In order to power the ignition system back up, cycle the ignition power switch from Off to On.

Warnings

Always do a range check with the engine running before the first flight. Use the ignition only in dry conditions. Use recommended number and type of cells for each ignition type. This product is specified for RC engines only. Do not remove the resistor cover if the ignition is on.

WARNING: REVERSAL OF POLES ON WIRE TO BATTERY WILL DESTROY THE IGNITION.

WARNING: DANGER OF ELECTRIC SHOCK (VOLTAGE OVER 20,000V).

WARNING: The manufacturer is not responsible for damages caused by not following the manual and/or use with anything other than RC engines.

WARNING: Because of possible interference, ignition and accumulators should be placed at least 25 cm from the receiver.

CAUTION: Use a standard servo with a current draw of less than 1.5A to operate the choke. Servos with a current draw greater than 1.5A, such as micro servos, digital servos and high-torque servos, consume more current than the ignition system's circuitry is designed to provide. If the servo you've connected quivers or won't work at all, its current draw is probably too high.

Enabling or Disabling Battery Test

This ignition makes it possible to enable or disable the battery test. The battery test is very useful when Li-Po or Li-Ion batteries are used. During the test, a series of flashes are generated and voltage is measured. When the battery passes the test, that means it will run for a minimum of 10 minutes in flight.

- Battery test is disabled when jumper is removed and programming pins are open (this is the default condition of the engine as shipped from Evolution)

- Battery test is enabled when jumper is plugged in and programming pins are closed

WARNING: *The ignition system performs a self test when turning on the ignitions switch. During the self test the spark plugs are energized for a single spark. DO NOT HAVE THE ENGINE POSITIONED ON COMPRESSION STROKE WHEN TURNING ON THE IGNITION SWITCH. It is possible for combustion to occur and the prop to start rotating when turning the ignition switch on. Be sure to restrain the aircraft prior to turning the ignition on when using the battery test feature.*

- Enable or disable battery test when the ignition is off

If you want to change the type of silencer, do the first two steps and then continue to PROGRAMMING SEQUENCE. Otherwise, follow these steps:

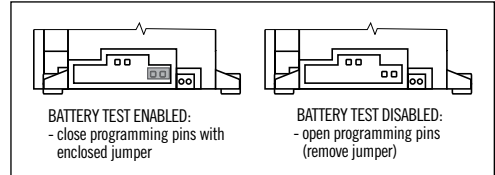

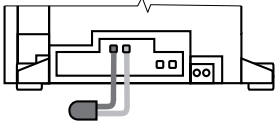
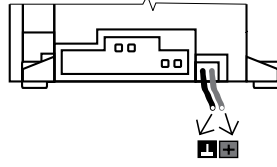
FIRST STEP	SECOND STEP	START
<ul style="list-style-type: none">- Screw pickup on engine- Attach the plastic protection to the high-voltage cable- Connect boot to plug- Mount ground terminal on the high-voltage cable bolt holding the engine to the motor mount- Mount the ignition to the airplane	<ul style="list-style-type: none">- Connect enclosed LED to the ignition (red or red/black wire to left) 	<ul style="list-style-type: none">- Keep clear of the propeller- Connect battery with the ignition box 

Starting Sequence

- Move propeller to put the piston at bottom dead center of its travel
- Keep your hands outside of the propeller radius to avoid serious injury
- Hold the airplane and switch on ignition
- If battery test is enabled, the ignition starts battery test; during this test, a series of sparks are generated for about 2 seconds and LED is blinking
- If battery test is disabled, then LED blinks for about 2 seconds
- If LED turns off, you can fly; otherwise battery is low

Starting the Engine

Starting the engine by using your hand or fingers can lead to a serious injury. We recommend that you use a rubber stick to start the engine.

The new Evolution Engine carburetor comes adjusted to a basic setting. This setting should be maintained during the initial break-in runs.

Before you first start the engine, make sure that the spark plug is screwed in and tightened and that the plug socket is fitted in place and fastened down properly. Fix the ignition sensor in the proper position above the magnet with the screws enclosed. Follow the directions in the Ignition System addendum on page 8 to mount the ignition module in your model.

Important: *Never turn the engine over with the ignition turned on unless the spark plug is inserted in the plug socket. This could lead to ignition damage.*

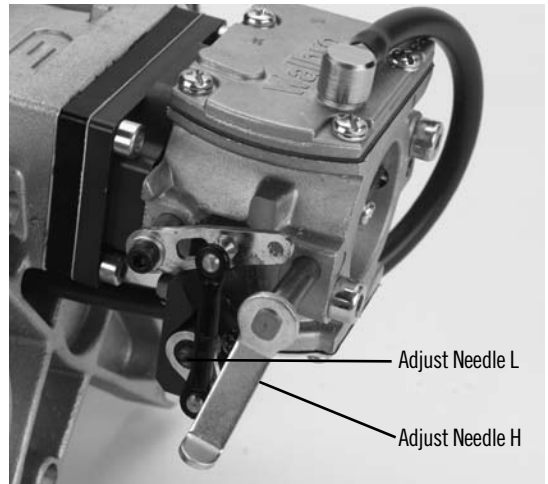

Basic Setting - Throttle Closed

Carburetor Adjustments 152GX

Basic initial settings:

Adjust needle (L) for low rpm range 50 minutes

Adjust needle (H) for high rpm 1 turn

NOTE: The Low Speed adjustment is to the left of the high speed needle.

Starting and Choke Valve Operation

- 1) When you are ready to start your engine, make sure that the ignition is switched off, the choke valve is closed and the throttle valve is partly open. Confirm that fuel is filling the fuel line to the carburetor, then switch the ignition to the ON position. Flip the propeller smartly until the engine fires. With the choke in the closed position, the engine will fire then quit.
- 2) Open the choke valve and set the throttle at a slightly high idle position. Be sure to have a helper hold the model securely. Give the propeller a few quick flips. When the engine starts, allow it to idle for 30 to 45 seconds in order for it to warm up to operating temperature. At this point, you can proceed to test the carburetor settings before flying your model. See the following section regarding carburetor adjustment.
- 3) If the engine does not start, leave the throttle at the high idle position, turn the ignition off, then on and close the choke valve. Start the engine with the throttle at the fast idle position and the choke valve closed. The engine should fire and quit. If it does, repeat step 2 above.
- 4) At this point, if the engine still will not start, unscrew the spark plugs and check the contacts. Clean any possible excess fuel (an indication of engine flooding) and screw them in again. Further starting should only be done with the throttle at idle position and the choke in the open position. If the plug is dry, then probably not enough fuel has been drawn into the carburetor. If that is the case, check for proper fuel feed and then return to the instructions given in paragraph 1.

Starting the Engine *Continued*

Having started the engine, leave it running for about 5 minutes at a higher idle speed. Then run it for about 20 minutes, while changing revolutions from idle to 1/2–3/4 of the range and shortly holding each position—gradually prolonging the holding periods. After 10 minutes of operation, open the throttle to maximum for a period of about one minute. At this point, stop the engine and let it cool down. Then restart it and check the adjustment. If everything is all right, you can make your first flight. During the first few flights, do not overload the engine and do not let it run at high revolutions for long periods of time (very important during hot weather). Use up all the fuel that was mixed with the oil that is included with your engine. From then on, fuel and oil should be mixed in the proportion 40:1.

Carburetor Adjustment

First, start and warm the engine for 30 to 45 seconds before attempting to adjust the carburetor. In order to confirm that your engine is properly adjusted you should follow the procedure below.

1) Move the throttle from idle to 2/3 of the full throttle position quickly (fast acceleration). Then repeat three times – if the engine accelerates smoothly, go to step 3 below. If acceleration is not smooth, go on to step 2.

2) Faulty acceleration and a tendency to quit is usually attributable to a poor fuel mixture in the medium rpm range. Stop the engine and recheck the fuel feed (the fuel line must not be pinched or broken). Restart the engine and test acceleration again. If the problem persists, adjust the carburetor. Open the low speed needle by 1/8 turn and retest. If acceleration is smooth, open the needle by another 1/8 turn—this should be done because the needle was previously set too lean; if atmospheric conditions have changed recently you may have to readjust the needle. If the engine continues to not accelerate properly, open the low speed needle by 10 minutes. If the engine's operation does not improve, shut it off and check the basic setting, restart the engine and test the acceleration. If the engine runs correctly, go to step 3. If it continues to not accelerate properly, open the low speed needle by another 10 minutes. If acceleration is faulty, the defect is likely to lie somewhere other than an incorrect adjustment.

3) If the engine accelerates correctly, according to the above test, set it at idle speed and accelerate to full speed. Repeat twice more. If the engine functions correctly, go to step 4. If it cuts out, open the low speed needle by another 1/8 turn.

4) If the engine reacts correctly, set it at full speed. If revolutions do not drop, the engine has been adjusted successfully. If revolutions seem to drop, open the high-speed needle by approximately 5 to 10 minutes.

Caution! *The engine must be stopped while you adjust the carburetor in order to prevent injury by the propeller.*

Troubleshooting Guide

If the engine does not start:

- Check and use a new spark plug if needed.
(Check the spark: put the plug into the cable end and by turning the engine you'll see the necessary spark. **Note:** The plug must touch a metal part of the engine.)
- Check fuel lines.
- Check for proper mechanical function by turning the engine over.
- Check that the carburetor is correctly installed.
- Remove the carburetor cover from the feed side; check the filter and blow off carburetor with compressed air (**Caution:** *When using compressed air, use eye protection.*); when re-assembling be careful to maintain the proper order of the components.
- Check the vacuum feed line.

Mechanical Faults

If the engine cannot be turned over easily:

- The piston in the cylinder may be seized: loosen and unscrew the cylinder bolts.
- Carefully remove the cylinder.
- Visually examine the piston and crankcase to find the likely cause of the engine's mechanical problem.

NOTE: *Mechanical repairs must always be completed by our professional service department.*

Replacing the reed valve:

- Loosen carb screws and remove the carburetor (be careful to not damage the gasket).
- Loosen four M4 screws on the flange, remove the flange and take off the reed valve (be careful to not damage the gasket).
- Loosen four M2 screws and remove the old valves, replace them with new ones, replace all screws and tighten gently.
- Be sure the gaskets are in their proper places.

152GX Evolution Engine Dimensions

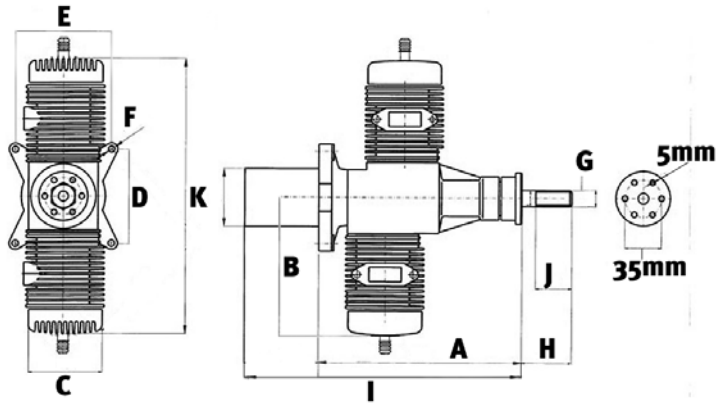

A	B	C	D	E	
170mm	140mm	75mm	90mm	90mm	
F	G	H	I	J	K
6.6mm	M10x1	55mm	234mm	25mm	288mm

152GX Evolution Engine Specifications

Bore	48mm		
Stroke	42mm		
Displacement	152cc / 9.3 cu in	Fuel	Unleaded 91-octane
Weight without ignition*	3530 g / 7.8lb	Lubrication / Break in	Oil with gasoline in mixture 1:30
Weight of ignition unit	210 g / 7.4 oz	Lubrication / Standard	Oil with gasoline in mixture 1:40
RPM range	1000–7500 rpm		

* The value in the table above stands for the weight of a completely assembled engine, including the spark plug, carburetor, drive washer and prop screws.





Evolution Engines Auto-Choke Ignition System

The spark ignition included with your Evolution gas engine is a modern generation electronic ignition. There are many useful functions built into the microprocessor of this unit.

In addition to the basic ignition functions, the unit has a FAIL-SAFE feature: After 90 seconds of inactivity, it automatically switches to an inactive state. In order to restart normal operation, it is necessary to turn the battery switch off and then back on. This function will preserve battery life should the switch be left in the ON position during inactivity.

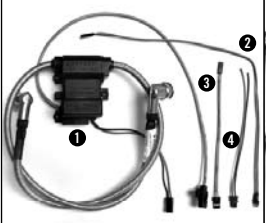
Installation of the Auto-Choke Ignition Unit

While installing the ignition unit in your model, be careful to have all parts that are connected to the unit and the engine situated as far as practical from the radio receiver and radio antenna. The throttle servo should be mounted a distance of 8–12 inches from the engine. The spark plug cable must not touch any part of the model structure as vibration may damage the cable. If this is not practical, it will be necessary to provide an insulation material for the cable. Secure the ignition unit to the airframe using the provided hardware. Install the bolts through the three rubber grommets and tighten securely. The grommets help to dampen the ignition unit from vibration. **DO NOT HARD MOUNT.** Your Evolution ignition module has steel braided spark plug leads with grounding straps. Attach the grounding strap lead to a cylinder base bolt or suitable place on the engine, and push the spark plug cap firmly on the spark plug. Install the spiral wrap spark plug lead covering to protect the plug lead steel braiding from any possible chafing.

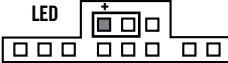
			
<p> 1 Ignition 2 LED 3 Programming cable 4 Power cable </p>	<p>ICU-B</p> <p style="text-align: right;">Min 9V Max 13V</p>	<p>Connect LED indicator to the ignition box (red/black wire to "+").</p>	<p>Using the included connector, plug your battery pack into the ignition box. Five seconds after connecting the battery, the LED indicator should go out. If the LED is blinking after you connect the battery, the battery's voltage is too low.</p>
			

LED Blinking Patterns

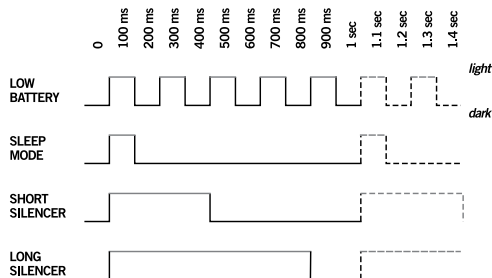

Technical Data

Version	
Weight	210 g
Power supply	3x Li-Ion/Li-Po* 11.1V 9x Ni-Cd / Ni-MH* 9–13V
Minimal battery voltage*	9V*
Maximum battery voltage*	13V*
<i>Sleep mode after 90 seconds of engine inactivity</i>	
<i>Battery level signalization *</i>	
<i>Ignition goes off if engine runs counterclockwise</i>	
Choice of preignition curve	
Preignition point	5°
Location of the magnet	240° / 120°
Min battery capacity	1Ah

* if battery test is enabled

Never use ignition with plug cap removed from plug! Before first flight, do a range check with running engine.

Ignition Unit Wiring

The Evolution 152GX ignition system has an incorporated automatic choke feature. The automatic choke feature will require the installation of a choke servo connected to the choke lever via pushrod. The choke lever is not drilled to accommodate hardware from the factory but it is simple to drill and add a ball link to the lever.

Programming of the automatic choke feature is required through a simple process. Look to the programming chart for the wiring and programming process. There is a slightly different program procedure, depending on what type of exhaust system is installed on the engine. If the automatic choke feature is not desired, omit the ignition programming steps and use a manual choke mechanism. The ignition programming LED can still be used as an onboard ignition battery pack status light.

Programming Auto-Choke Ignition System and Pre-Ignition Curve

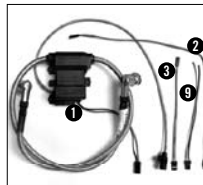
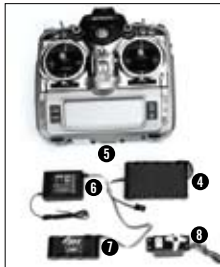

- 1 Ignition
- 2 LED
- 3 Programming cable
- 4 Ignition battery (6-cell)
3 cell Li-Po 9 cell Ni-cd or Ni-MH
- 5 Transmitter
- 6 Receiver
- 7 Receiver battery
- 8 Servo
- 9 Power cable



Disconnect the ignition system's battery.
Connect the LED indicator.
Connect the throttle potentiometer outlet to the throttle channel on your receiver.

Connect the auto-choke servo to the ignition box (black or brown to "−" pin).
Switch on your transmitter.
Connect receiver battery with the receiver.
Connect ignition battery to the ignition.

Long Silencer Choke Settings (Canister or Tuned Pipe)

- 1) Using the throttle stick, close the choke until it closes completely. Wait until the LED blinks once, indicating the ignition has memorized the "closed choke" position.
- 2) Using the throttle stick, open the choke valve until it is all the way open. Wait until the LED blinks once, indicating the ignition unit has memorized the "choke open" position.
- 3) Leave the choke open for an additional 5 seconds, and the LED will blink rapidly, indicating that the Long Silencer Pre-ignition program has been set.
- 4) Disconnect the receiver.

Short Silencer Choke Settings (Pitts Style)

- 1) Using the throttle stick, close the choke until it closes completely. Wait until the LED blinks once, indicating the ignition has memorized the "closed choke" position.
- 2) Using the throttle stick, open the choke valve until it is all the way open. Wait until the LED blinks once, indicating the ignition unit has memorized the "choke open" position.
- 3) Move the choke to the closed position and hold there for an additional 5 seconds; the LED will blink slowly, indicating that the Short Silencer Pre-ignition program has been set.
- 4) Disconnect the receiver.



152GX Parts Diagram

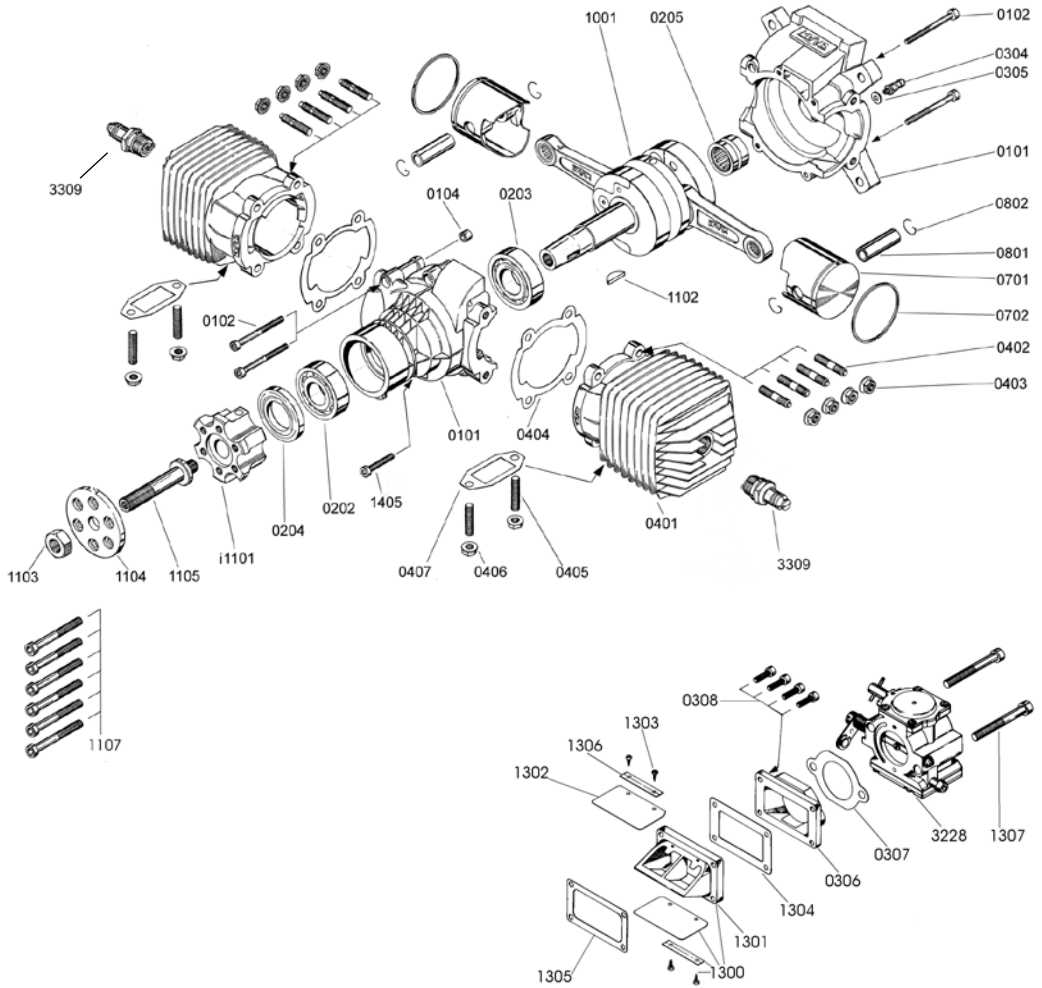

152GX Parts List

Part Number	Description	Part Number	Description
EVO30110101	Crankcase	EVO3010i1101	Drive Washer
EVO30100102	Crankcase Screws Set	EVO30101102	Drive Washer Key
EVO30100104	Spacer Sleeve	EVO30011103	Propeller Nut
EVO30100202	Front Bearing	EVO30101104	Propeller Washer
EVO30070203	Rear Bearing	EVO30101105	Propeller Screw
EVO30100204	Packing	EVO30101107	Propeller Screws Set
EVO30100205	Rear Needle Bearing	EVO30100306	Carburetor Flange
EVO30940304	Pressure Nozzle	EVO30100307	Carburetor Flange Gasket
EVO30940305	Pressure Nozzle Gasket	EVO30010308	Carburetor Flange Screws Set
EVO30110401	Cylinder*	EVO30101301	Reed Valve Case
EVO30010402	Cylinder Screws Set*	EVO30101302	Reed Valve
EVO30010403	Cylinder Nut*	EVO30101303	Reed Valve Screws
EVO30070404	Cylinder Gasket*	EVO30101304	Reed Valve Gasket (Upper)
EVO30010405	Exhaust Screws Set*	EVO30101305	Reed Valve Gasket (Lower)
EVO30010406	Exhaust Nut*	EVO30101306	Reed Valve Strap
EVO30070407	Exhaust Flange Gasket*	EVO30101307	Carburetor Screws
EVO30070701	Piston*	EVO3314BB	Electric Ignition Type 2, ICU-B
EVO30070702	Piston Ring*	EVO30013309	Spark Plug
EVO30070801	Piston Pin*	EVO30941405	Ignition Sensor Fixing Screws
EVO30070802	Piston Pin Retainer*	EVO30101300	Reed Valve Assembly
EVO30111001	Crankshaft Assembly	EVO3228	Carburetor Complete

* Requires a quantity of 2