

Name: _____		Date: _____		Event: _____	
City: _____		State: _____		Track: _____	
Track Conditions	<input type="checkbox"/> Indoor	<input type="checkbox"/> Tight	<input type="checkbox"/> Smooth	<input type="checkbox"/> Hard Packed	<input type="checkbox"/> Blue Groove
	<input type="checkbox"/> Outdoor	<input type="checkbox"/> Open	<input type="checkbox"/> Rough	<input type="checkbox"/> Loose/Loamy	<input type="checkbox"/> Dry
	<input type="checkbox"/> Wet	<input type="checkbox"/> Grass	<input type="checkbox"/> Low Bite	<input type="checkbox"/> High Bite	
	<input type="checkbox"/> Dusty	<input type="checkbox"/> Astro Turf	<input type="checkbox"/> Med Bite	<input type="checkbox"/> Other _____	

Front Suspension

Toe: _____

Ride Height: _____

Camber: _____

Caster: 10° 12.5° 15° 20°

Diff. Type: Ball Gear Setting/Oil: _____

Driveshaft Type: CVA Universal

Front Drive: Full-Time 4WD Clicker: _____

Sway Bar: None White Yellow Pink

Oil: _____

Piston: _____

Spring: Standard Low Freq. Color: _____

Shock Limiters: _____ Stroke: _____

Shock Location: _____

Bump Steer Ball Stud: Standard Low Mount

Bumper Steer Spacers: _____

Camber Link: _____

Ackermann: A B Adjustable: _____

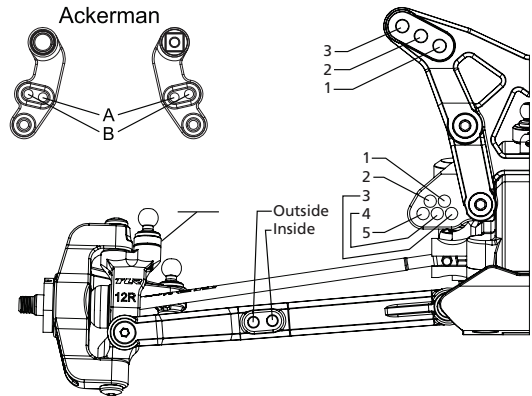

Notes: _____

Rear Suspension

Toe: 2.0° 2.5° 3.0°

Anti-Squat: 1° 2° 2.5° 3°

Roll Center: Low Roll Center (LRC) High Roll Center (HRC)

Ride Height: _____

Camber: _____

Diff. Type: Ball Gear Setting/Oil: _____

Driveshaft Type: CVA Universal

Rear Hub Spacing: _____

Hex Width: _____

Sway Bar: None White Yellow Pink

Oil: _____

Piston: _____

Spring: Standard Low Freq. Color: _____

Shock Limiters: _____ Stroke: _____

Camber Link: _____

Shock Locations: _____

Wing/Wickerbill: _____

Battery Type: Shorty Saddles

Battery Position: _____

Rear Suspension: 22 Hub/Hex 22-4 Hub/Hex

Rear Shock Orientation: Front of Arm Rear of Arm

Electronics

Timing Advance: _____

Radio: _____ Throttle/Brake Expo: _____

Servo: _____ Servo Expo: _____

ESC: _____ Throttle/Brake EPA: _____

Initial Brake: _____ Motor: _____

Drag Brake: _____ Pinion: _____ Spur: _____

Throttle Profile: _____ Battery: _____

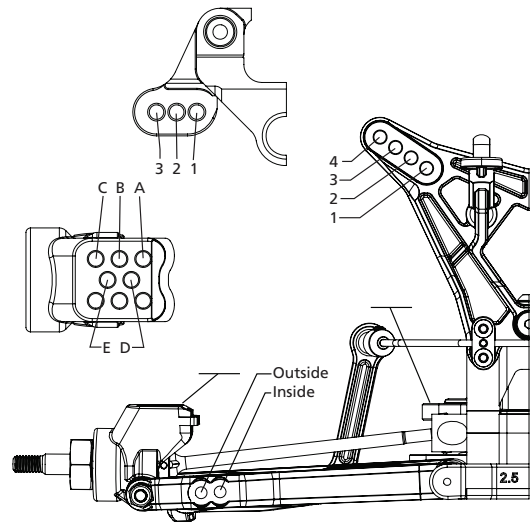

Notes: _____

Tires	Compound	Insert	Additive
Front: _____	_____	_____	_____
Rear: _____	_____	_____	_____