



REVOLUTION®

VIZO™ XL

FPV CAMERA DRONE



RTF
READY-TO-FLY

Instruction Manual
Manuel d'utilisation

NOTICE

All instructions, warranties and other collateral documents are subject to change at the sole discretion of Horizon Hobby, LLC. For up-to-date product literature, visit horizonhobby.com and click on the support tab for this product.

Meaning of Special Language

The following terms are used throughout the product literature to indicate various levels of potential harm when operating this product:

WARNING: Procedures, which if not properly followed, create the probability of property damage, collateral damage, and serious injury OR create a high probability of superficial injury.

CAUTION: Procedures, which if not properly followed, create the probability of physical property damage AND a possibility of serious injury.

NOTICE: Procedures, which if not properly followed, create a possibility of physical property damage AND a little or no possibility of injury.

 **WARNING:** Read the ENTIRE instruction manual to become familiar with the features of the product before operating. Failure to operate the product correctly can result in damage to the product, personal property and cause serious injury.

This is a sophisticated hobby product. It must be operated with caution and common sense and requires some basic mechanical ability. Failure to operate this Product in a safe and responsible manner could result in injury or damage to the product or other property. This product is not intended for use by children without direct adult supervision. Do not use with incompatible components or alter this product in any way outside of the instructions provided by Horizon Hobby, LLC. This manual contains instructions for safety, operation and maintenance. It is essential to read and follow all the instructions and warnings in the manual, prior to assembly, setup or use, in order to operate correctly and avoid damage or serious injury.

Age Recommendation: Not for children under 14 years. This is not a toy.

Safety Precautions and Warnings

- Always keep a safe distance in all directions around your model to avoid collisions or injury. This model is controlled by a radio signal subject to interference from many sources outside your control. Interference can cause momentary loss of control.
- Always operate your model in open spaces away from full-size vehicles, traffic and people.
- Always carefully follow the directions and warnings for this and any optional support equipment (chargers, rechargeable battery packs, etc.).
- Always keep all chemicals, small parts and anything electrical out of the reach of children.
- Always avoid water exposure to all equipment not specifically designed and protected for this purpose. Moisture causes damage to electronics.
- Never place any portion of the model in your mouth as it could cause serious injury or even death.
- Never operate your model with low transmitter batteries.
- Always keep the model in sight and under control.
- Always move the throttle fully down at rotor strike.
- Always use fully charged batteries.
- Always keep transmitter powered on while model is powered.
- Always remove batteries before disassembly.
- Always keep moving parts clean.
- Always keep parts dry.
- Always let parts cool after use before touching.
- Always remove batteries after use.
- Never operate model with damaged wiring.
- Never touch moving parts.

If you are operating this product in North America, you are required to have an Amateur Radio (HAM) license.

Table of Contents

Box Contents	3	360° Flip Mode	8
Transmitter	3	Replacing the Propellers	9
First Flight Preparation	4	Expanding the Transmitter for Smart Device Use	9
Flying Checklist	4	Using the Vizo View App	9
Charging Warnings	4	Camera Use	10
Charging the Flight Battery	4	Troubleshooting Guide	10
Installing the Transmitter Batteries	5	Post-Flight Inspection and Maintenance Checklist	11
Installing the Flight Battery	5	Exploded View	11
Connecting the Drone and Transmitter	5	Parts Listings	11
Understanding the Primary Flight Controls	6	Limited Warranty	12
Flight Rate Selection	6	Warranty and Service Contact Information	13
Flying the Vizo™ XL Camera Drone	7	FCC Statement	13
Calibrating the Drone	7	IC Information	13

Specifications

Length	11.8 in (30cm)	Propeller Length	6.1 in (15.5cm)
Height	2.4 in (6cm)	Flying Weight	6.7 oz (190 g)

Box Contents

- Revolution® Vizo™ XL Camera Drone
- 850mAh 2S 7.4V 25C Li-Po Battery
- USB Li-Po Charger
- Transmitter
- A (2) and B (2) Replacement Propellers
- 4 AAA batteries (for transmitter)

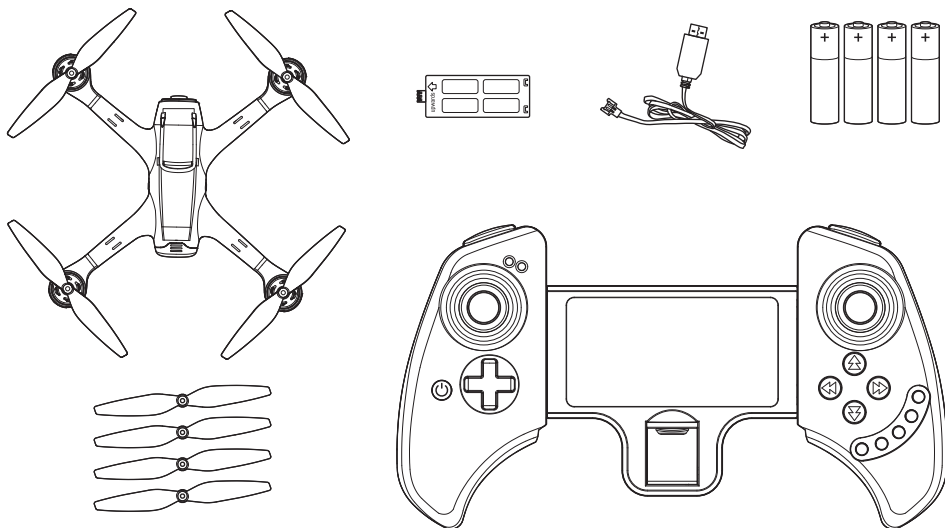

Transmitter

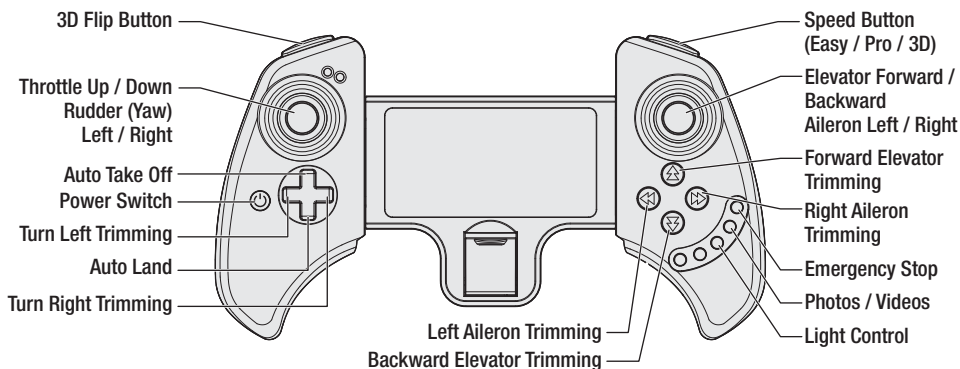

First Flight Preparation

- Remove and inspect the contents
- Charge the flight battery
- Install the batteries in the transmitter
- Familiarize yourself with the controls
- Install the flight battery in the drone (once it is fully charged)
- Connect the transmitter
- Find a suitable flight area for flying

Charging Warnings



CAUTION: All instructions and warnings must be followed exactly. Mishandling of Li-Po batteries can result in a fire, personal injury and/or property damage.

- **NEVER LEAVE CHARGING BATTERIES UNATTENDED.**
- **NEVER CHARGE BATTERIES OVERNIGHT.**
- By handling, charging or using the included Li-Po battery, you assume all risks associated with lithium batteries.
- If at any time the battery begins to balloon or swell, discontinue use immediately. If charging or discharging, discontinue and disconnect. Continuing to use, charge or discharge a battery that is ballooning or swelling can result in fire.
- Always store the battery at room temperature in a dry area for best results.
- Always transport or temporarily store the battery in a temperature range of 40–120° F (5–49° C).
- Do not store battery or model in a car or direct sunlight. If stored in a hot car, the battery can be damaged or even catch fire.

Charging the Flight Battery

NOTICE: Charge only batteries that are cool to the touch and are not damaged. Look at the battery to make sure it is not damaged e.g., swollen, bent, broken or punctured.



CAUTION: Only use chargers specifically designed to charge the included Li-Po battery. Failure to do so could result in fire, causing injury or property damage.



CAUTION: Never exceed the recommended charge rate.

Use only the included USB charger to charge the flight battery.

1. Connect the charger to a suitable USB power port. The charger will work with most 5V mobile power sources or smartphone chargers.

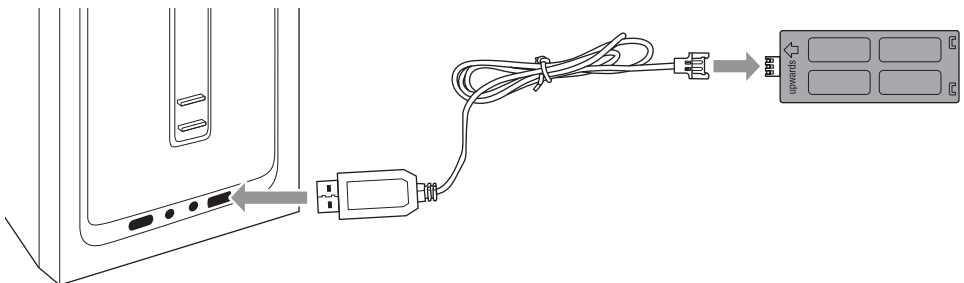

Flying Checklist

- Power on the transmitter
- Plug the flight battery into the drone
- Fly the drone
- Land the drone
- Unplug the flight battery from the drone
- Power off the transmitter

- Always charge batteries away from flammable materials.
- Always inspect the battery before charging
- Always disconnect the battery after charging, and let the charger cool between charges.
- Always constantly monitor the temperature of the battery pack while charging.
- **ONLY USE A CHARGER SPECIFICALLY DESIGNED TO CHARGE LI-PO BATTERIES.** Failure to charge the battery with a compatible charger may cause a fire resulting in personal injury and/or property damage.
- Never discharge Li-Po cells to below 3V under load.
- Never cover warning labels with hook and loop strips.
- Never charge batteries outside recommended levels.
- Never charge damaged batteries.
- Never attempt to dismantle or alter the charger.
- Never allow minors to charge battery packs.
- Never charge batteries in extremely hot or cold places (recommended between 40–120° F or (5–49° C) or place in direct sunlight.

2. Connect the charge lead to the battery, noting correct polarity. Charging a fully discharged flight battery takes approximately 90 minutes. Charge times may vary depending on the power source.
3. Remove the battery from the charger when the charging cycle is complete.
4. Remove the charger from the power supply.



CAUTION: Once charging is complete, immediately remove the battery. Never leave a battery connected to the charger.

Charger LED Indications

RED, solid = Charging

Slow pulse = No battery connected or charging complete

Installing the Transmitter Batteries

To install batteries in the included transmitter:

1. Remove the screws from the battery covers on the back of the transmitter.
2. Install 4 AAA batteries, 2 on each side, noting correct polarity.
3. Replace the battery covers.
4. Replace the screws on the battery covers.

The transmitter will beep intermittently to indicate low battery power.

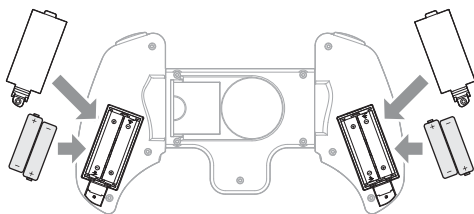

Installing the Flight Battery

1. Open the hatch to the battery compartment.
2. Slide the battery into the back of the drone, as shown, until it is fully seated.

CAUTION: Connecting the battery to the drone power lead with reversed polarity will cause damage to the drone and the battery. Damage caused by incorrectly connecting the battery is not covered under warranty.

CAUTION: Always remove the Li-Po battery from the drone when not flying to avoid over-discharging the battery. Batteries discharged to a voltage lower than the lowest approved voltage may become damaged, resulting in loss of performance and potential fire when batteries are charged.

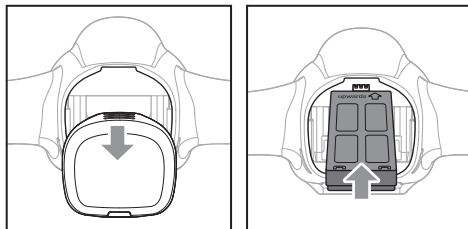

Connecting the Drone and the Transmitter

To connect the drone and transmitter, follow this start up sequence:

1. With the drone on a level surface, power ON the drone by pressing the Power switch for 3 seconds. The drone's LEDs will blink rapidly.
2. Power ON the transmitter by pressing the Power switch for 3 seconds. The transmitter will beep 3 times and the LEDs will be solid.
3. After the beeps, connection is successful. The transmitter's and drone's LEDs stay solid.

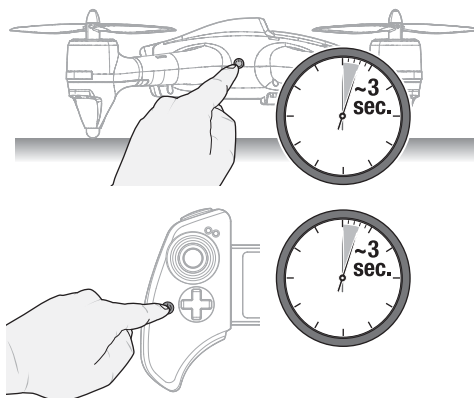

Understanding the Primary Flight Controls

If you are not familiar with the controls of your drone, take a few minutes to familiarize yourself with them before attempting your first flight.

Throttle

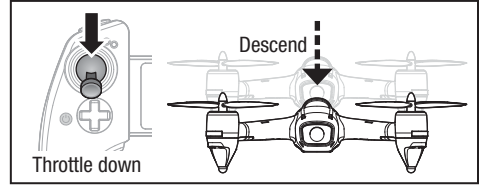
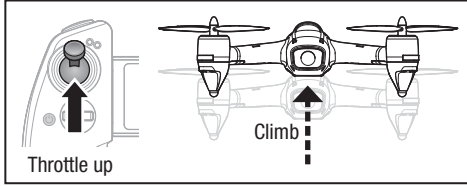

Rudder

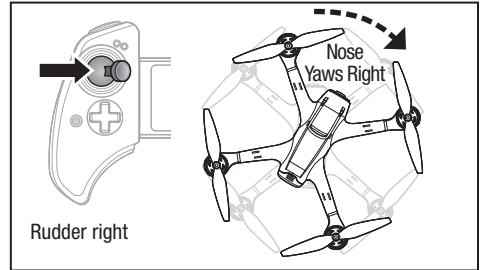
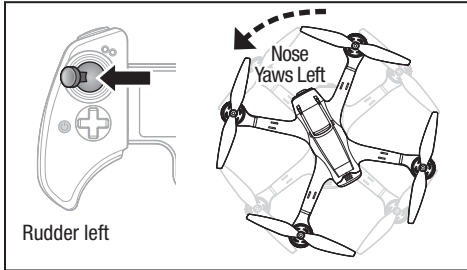

Elevator

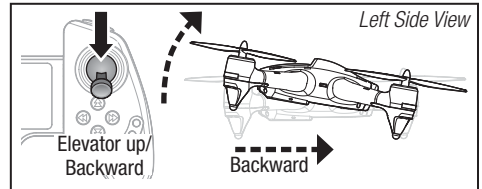
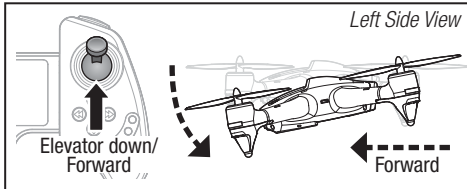

Aileron

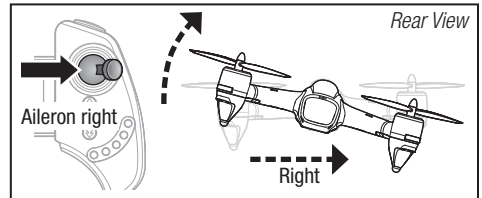
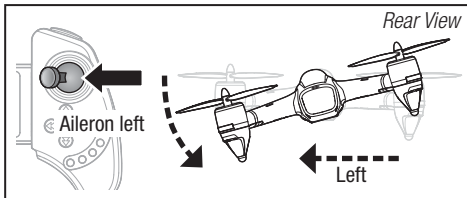

Flight Rate Selection

The Vizo XL camera drone has 3 available flight rates. Press the **Speed** button to cycle through the flight rates from Easy to Pro to 3D. The transmitter beeps, indicating the active flight rate.

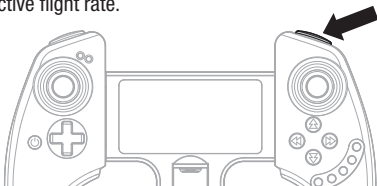

- Easy Rate = 1 beep. This rate limits the possible speed and control sensitivity of the drone. This allows beginner pilots to get used to the flight controls with less chance of over-controlling.
- Pro Rate = 2 beeps. This rate increases the possible flight speed and sensitivity of the drone.
- 3D Rate = 3 beeps. This rate allows for maximum flight speed and maneuverability and is recommended for more experienced pilots.

Flying the Vizo XL Camera Drone

Power on the transmitter and drone, place it on the floor with the nose pointed away from you and step back away from the drone.

IMPORTANT: Beginner pilots should always start with the EASY flight rate.

Takeoff

Press the AUTO TAKE OFF button. –OR–

Push the left and right control sticks to the lower outside corners to arm the throttle then slowly increase the throttle until the drone is approximately 2 ft. (600mm) off the ground. The throttle will not respond until its armed.

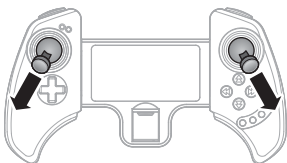

Making small corrections on the transmitter, try to hover the drone in one spot. After moving the right stick and returning it to center the drone should level itself. The drone may continue to move due to inertia. Move the right stick in the opposite direction to stop the movement.

Some minor drifting while hovering is normal due to the movement of air, however, you may use the trim buttons on the transmitter to limit severe drift in any given direction.

If the drone drifts:

- **forward**, use the backward elevator trim button.
- **backward**, use the forward elevator trim button.
- **right**, use the left aileron trim button.
- **left**, use the right aileron trim button.

If the drone rotates (top down view):

- **right**, use the left rudder/yaw button.
- **left**, use the right rudder/yaw button.

Calibrating the Drone

If the drone drifts or is offset in any direction, use these steps to recalibrate the drone:

1. Power ON the transmitter.
2. With the drone on a level surface, power ON the drone.
3. Push the left and right control sticks to the inside corners (as shown) until the navigation light flashes.
4. After calibration is complete, the navigation light stays solid.

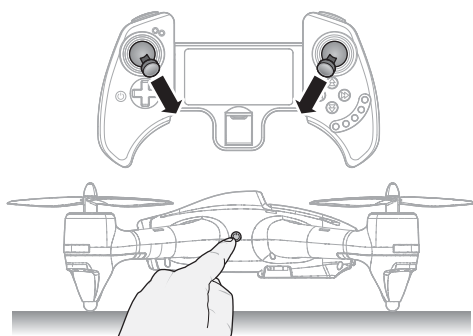

Flying

Maintaining a stable low-level hover, practice using the yaw, pitch and roll controls to familiarize yourself with the drone's responses to control inputs. Remember to keep the control inputs as minimal as possible.

When you are comfortable with basic flight, you can explore the different flight rates and functions explained in the *Flight Rate Selection* section.

Typical flight times for the included battery range from 5–6 minutes.

Low Voltage Cutoff (LVC)

LVC decreases the power to the motors when the battery voltage gets low. The LEDs on the drone will indicate when the battery charge is getting low. When the drone LEDs begin flashing, land the drone immediately and recharge the flight battery. Continuing to fly after the LEDs begin to flash will cause the motors to slow and eventually shut down, causing a crash.

LVC does not prevent the battery from over-discharge during storage.

NOTICE: Crash damage is not covered under warranty.

NOTICE: Repeated flying to LVC will damage the battery.

Landing

To land:

1. Establish a low level hover and slowly decrease the throttle until the drone touches down. Fully decrease the throttle stick to stop the motors. –OR–
2. Press the AUTO LAND button.

Remove the battery from the drone after use to prevent over discharge. During storage, make sure the battery charge does not fall below 3V.

360° Flip Mode

The Vizo XL drone can flip 360° during flight. To perform a flip, press the FLIP button and use the right control stick to give a directional flip command. For optimal results, ensure the drone is at least 5–10 feet (1.5–3 m) off the ground.

Left Flip

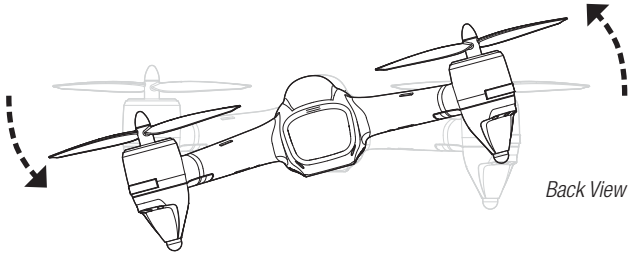
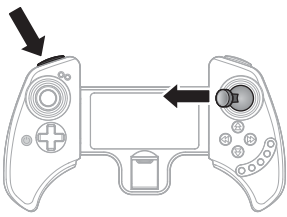

Press the FLIP button. Push the CONTROL stick LEFT then back to center.

Right Flip

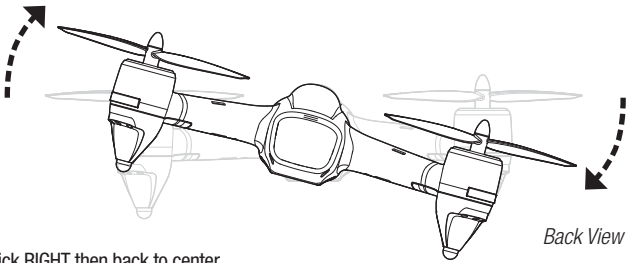
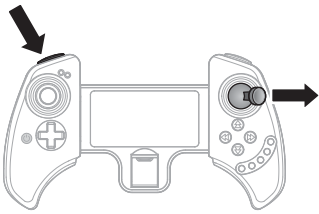

Press the FLIP button. Push the CONTROL stick RIGHT then back to center.

Forward Flip

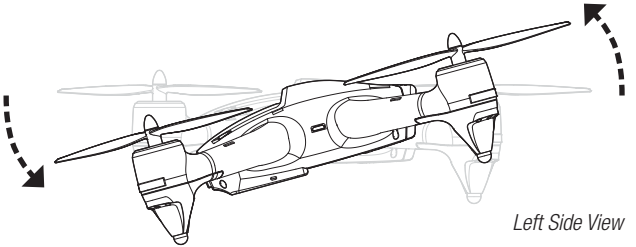
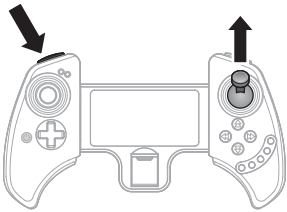

Press the FLIP button. Push the CONTROL stick FORWARD then back to center.

Backward Flip

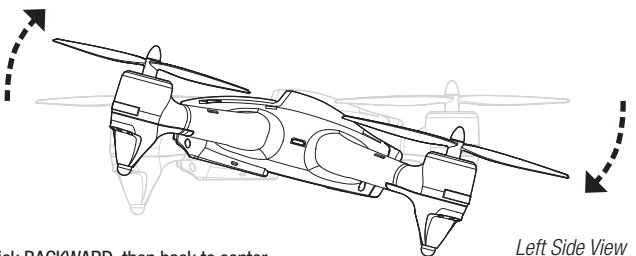
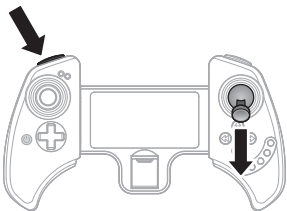

Press the FLIP button. Push the CONTROL stick BACKWARD then back to center.

Replacing the Propellers

The propellers on the Vizo XL drone are marked near the center with an "A" or "B." If a propeller is ever damaged and needs to be replaced, always replace the propeller with the same letter type.

1. Remove the snap-on cap from the propeller hub.
2. Remove the screw holding the propeller in place.
3. Install the new propeller, then replace the screw and cap.

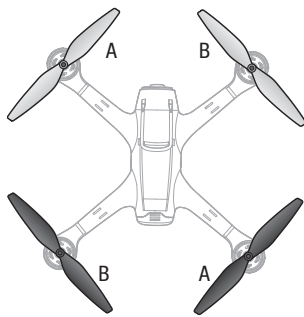
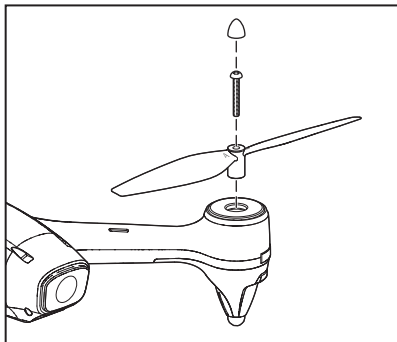

Expanding the Transmitter to Accommodate a Smart Device

1. Pull the stretch lock button on the back of the transmitter to the left.
2. Pull each side to the necessary width to accommodate your desired smart device.

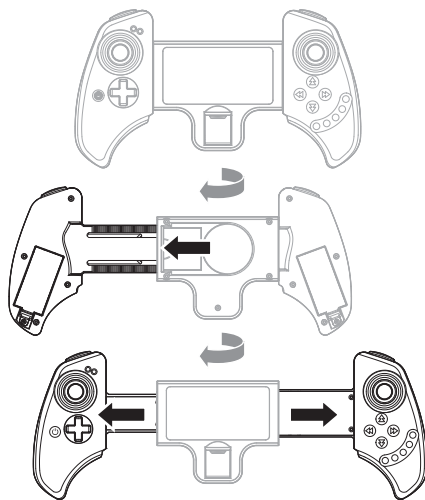

Using the Vizo™ View XL App

The Vizo View XL app is free software for your 2.4GHz WiFi-capable smart device allowing you to:

- connect to the Vizo View camera as FPV
- take videos and pictures
- control the Vizo XL drone using a smart device

1. Install the Vizo View XL app from the Google Play or App Store.
2. Install a micro memory card into the Vizo XL.
3. Connect a fully charged Li-Po battery into the Vizo XL.

NOTICE: When using a smart device to fly FPV, expect latency between the smart device and the drone. Keep your drone within visual range.

NOTICE: The transmitter must stay powered off to completely control your drone via the Vizo View App. The Vizo View on-screen control sticks are disabled when connected to your transmitter.

Camera Use

The Vizo XL drone is equipped with an FPV camera to take pictures and record video via the Vizo View app in real time*. You can save photos/videos to an optional 1–16GB capacity micro memory card or your smart device.

Consult local laws and ordinances before using the camera on this device. You are responsible for operating this product in a legal and responsible manner.

Still Photos

1. Press the PHOTO/VIDEO button on the transmitter.
2. A red LED on the bottom of the drone will flash after each photo is taken.
3. After the LED flashes, the photograph is stored to the micro memory card or your smart device.

Video Recording

1. Hold the PHOTO/VIDEO button for 2 seconds.
2. A red LED on the bottom of the drone will flash, indicating video recording is in progress.
3. Hold the PHOTO/VIDEO button for 2 seconds to stop recording. The drone LED turns solid, indicating that video recording has stopped.

Tip: Press the PHOTO/VIDEO button to take photos while simultaneously recording video.

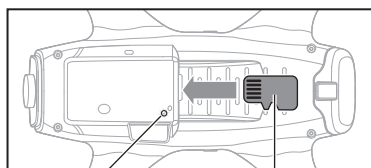

Red LED Optional micro memory card

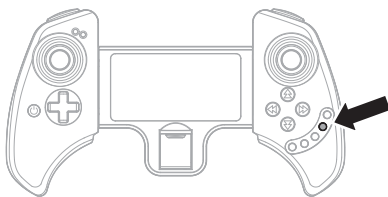

NOTICE: Always insert and remove the micro memory card when the battery is NOT connected to the drone.

*Smart device required. Not included. Download the Vizo View app free from the Google Play or Apple App store.

Troubleshooting Guide

Problem	Possible Cause	Solution
Drone will not respond to throttle	Transmitter incorrectly connected to drone	Cycle power to drone with transmitter ON and perform motor arming procedure
	Flight battery or transmitter battery charge is too low	Replace or recharge batteries
Difficulty connecting transmitter to drone	Drone battery was plugged in before the transmitter was powered ON	Cycle power to drone with the transmitter ON and perform motor arming procedure
	Flight battery or transmitter battery charge is too low	Replace the transmitter batteries or recharge the flight battery
	Drone or transmitter is too close to large metal object, wireless source or another transmitter	Move drone and transmitter to a new location and attempt to connect again
Reduced flight time or reduced power	Flight battery charge is low	Replace or recharge batteries
	Inadequate power to flight battery charger	Use a different power source for the charger
	Flight battery is damaged	Replace the flight battery and follow the flight battery instructions
	Flight conditions too cold	Make sure the battery is warm (room temperature) before use
Crashes immediately upon lift-off	Propellers in wrong locations or interference to propellers	Ensure propeller locations are correct and any interference is clear
	Bent or damaged propeller	Replace bent or damaged propeller
Photos/video will not save	Micro memory card is not formatted	Format the micro memory card
	Micro memory card is full	Use another micro memory card
Photos/video will not save to smart device	App does not have access to the photos/video	Following the app prompts, allow the app to access photos/video
Drone continues to drift	Drone was not level during gyro calibration	Place drone on a level surface. Using paper, shim the drone arm and repeat gyro calibration

Post-Flight Inspection and Maintenance Checklist

✓	
Cleaning	Make sure the battery is not installed before cleaning. Remove dust and debris with a soft brush or a dry, lint-free cloth.
Fasteners	Make sure there are no loose screws, other fasteners or connectors. Do not over-tighten metal screws in plastic parts. Tighten screws so the parts are mated together, then turn the screw only 1/8th of a turn more. Do not use threadlock on or near plastic parts.
Propellers	Make sure there is no damage to the propellers or other parts that move at high speed. Damage to these parts includes cracks, burrs, chips or scratches. Replace damaged parts and remove debris before flying.

Exploded View

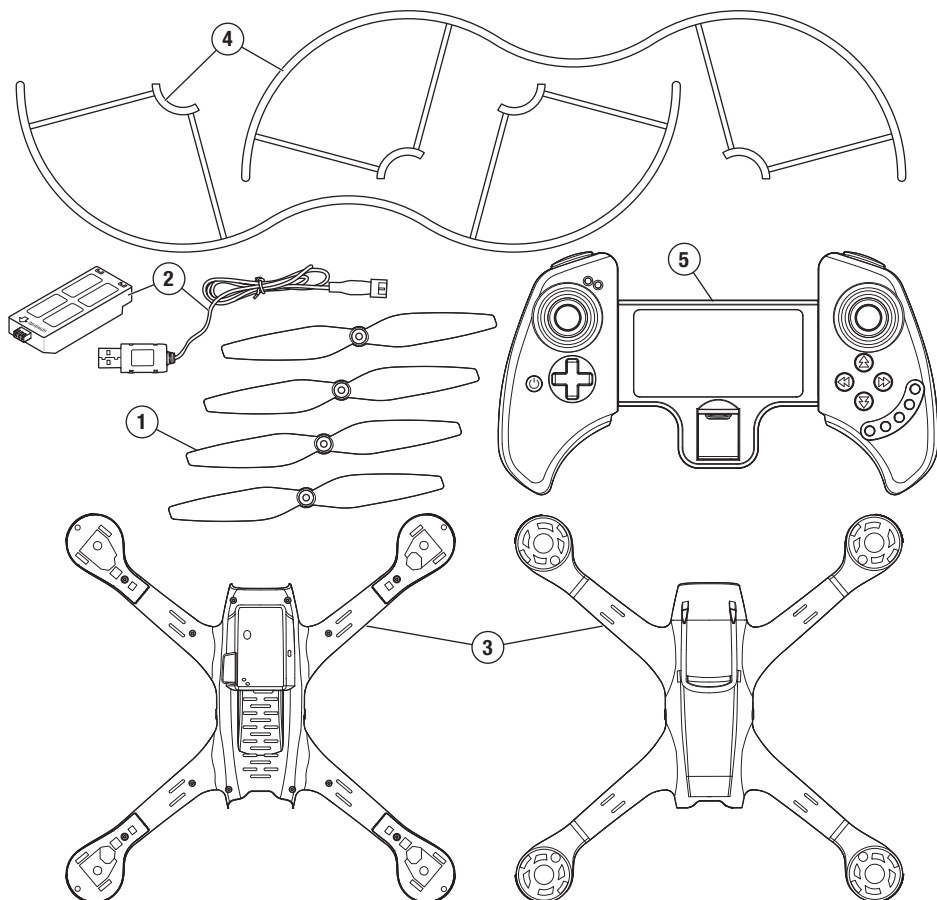

Parts Listings

Part #	Description
1	RVOH1301 Prop Set (4)
2	RVOH1302 850mAh 2S Battery with USB charger
3	RVOH1303 Body Set

Part #	Description
4	RVOH1304 Prop Guard Set (2)
5	RVOH1305 Transmitter
6	RVOH1306 Complete Replacement Air Frame

Limited Warranty

What this Warranty Covers

Horizon Hobby, LLC, (Horizon) warrants to the original purchaser that the product purchased (the "Product") will be free from defects in materials and workmanship at the date of purchase.

What is Not Covered

This warranty is not transferable and does not cover (i) cosmetic damage, (ii) damage due to acts of God, accident, misuse, abuse, negligence, commercial use, or due to improper use, installation, operation or maintenance, (iii) modification of or to any part of the Product, (iv) attempted service by anyone other than a Horizon Hobby authorized service center, (v) Product not purchased from an authorized Horizon dealer, (vi) Product not compliant with applicable technical regulations, or (vii) use that violates any applicable laws, rules, or regulations.

OTHER THAN THE EXPRESS WARRANTY ABOVE, HORIZON MAKES NO OTHER WARRANTY OR REPRESENTATION, AND HEREBY DISCLAIMS ANY AND ALL IMPLIED WARRANTIES, INCLUDING, WITHOUT LIMITATION, THE IMPLIED WARRANTIES OF NON-INFRINGEMENT, MERCHANTABILITY AND FITNESS FOR A PARTICULAR PURPOSE. THE PURCHASER ACKNOWLEDGES THAT THEY ALONE HAVE DETERMINED THAT THE PRODUCT WILL SUITABLY MEET THE REQUIREMENTS OF THE PURCHASER'S INTENDED USE.

Purchaser's Remedy

Horizon's sole obligation and purchaser's sole and exclusive remedy shall be that Horizon will, at its option, either (i) service, or (ii) replace, any Product determined by Horizon to be defective. Horizon reserves the right to inspect any and all Product(s) involved in a warranty claim. Service or replacement decisions are at the sole discretion of Horizon. Proof of purchase is required for all warranty claims. SERVICE OR REPLACEMENT AS PROVIDED UNDER THIS WARRANTY IS THE PURCHASER'S SOLE AND EXCLUSIVE REMEDY.

Limitation of Liability

HORIZON SHALL NOT BE LIABLE FOR SPECIAL, INDIRECT, INCIDENTAL OR CONSEQUENTIAL DAMAGES, LOSS OF PROFITS OR PRODUCTION OR COMMERCIAL LOSS IN ANY WAY, REGARDLESS OF WHETHER SUCH CLAIM IS BASED IN CONTRACT, WARRANTY, TORT, NEGLIGENCE, STRICT LIABILITY OR ANY OTHER THEORY OF LIABILITY, EVEN IF HORIZON HAS BEEN ADVISED OF THE POSSIBILITY OF SUCH DAMAGES.

Further, in no event shall the liability of Horizon exceed the individual price of the Product on which liability is asserted.

As Horizon has no control over use, setup, final assembly, modification or misuse, no liability shall be assumed nor accepted for any resulting damage or injury. By the act of use, setup or assembly, the user accepts all resulting liability. If you as the purchaser or user are not prepared to accept the liability associated with the use of the Product, purchaser is advised to return the Product immediately in new and unused condition to the place of purchase.

Law

These terms are governed by Illinois law (without regard to conflict of law principals). This warranty gives you specific legal rights, and you may also have other rights which vary from state to state. Horizon reserves the right to change or modify this warranty at any time without notice.

WARRANTY SERVICES

Questions, Assistance, and Services

Your local hobby store and/or place of purchase cannot provide warranty support or service. Once assembly, setup or use of the Product has been started, you must contact your local distributor or Horizon directly. This will enable Horizon to better answer your questions and service you in the event that you may need any assistance. For questions or assistance,

please visit our website at www.horizonhobby.com, submit a Product Support Inquiry, or call the toll free telephone number referenced in the Warranty and Service Contact Information section to speak with a Product Support representative.

Inspection or Services

If this Product needs to be inspected or serviced and is compliant in the country you live and use the Product in, please use the Horizon Online Service Request submission process found on our website or call Horizon to obtain a Return Merchandise Authorization (RMA) number. Pack the Product securely using a shipping carton. Please note that original boxes may be included, but are not designed to withstand the rigors of shipping without additional protection. Ship via a carrier that provides tracking and insurance for lost or damaged parcels, as Horizon is not responsible for merchandise until it arrives and is accepted at our facility. An Online Service Request is available at http://www.horizonhobby.com/content/service-center_render-service-center. If you do not have internet access, please contact Horizon Product Support to obtain a RMA number along with instructions for submitting your product for service. When calling Horizon, you will be asked to provide your complete name, street address, email address and phone number where you can be reached during business hours. When sending product into Horizon, please include your RMA number, a list of the included items, and a brief summary of the problem. A copy of your original sales receipt must be included for warranty consideration. Be sure your name, address, and RMA number are clearly written on the outside of the shipping carton.

NOTICE: Do not ship Li-Po batteries to Horizon. If you have any issue with a Li-Po battery, please contact the appropriate Horizon Product Support office.

Warranty Requirements

For Warranty consideration, you must include your original sales receipt verifying the proof-of-purchase date. Provided warranty conditions have been met, your Product will be serviced or replaced free of charge. Service or replacement decisions are at the sole discretion of Horizon.

Non-Warranty Service

Should your service not be covered by warranty, service will be completed and payment will be required without notification or estimate of the expense unless the expense exceeds 50% of the retail purchase cost. By submitting the item for service you are agreeing to payment of the service without notification. Service estimates are available upon request. You must include this request with your item submitted for service. Non-warranty service estimates will be billed a minimum of ½ hour of labor. In addition you will be billed for return freight. Horizon accepts money orders and cashier's checks, as well as Visa, MasterCard, American Express, and Discover cards. By submitting any item to Horizon for service, you are agreeing to Horizon's Terms and Conditions found on our website http://www.horizonhobby.com/content/service-center_render-service-center.

ATTENTION: Horizon service is limited to Product compliant in the country of use and ownership. If received, a non-compliant Product will not be serviced. Further, the sender will be responsible for arranging return shipment of the un-serviced Product, through a carrier of the sender's choice and at the sender's expense. Horizon will hold non-compliant Product for a period of 60 days from notification, after which it will be discarded.

Warranty and Service Contact Information

Country of Purchase	Horizon Hobby	Contact Information	Address
United States of America	Horizon Service Center (Repairs and Repair Requests)	servicecenter.horizonhobby.com/RequestForm/	4105 Fieldstone Rd Champaign, Illinois, 61822 USA
	Horizon Product Support (Product Technical Assistance)	productsupport@horizonhobby.com 877-504-0233	
	Sales	websales@horizonhobby.com 800-338-4639	

FCC Statement

FCC ID: 2AEV7XBM8NEXTX9GP- (Transmitter RVOH1300)

FCC ID: 2AEV70754-85838579 (Quadcopter RVOH1300-1)

This equipment has been tested and found to comply with the limits for a Class B digital device, pursuant to part 15 of the FCC Rules. These limits are designed to provide reasonable protection against harmful interference in a residential installation. This equipment generates, uses and can radiate radio frequency energy and, if not installed and used in accordance with the instructions, may cause harmful interference to radio communications.

However, there is no guarantee that interference will not occur in a particular installation. If this equipment does cause harmful interference to radio or television reception, which can be determined by turning the equipment off and on, the user is encouraged to try to correct the interference by one or more of the following measures:

- Reorient or relocate the receiving antenna.
- Increase the separation between the equipment and receiver.
- Connect the equipment to an outlet on a circuit different from that to which the receiver is connected.

This device complies with part 15 of the FCC rules. Operation is subject to the following two conditions: (1) This device may not cause harmful interference, and (2) this device must accept any interference received, including interference that may cause undesired operation.

NOTICE: Modifications to this product will void the user's authority to operate this equipment.

This product contains a radio transmitter with wireless technology which has been tested and found to be compliant with the applicable regulations governing a radio transmitter in the 2.400GHz to 2.4835GHz frequency range.

Antenna Separation Distance

When operating your transmitter, please be sure to maintain a separation distance of at least 20 cm between your body (excluding fingers, hands, wrists, ankles and feet) and the antenna to meet RF exposure safety requirements as determined by FCC regulations.

This illustration shows the approximate 20 cm RF exposure area and typical hand placement when operating your transmitter.

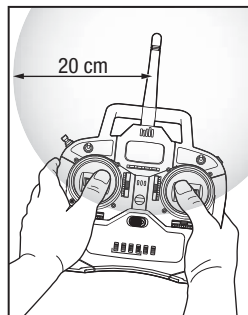

IC Information

IC ID: 23034-XBM57 (Transmitter RVOH1300)

IC ID: 23034-85838579 (Quadcopter RVOH1300-1)

This device complies with Industry Canada license-exempt RSS standard(s). Operation is subject to the following two conditions: (1) this device may not cause interference, and (2) this device must accept any interference, including interference that may cause undesired operation of the device.



©2017 Horizon Hobby, LLC.

Revolution, the Revolution logo, Vizo, and the Horizon Hobby logo are trademarks or registered trademarks of Horizon Hobby, LLC.

All other trademarks, service marks or logos are property of their respective owners.

Updated 10/17

56250.2

RV0H1300