



PRODUCT OPTION
NOTICE: Spektrum™
DX6e 6-Channel DSMX
Transmitter (SPM6650
& SPMR6650)



July 5, 2017

[Download English PDF Version Here \[Document attached below main article\]](#)

Product: Spektrum™ DX6e transmitters that do not have L on the end of the PID number.

Issue: This product notice is for DX6e (without PID ending in L) owners who wish to use the optional lithium ion battery (SPMA9602 battery or SPMA9603 battery/charger set). If you own a DX6e and do NOT wish to use the optional lithium ion battery, please disregard this notice. Transmitters manufactured prior to June of 2017 require a free update to be fully compatible with the optional lithium ion battery. Installing the optional lithium ion battery without completing this update will cause the transmitter to not power down properly and may cause the battery to discharge when the transmitter is powered down.

What To Do: If you own a DX6e with a PID not ending in L and DO wish to use the optional lithium ion battery Please fill out the [Return Request Form found here \[Document attached below main article\]](#). After completing and submitting the Return Request Form, Horizon Hobby will E-mail a pre-paid shipping label for you to use to return the transmitter. DO NOT SEND BATTERIES with the transmitter to Horizon Hobby. Horizon Hobby will return the transmitter to you as soon as the update is completed. Please allow 14-21 days for processing and delivery.

Finding the PID number:

The PID number is a manufactured identification number and is located under the battery lid inside the battery compartment on the DX6e as shown. Only PID's that do not end in a L need to be returned for updating.

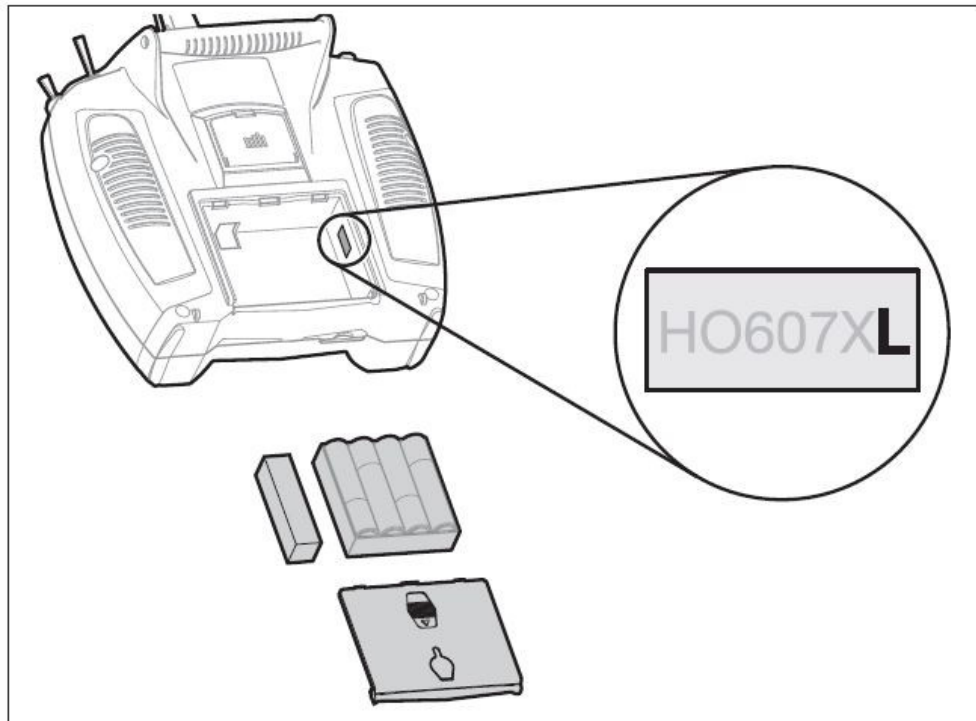

Returning for Free Update Action:

1. Remove the following items from the transmitter:

- Transmitter Battery
- Neck Strap
- Any Aftermarket Accessories (cell phone mounts, Gimbal sticks, etc...)

2. Carefully wrap the transmitter in bubble wrap and pack the transmitter into a strong cardboard box, ensuring the transmitter will not move around in transit.

3. Attach shipping label and return address on outside of box

If you purchased your product outside of the US and Canada, please see the retailer or distributor you purchased your product from for assistance.

Horizon Hobby, LLC disclaims all liability and warranties for any consumer who does not act upon this notice. We apologize for this inconvenience. If you have any questions, please call Horizon Hobby Product Support at 877-504-0233.

Contact Information

Country of Purchase	Horizon Hobby	Contact Information	Address
United States of America	Horizon Product Support (Product Technical Assistance)	productsupport@horizonhobby.com 877-504-0233	4105 Fieldstone Rd Champaign, Illinois, 61822 USA
	Sales	sales@horizonhobby.com	

©2017 Horizon Hobby, LLC. PowerSafe, DSMX, Horizon Hobby and the Horizon Hobby logo are trademarks or registered trademarks of Horizon Hobby, LLC.

The Spektrum trademark is used with permission of Bachmann Industries, Inc. 56384

EN

This product notice is for DX6e owners who wish to use the optional lithium ion battery (SPMA9602 battery or SPMA9603 battery/charger set). If you own a DX6e and do NOT wish to use the optional lithium ion battery, please disregard this notice.

Transmitters manufactured prior to June of 2017 require a free update to be fully compatible with the optional lithium ion battery. Installing the optional lithium battery without completing this update will cause the transmitter to not power down properly and may cause the battery to discharge when the transmitter is powered down. DX6e transmitters manufactured after June of 2017 have been updated at the factory and do not require additional updates. Transmitters updated at the factory have an "L" at the end of the PID code located in the battery compartment.

To check the PID code of your transmitter:

1. Remove the battery compartment cover.
2. Remove the rectangular foam insert next to the battery holder.
3. Remove the AA battery holder from the battery compartment.
4. Check the PID code on the decal applied to the side of the battery compartment.
If the code ends in "L" the updates have been completed at the factory and your transmitter is fully compatible. If the code does not end in "L" your transmitter must be updated prior to installing the optional lithium ion battery.

To have this free update applied to your transmitter, complete the included form and submit it to Horizon Hobby Product Support Bulletins at hhps@horizonhobby.com to receive a return shipping label. Return your transmitter, without the battery, to Horizon Hobby.

For customers living outside of North America, please contact your place of purchase.

NOTICE: Do not ship LiPo or Lithium Ion batteries to Horizon Hobby. If you have any issue with a LiPo or Lithium Ion battery, please contact the appropriate Horizon Product Support office.

After the updates are completed and your transmitter is returned, follow the instructions and warnings in your DX6e manual for installation and charging of the optional lithium ion battery.

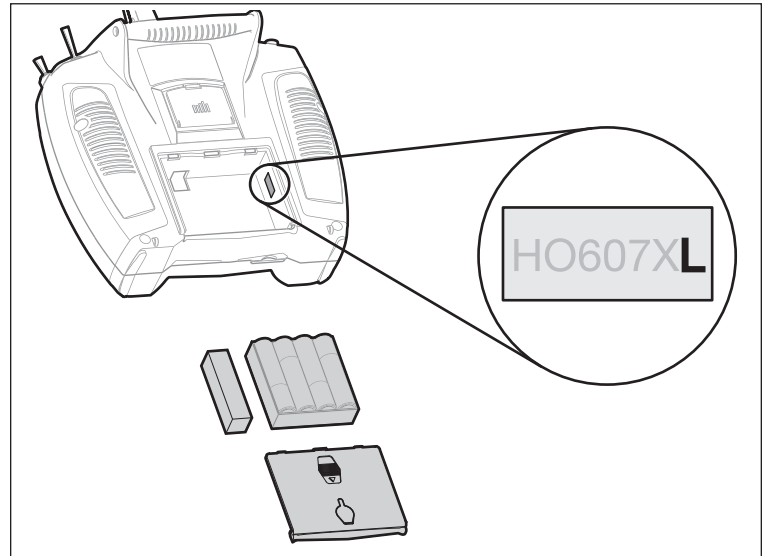



Spektrum DX6e Transmitter Return Request Form

Consumer Shipping Address:

Name: _____

Street: _____

City: _____

State/Province: _____

Postal/Zip Code: _____

Phone Number: _____

E-mail: _____

Quantity: _____

Location of Purchase: _____

Notes:

North American Instructions:

Complete this **Return Request Form** and click the **Submit This Form** button at the bottom of the page.

Upon processing of the completed form, a pre-paid shipping label will be sent to you via email. If no email address is provided on the Return Request form, the shipping label will be mailed to you. Return your transmitter, along with a printed copy of the completed Return Request form. If you require assistance contact Horizon Hobby Product Support Bulletins at hhps@horizonhobby.com. **Do not send batteries with the transmitter** to Horizon Hobby. Horizon Hobby will return the transmitter to you as soon as the update is completed. Please allow 14–21 days for processing and delivery.

For Customers Outside of North America:

For customers located outside of North America or Europe, please contact your place of purchase.