

BLADE III 700X

#1 BY DESIGN



Instruction Manual
Bedienungsanleitung
Manuel d'utilisation
Manuale di Istruzioni

SPEKTRUM™ DSMX™ CONTROL + BEASTX™ FLYBARLESS TECHNOLOGY



NOTICE

All instructions, warranties and other collateral documents are subject to change at the sole discretion of Horizon Hobby, Inc. For up-to-date product literature, visit horizonhobby.com and click on the support tab for this product.

Meaning of Special Language

The following terms are used throughout the product literature to indicate various levels of potential harm when operating this product:

The purpose of safety symbols is to attract your attention to possible dangers. The safety symbols, and their explanations, deserve your careful attention and understanding. The safety warnings do not by themselves eliminate any danger. The instructions or warnings they give are not substitutes for proper accident prevention measures.

NOTICE: Procedures, which if not properly followed, create a possibility of physical property damage AND a little or no possibility of injury.

CAUTION: Procedures, which if not properly followed, create the probability of physical property damage AND a possibility of serious injury.

WARNING: Procedures, which if not properly followed, create the probability of property damage, collateral damage, serious injury or death OR create a high probability of superficial injury.



Safety Alert: Indicates warning or caution. Attention is required in order to avoid serious personal injury.



WARNING: Read the ENTIRE instruction manual to become familiar with the features of the product before operating. Failure to operate the product correctly can result in damage to the product, personal property and cause serious injury.

This is a sophisticated hobby product for advanced helicopter pilots with previous experience in the operation of CCPM helicopters (Cyclic Collective Pitch Mixing or Collective Pitch Helicopter) such as the Blade SR, Blade mCP X or Blade 300 X, and previous kit building experience, such as the Blade 550 X or Blade 600 X. It must be operated with caution and common sense and requires some basic mechanical ability. Failure to operate this product in a safe and responsible manner could result in injury or damage to the product or other property. This product is not intended for use by children without direct adult supervision. Do not use with incompatible components or alter this product in any way outside of the instructions provided by Horizon Hobby, Inc. This manual contains instructions for safety, operation and maintenance. It is essential to read and follow all the instructions and warnings in the manual, prior to assembly, setup or use, in order to operate correctly and avoid damage or serious injury.

Age Recommendation: For advanced fliers ages 14 and above. This is not a toy.

General Safety Precautions and Warnings

This model is controlled by a radio signal subject to interference from many sources outside your control. Interference can cause momentary loss of control.

- Always ensure you fully understand the controls on your transmitter and how they affect the movement of the helicopter.
- Always operate your model outdoors in large, open spaces away from full-size vehicles, traffic and people to avoid collisions or injury
- Always carefully follow the manufacturer's directions and warnings for any related equipment (i.e., chargers, rechargeable battery packs, etc.).
- Always keep the product, related chemicals, small parts and electrical components out of the reach of children.
- Always keep children out of the vicinity of this product at all times.
- Always store this product well out of the reach of children.
- Always keep hair secured above your shoulders so it cannot get caught in the blades.
- Always avoid water exposure to all equipment not specifically designed and protected for this purpose. Moisture causes damage to electronics.
- Never maintain and operate this product at night, in rain or in inclement weather.
- Always ensure all fasteners are secure before use.
- Always store product in a dry, temperate, secure location
- Do not touch the motor as it can become extremely hot during use.
- Do not fly this helicopter indoors
- Always ensure the failsafe is properly set before flying. Do not exclusively rely on the safety mechanisms built into your transmitter and receiver.
- Always ensure you understand the product and how to operate it.
- Only use Horizon-approved replacement parts and accessories for this product.
- Never place any portion of the model in your mouth as it could cause serious injury.
- Never operate your transmitter or helicopter with low transmitter batteries.
- Never connect the battery unless using or testing the product. Do not perform maintenance with the battery installed.
- Never operate this product if you are tired, ill, taking any medications that impair judgment or are under the influence of alcohol or drugs.
- Never spray glass cleaner or any other liquid on this product.
- Always keep hair and dangling or loose items well away from the blades when the battery is connected.

NOTICE: Modification with non-Horizon-approved components may result in refusal of service by Horizon.



WARNING: This is a large model helicopter with carbon fiber blades that spin at very high RPM. Always use extreme caution and common sense when maintaining and operating this product. If you are unsure about ANY function or procedure described in this manual, DO NOT operate. Contact Horizon Product Support for assistance.



WARNING: Always ensure you are operating the helicopter a safe distance, 45 feet (13 meters), away from yourself and others.

BLADE III 700X

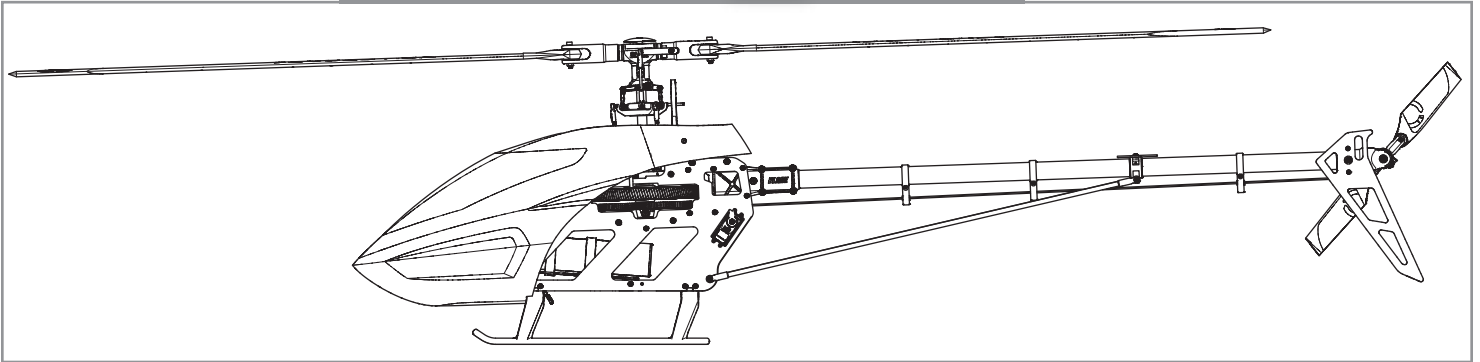

Welcome to the world of *Blade*® Pro Series helicopter performance. Over two decades of flying and design experience has gone into the development of the *Blade* 700 X. Every part, down to the nuts and bolts, has been chosen or designed with one goal in mind – giving you a 700-size 3D machine that is second to none.

Before you tear into the contents of this box, however, you must review this manual. It's been written and designed to make assembling the *Blade* 700 X one of the most enjoyable, hassle-free building experiences you'll ever have. Every step is clearly illustrated and shows what parts are needed to complete it.

If this is your first helicopter building experience, there are a few things you might want to get before you start unpacking parts. Many builders prefer to lay out a towel or a rubber mat to prevent screws from bouncing off the worktable. It's also a good idea to use small containers to keep parts organized after you take them out of the bags.

Most importantly, take your time. Review every assembly step and make sure you understand how the parts fit before you start bolting things together. When you're done, you'll have a capable, smooth-flying helicopter that flies exactly as it was designed to.

Table of Contents

Tools Needed to Complete	4	Flight Guidelines and Warnings	21
Required Items	4	Flying Your 700X	21
Optional Items	4	Blade Tracking	22
Assembly Guide	4	Adjusting the Rudder Gain.....	22
Head Assembly (H).....	5	Post Flight Inspection and Maintenance Checklist	22
Frame Assembly (F)	8	AR7200BX Fine-Tuning and Adjustment	22
Tail Assembly (T).....	14	Troubleshooting Guide	23
ESC and Battery Tray Assembly.....	18	Limited Warranty	24
Main Rotor Installation	20	Warranty and Service Contact Information	25
Programming Your Transmitter	20	Compliance Information for the European Union.....	25
Throttle Hold.....	20	Exploded Views.....	98-101
AR7200BX Parameter Menu Tips	20	Parts List / Ersatzteile / Pièces de rechange / Pezzi di ricambio.....	102-103
Motor Direction Test.....	21	Optional Parts / Optionale Bauteile / Pièces optionnelles / Pezzi opzionali.....	103
Low Voltage Cutoff.....	21		

Blade 700 X Specifications

Length	53.3 in (1350mm)	Tail Rotor Diameter	12 in (306mm)
Height	15.5 in (395 mm)	Flying Weight	11–11.6 lb (5,000–5,800 g)
Main Rotor Diameter	64.3 in (1635mm)		

	Component	Kit	Combo
Motor	E-flite 700 Motor: 520Kv	required	included
ESC	E-flite 100 Amp HV ESC	required	required
Battery	2 x 6S 22.2V 5000mAh 30C + Li-Po	required	required
Charger	DC Li-Po Balancing Charger	required	required
Main Rotor Blades	Revolution 690mm FBL 3D Carbon Main Blades	required	included







	Component	Kit	Combo
Transmitter	DSM2®/DSMX® compatible transmitter	required	required
Receiver	AR7200BX 7CH DSMX Flybarless Control System	required	included
Swash Servos	Spektrum H6200 (x3)	required	included
Tail Servo	Spektrum H6210	required	included

To register your product online, visit www.bladehelis.com

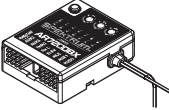
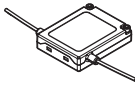

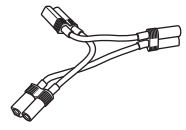
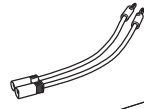

Tools Needed To Complete

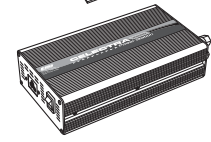
- 1.5mm, 2mm, 2.5mm, 3mm and 4mm hex drivers
- Ball link pliers
- Needle nose pliers
- Phillips screwdriver
- Wire cutter
- Pitch gauge
- Metric calipers
- Petroleum-based, light viscosity lube
- Medium cyanoacrylate (CA)

Required Items

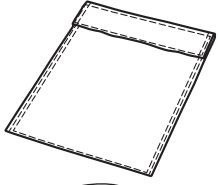
- Receiver/Flybarless control unit *AR7200BX (SPMAR7200BX)* included with combo *BLH5725C* 
- *DSMX Remote Receiver (SPM9645)* included with combo *BLH5725C* 
- 3 Servos
(3) *H6200 servos (SPMSH6200)* included with combo *BLH5725C* 
- 1 Tail servo
(1) *H6210 servo (SPMSH6210)* included with combo *BLH5725C* 
- (2X) 5000mAh 6S 22.2V 30C Li-Po, 10AWG with EC5™ connector (EFLB50006S30) 
- E-flite® EC5 Battery Series Harness, 10 AWG (EFLAEC508) 
- E-flite EC5 Device Charge Lead with 6" Wire & Jacks, 12 AWG and EC5 connector (EFLAEC512) 
- E-flite 200W charger (EFLC3020) 
- Celecra™ 15VDC 250W Power Supply (EFLC4010) 
- DSM2®/DSMX® compatible DX6i 6 channel transmitter or higher

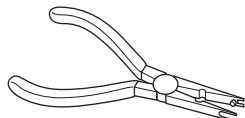
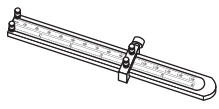
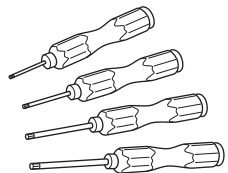
Optional Items

- Dynamite® Li-Po Charge Protection Bag, Large (DYN1405) 
- Revolution® Ball Link Tool (RVO1009) 
- Revolution Deluxe Ball Link Pliers (RVO1005) 
- Control Rod Set Up Tool (RVO1004) 
- Revolution Hex Driver Set, 1.5/2.0/2.5/3.0mm (RVO2000) 
- Revolution 2.5mm Option Extended Hex Tip (RVO2012) 
- Revolution Low-Bounce Rubber Work Mat (RVO1020) 

Assembly Guide Legend



Apply BLUE Threadlock



Apply NO Threadlock



Apply Petroleum-Based, Light Viscosity Lube



Apply Synthetic Grease



Apply MEDIUM CA



Loosely Tighten



Fully Tighten

2X

Repeat Multiple Times

Head Assembly (H)

Step H1

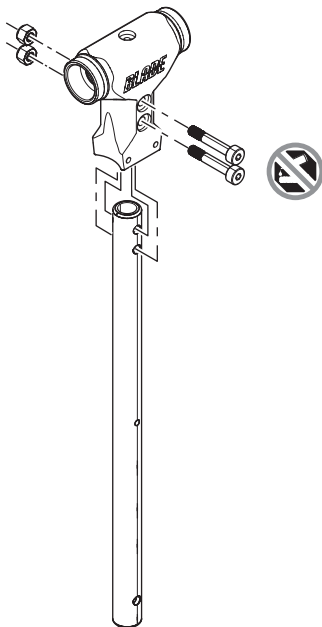

Step H1 parts (bags H1 and H2)

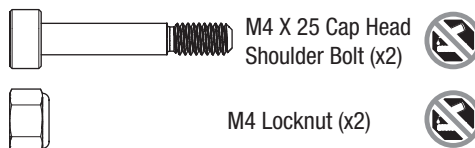

Step H2

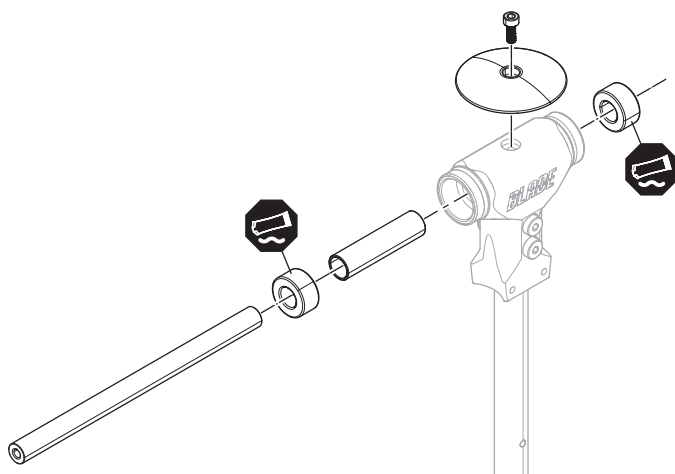

Step H2 parts (bags H1 and H2)

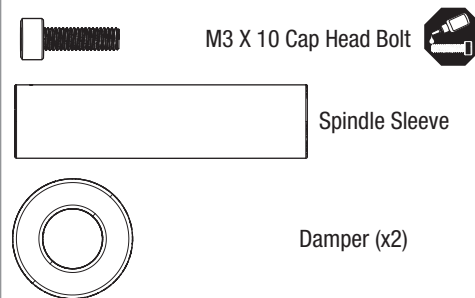

- Clean the threads in the spindle thoroughly with alcohol before installation.

Step H3

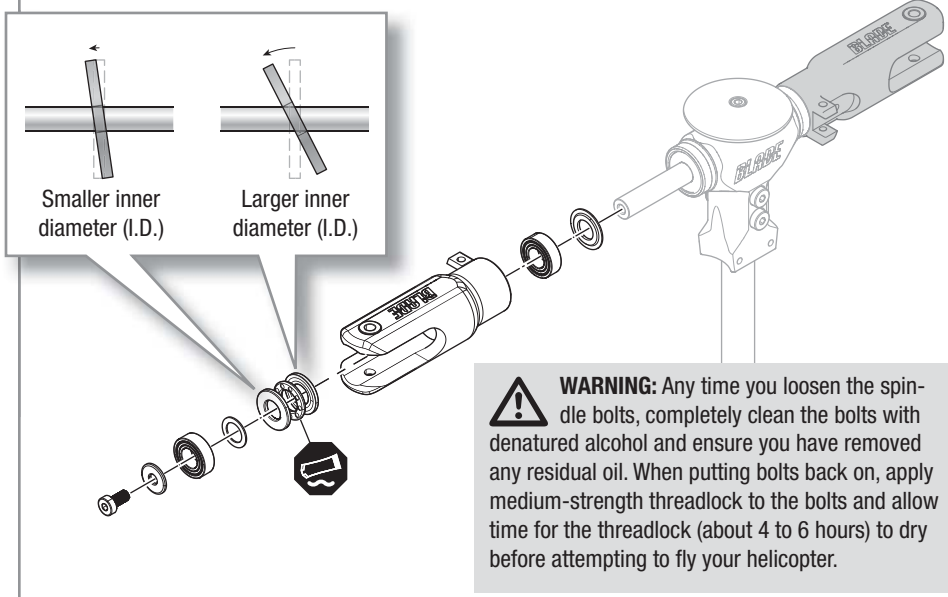

Step H3 parts (bag H3)

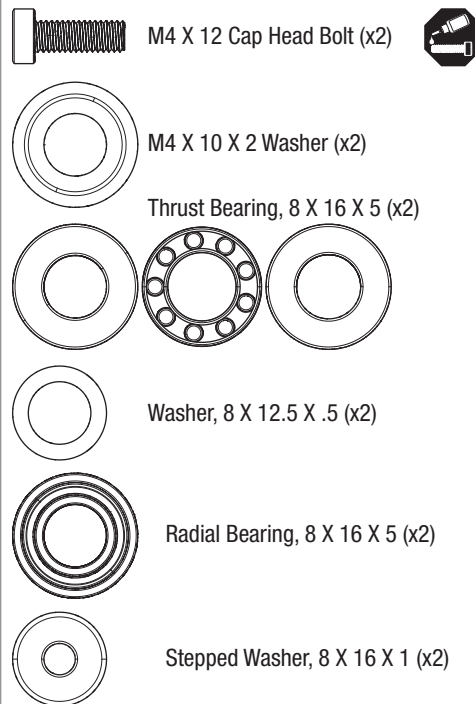



- The stepped sides of the washers should face the radial bearings.

Head Assembly cont'd

Step H4 parts (bag H4)

 M3 X 14 Button Head Bolt (x2) 

 M3 X 12 Button Head Bolt (x2) 

 Control Ball (x2) 

- Loosely install bolts A and B before tightening.

Step H4

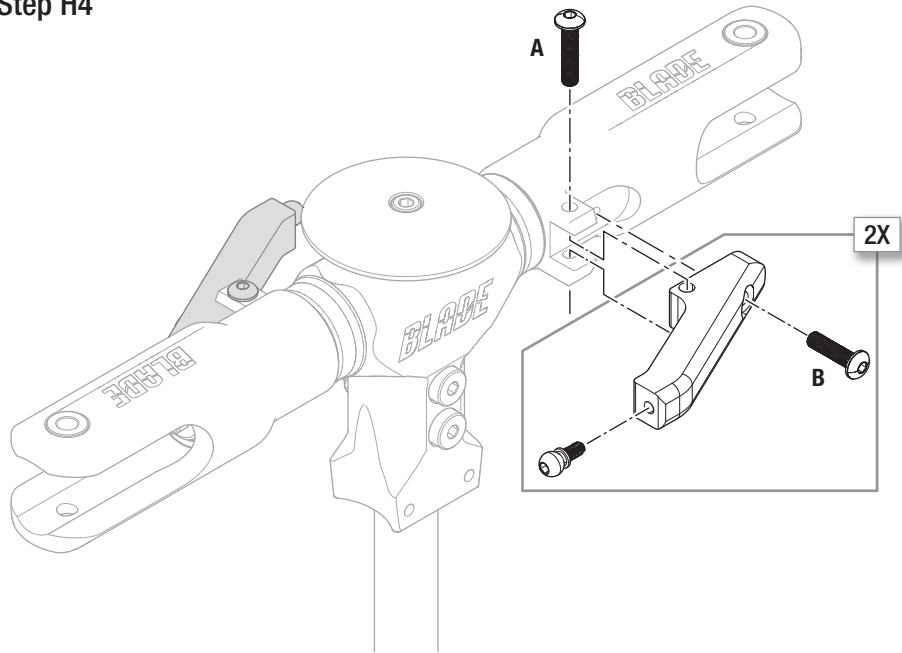

Step H5 parts (bag H5)

 M3x12 Cap Head Bolt (x2) 

 Washer 3 X 4 X .5 (x4)

 Radial Bearing 3 X 6 X 2.5 (x4)

 Brass Spacer (x2)

- The stepped sides of the washers should face the radial bearings.
- Do not over-tighten. The follower arms should move freely.

Step H5

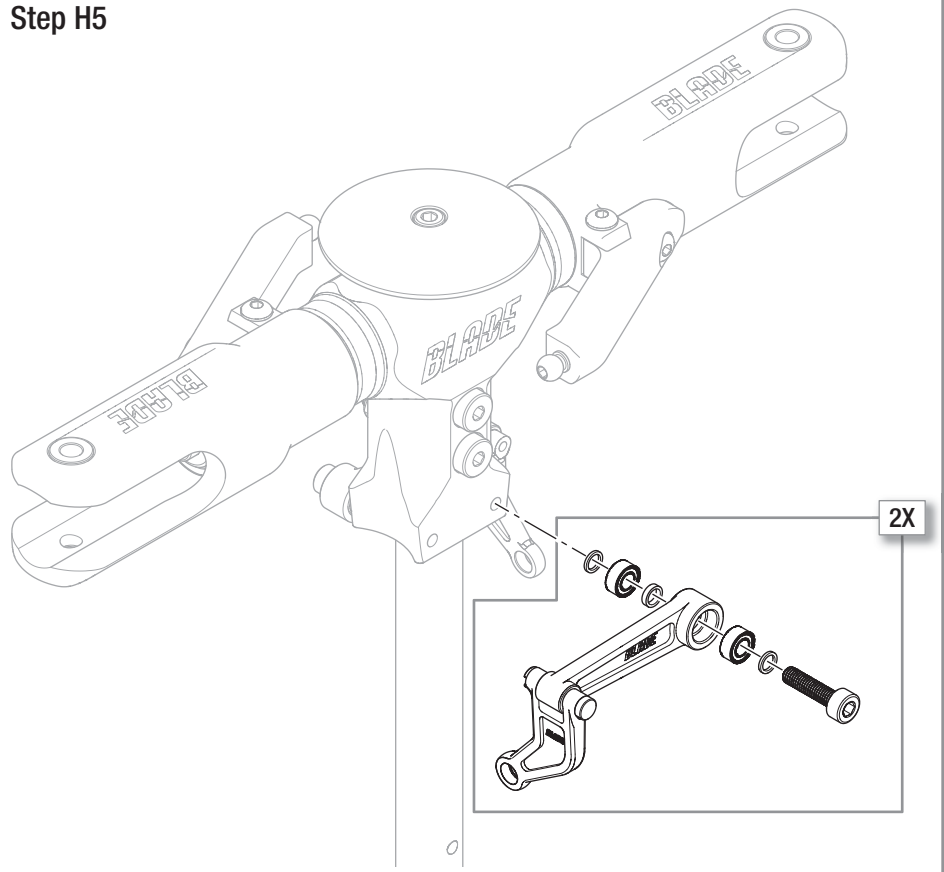

Head Assembly cont'd

Step H6

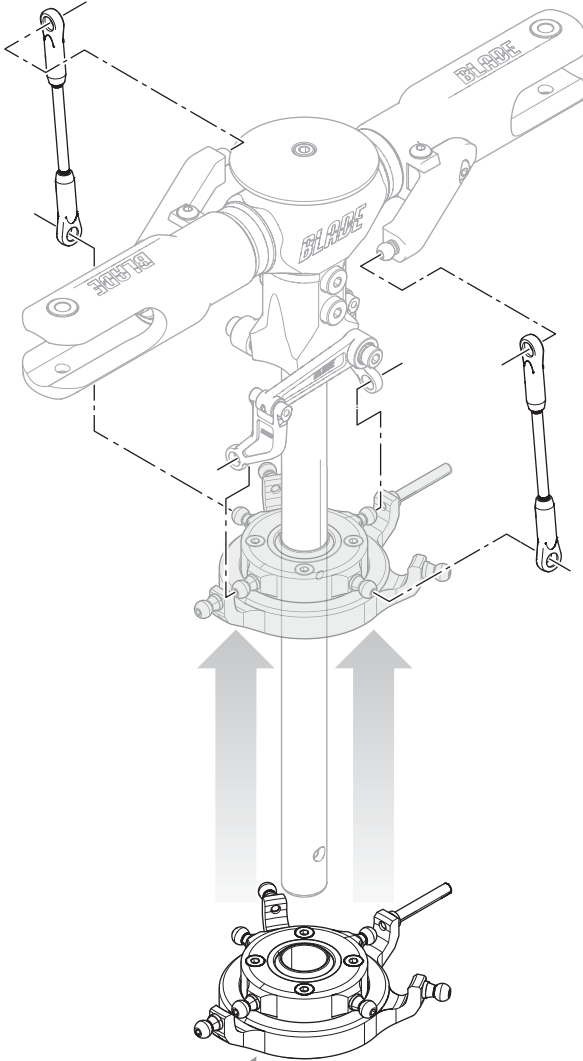

Step H6 parts (H6)

M3 X 50 Control Rod (x2)

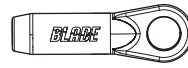
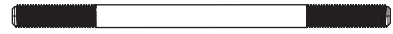

M3 Ball Link

Pushrod lengths

67mm

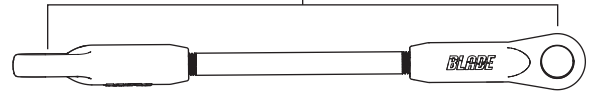

Swash to blade grip link (x2)

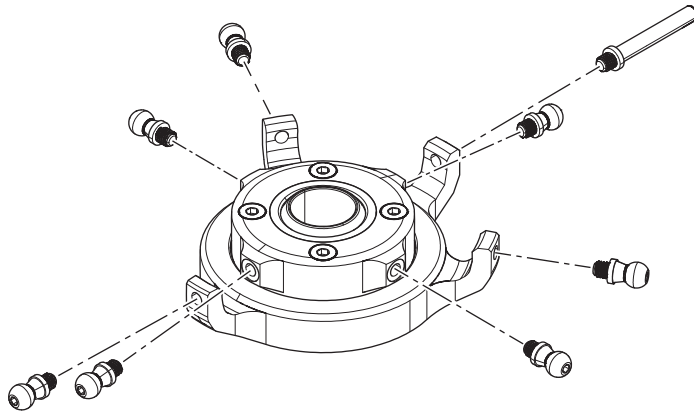
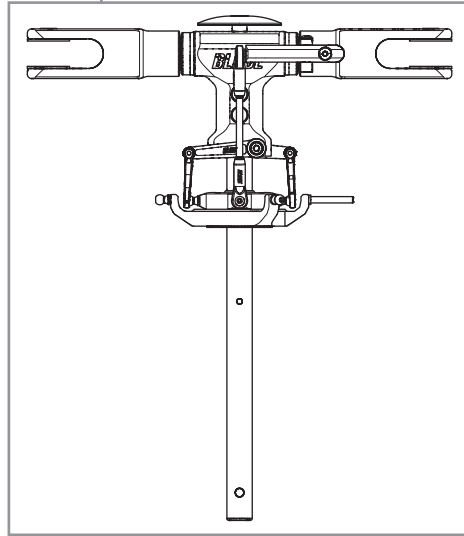

Anti-Rotation Pin

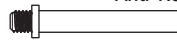

Control Ball (x7)



Frame Assembly (F)

NOTICE: Before assembly, plan your wire routing for the servos. At any point where the servo wire is going to pass through or cross the frame plates, use sandpaper to round the edge of the frame plate to prevent the wire from chafing.

Step F1 parts (bags F1 and F2)



M3 X 8 Cap Head Bolt
(x20)



Washer M3 (x4)

- At this stage of the assembly, do not tighten the bearing block screws.
- If desired, the swash servos may be installed at this step, before the bearing blocks are installed into the frame. Please see step F6 for servo installation parts and procedure.

Step F1

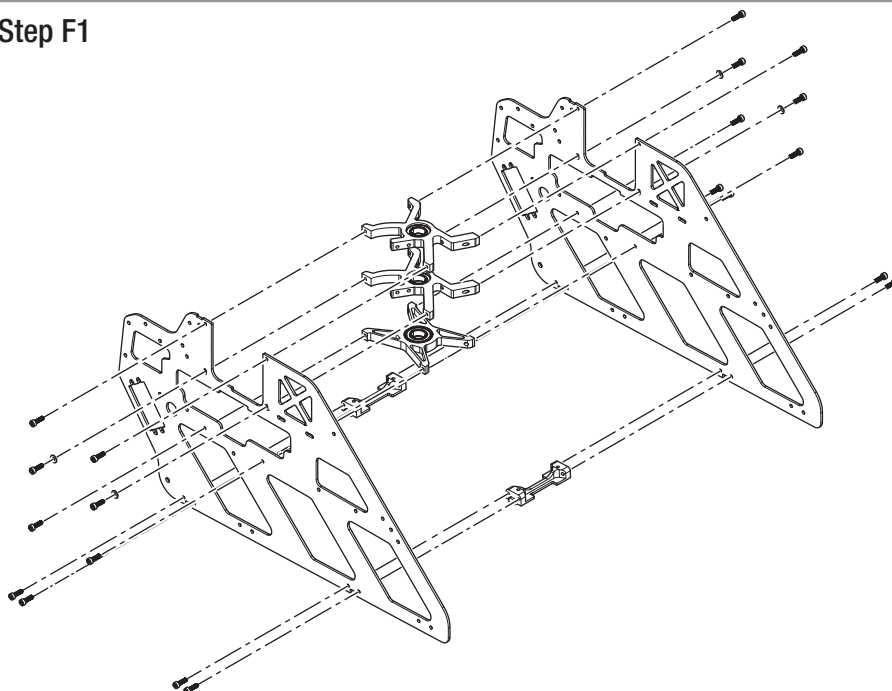

Step F2 parts (bag F3)



M3 X 14 Cap Head Bolt (x4)



Washer M3 (x4)

Step F2

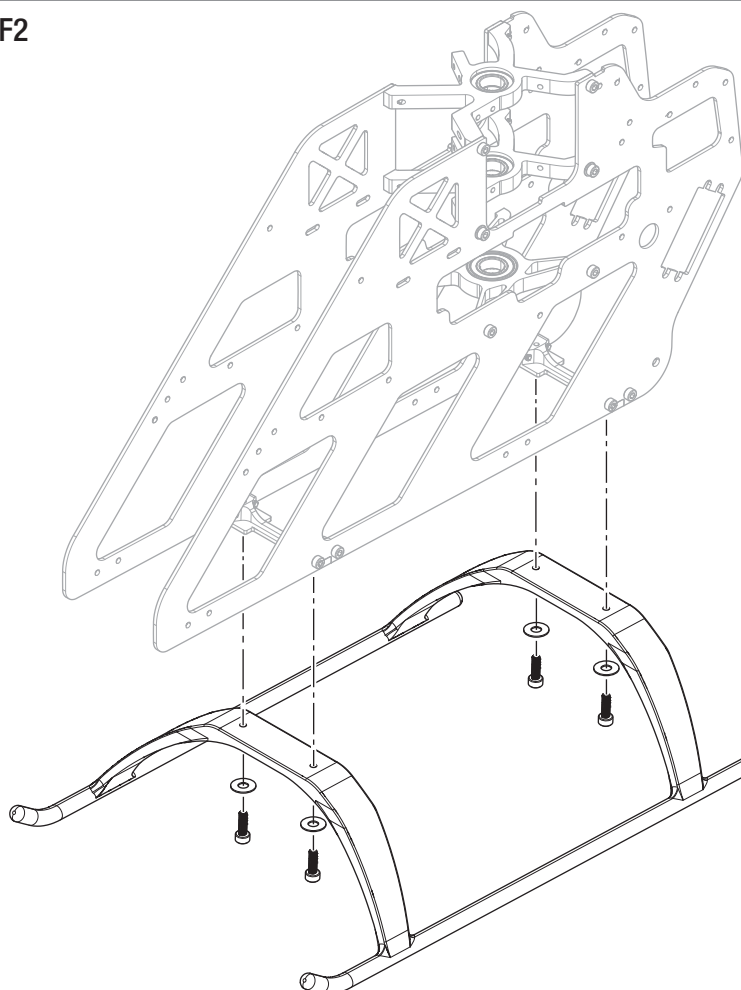

Frame Assembly cont'd

Step F3

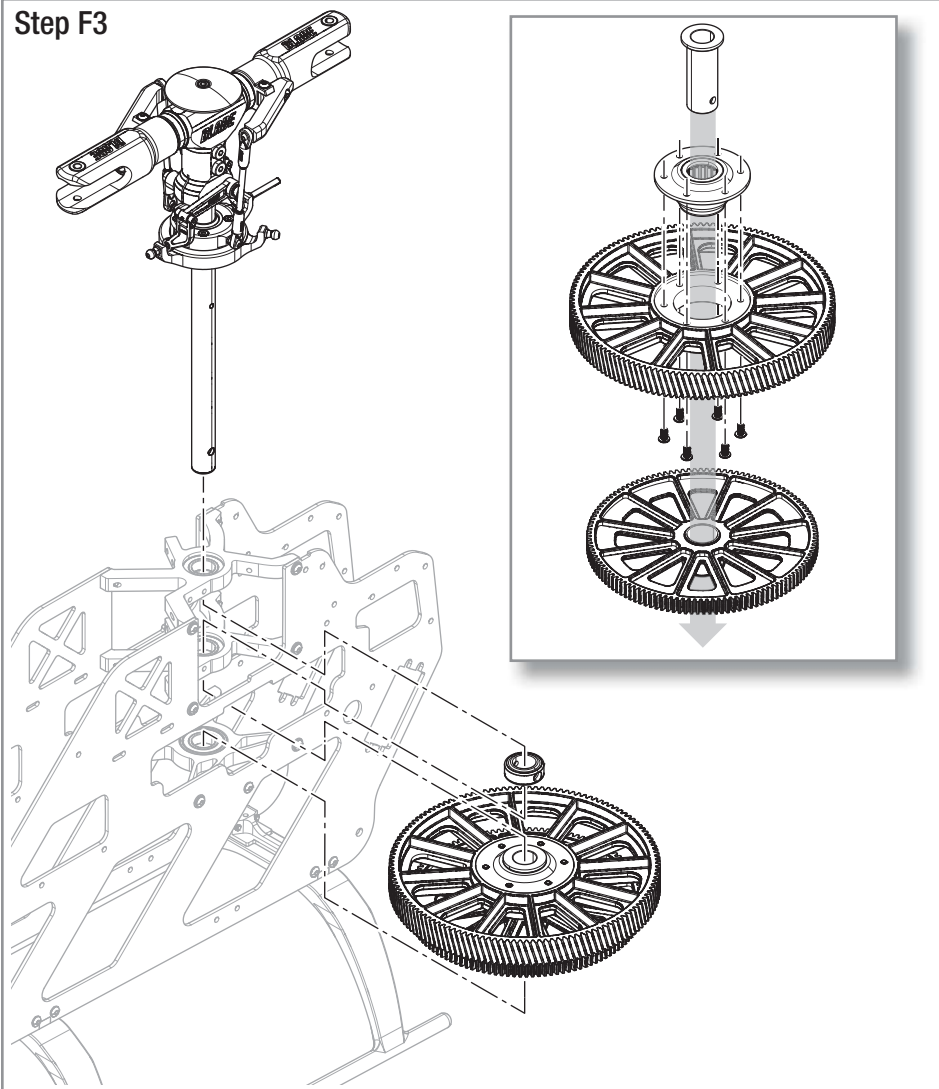

Step F3 parts (bag F4)

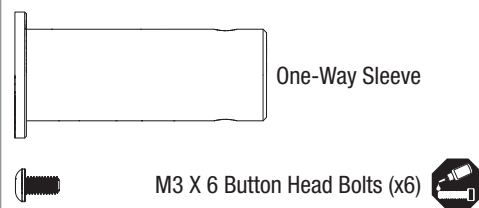

- Slide the mainshaft into position, then tighten all the frame screws.
- A .5mm or 1mm shim may be added above the collar if needed.

Step F4

Frame side removed for clarity

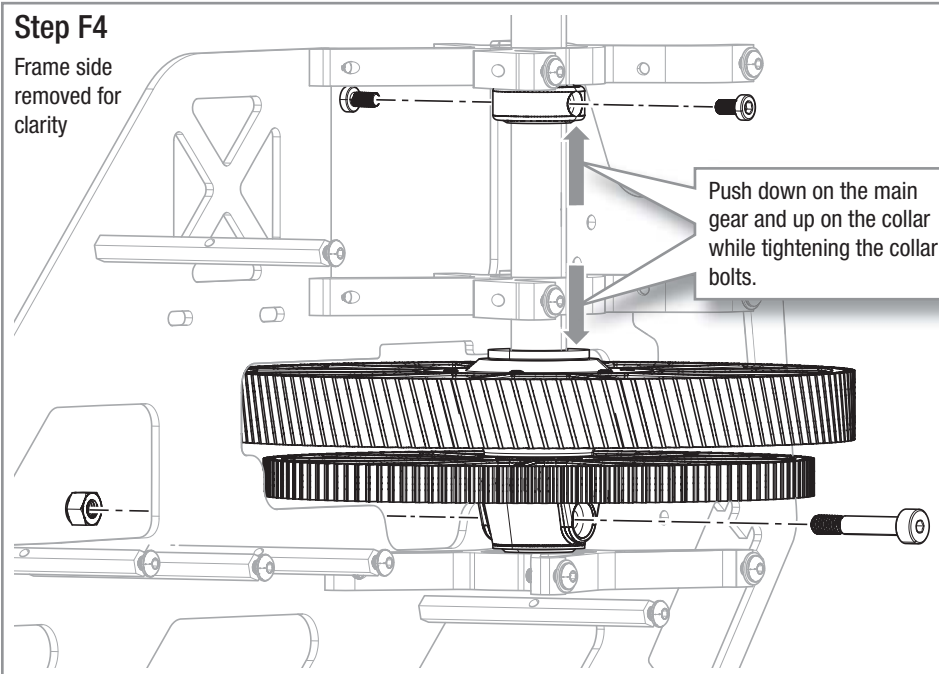



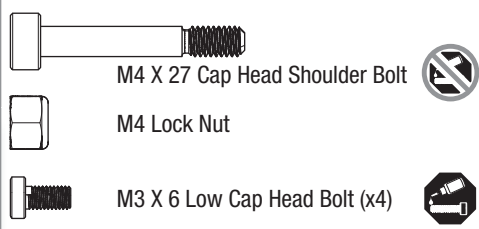



Step F4 parts (bag F4)



Frame Assembly cont'd

Step F5 parts (bag F5)

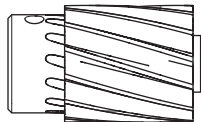





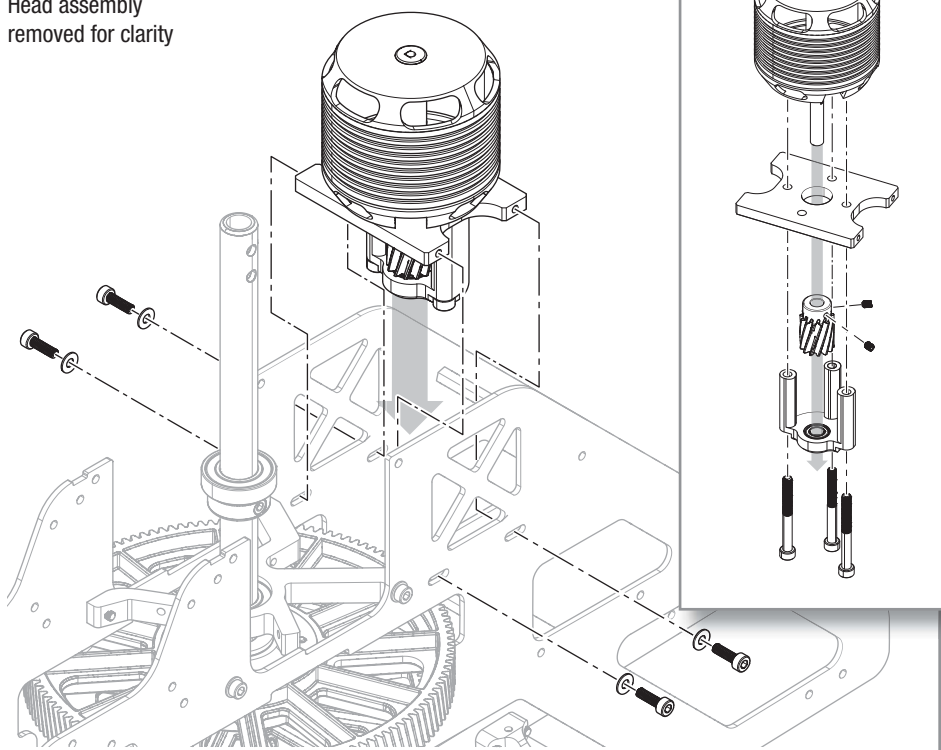



-  M4 X 40 Cap Head Shoulder Bolt (x3) 
-  M3 X 8 Cap Head Bolt (x4) 
-  M3 Washer (x4)
-  M4 X 4 Set Screw (x2) 
-  Pinion Helical Mod 1, 13T, 6mm

Step F5

Head assembly removed for clarity

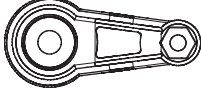
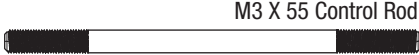

Step F6 parts (bag F6)

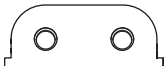
-  **A** M3 X 8 Cap Head Bolt (x3) 
-  **B** M3 X 10 Cap Head Bolt (x12) 
-  M3 Washer (x12)
-  M2 X 12 Button Head Bolt (x3) 
-  M2 Nut (x3)
-  Servo Control Ball (x3)
-  Servo Horn (x3)
-  M3 X 55 Control Rod (x3)
-  M3 Ball Link (x6)
-  Servo Spacer (x6)

Step F6

Aileron servos

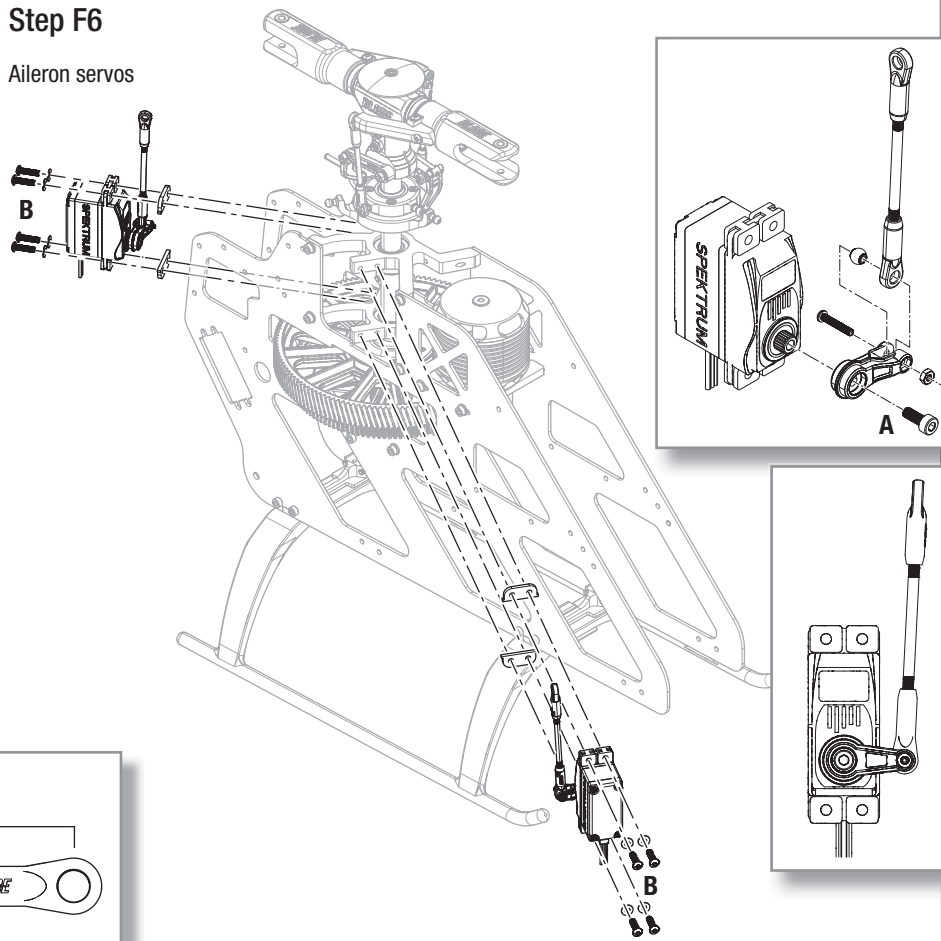

Pushrod lengths

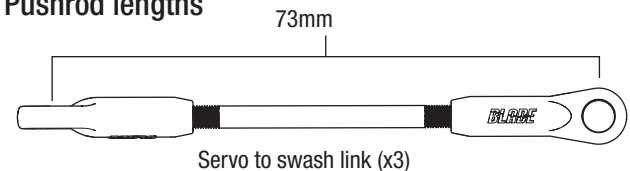

Frame Assembly cont'd

Step F6 contd.

Elevator servo

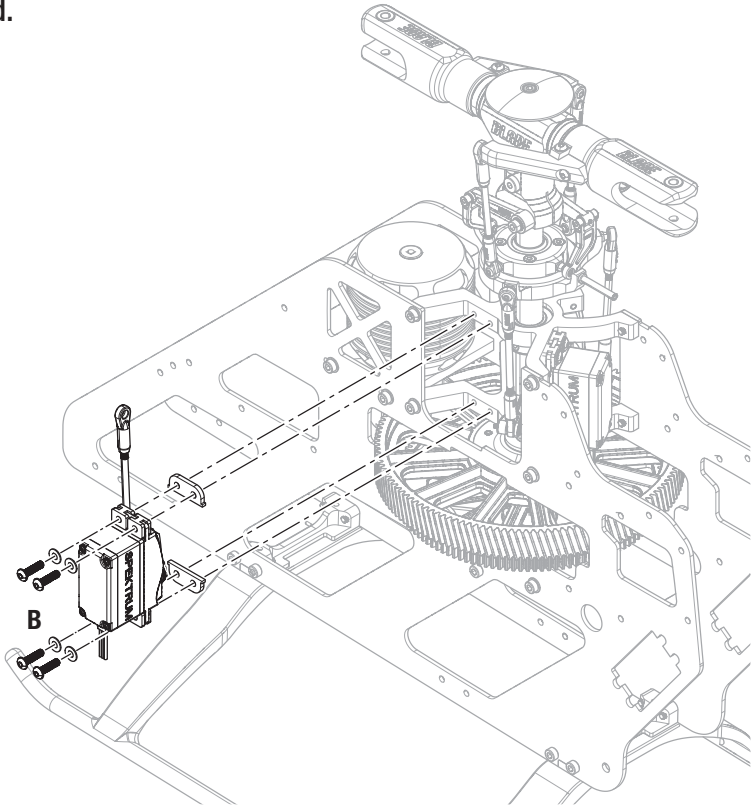



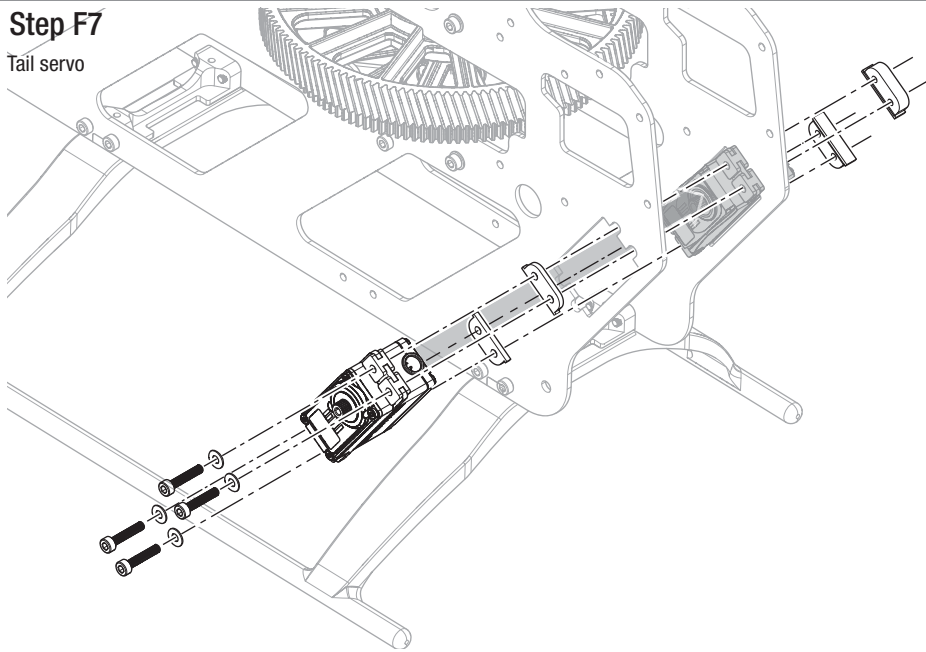

Step F7

Tail servo



Step F7 parts (bag F6)

-  M3 X 16 Cap Head Bolt (x4) 
-  M3 Washer (x4)
-  Servo Spacer (x2)
-  Tail Servo Nut (x2)

Frame Assembly cont'd

Step F9 parts (bag F7)

 M3 X 8 Cap Head Bolt (x4)

Step F9

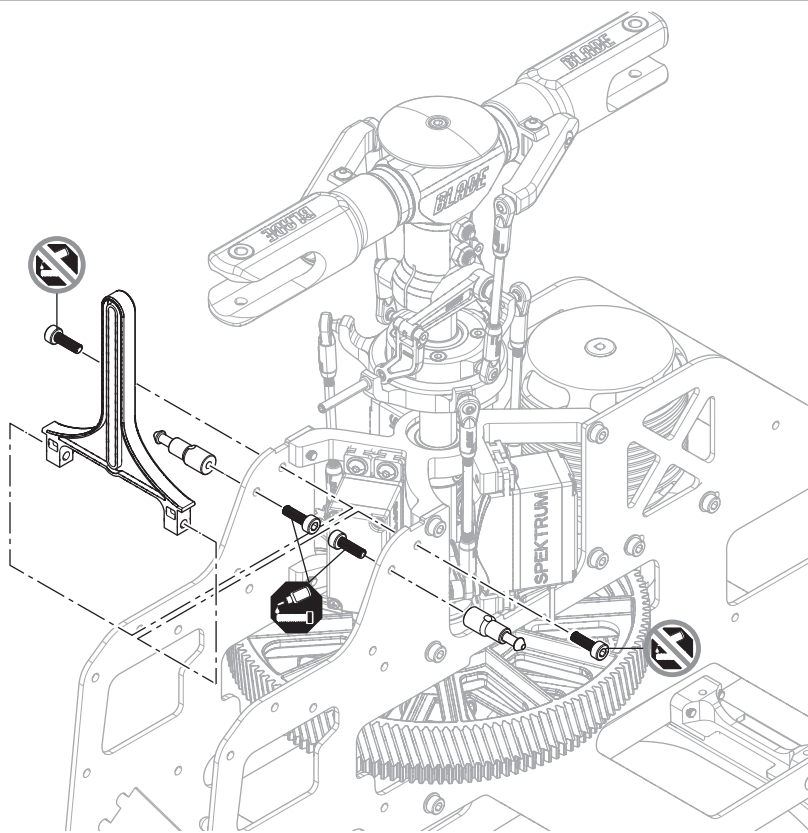

Step F10 parts (bag F8)

Hexagonal Posts (x6)

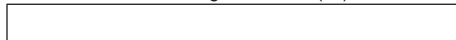

Jack Shaft

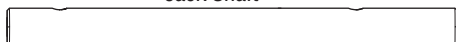

Radial Bearing 12 X 18 X 4 (x2)



Radial Bearing 5 X 10 X 4 (x2)



Gear Pin (x2)



M3 X 4 Set Screw (x2)



Step F10

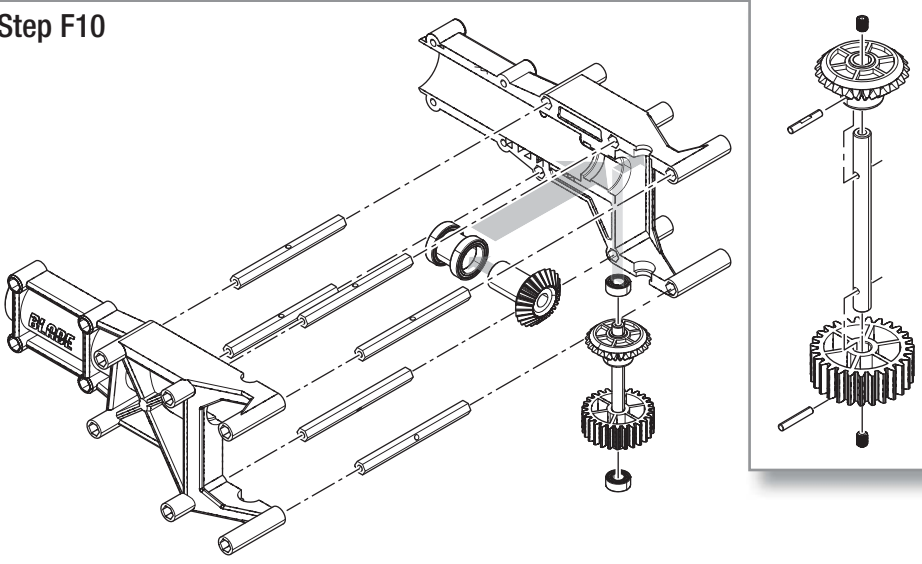

Frame Assembly cont'd

Step F11

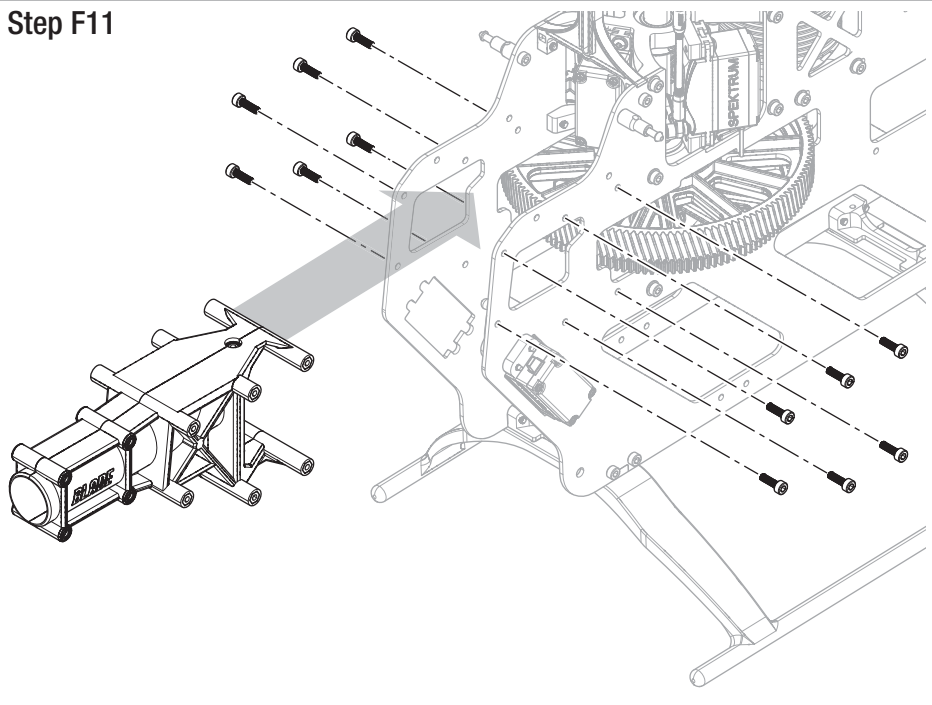

Step F11 parts (bag F8)



M3 X 8 Cap Head Bolt (x12)



Step F12

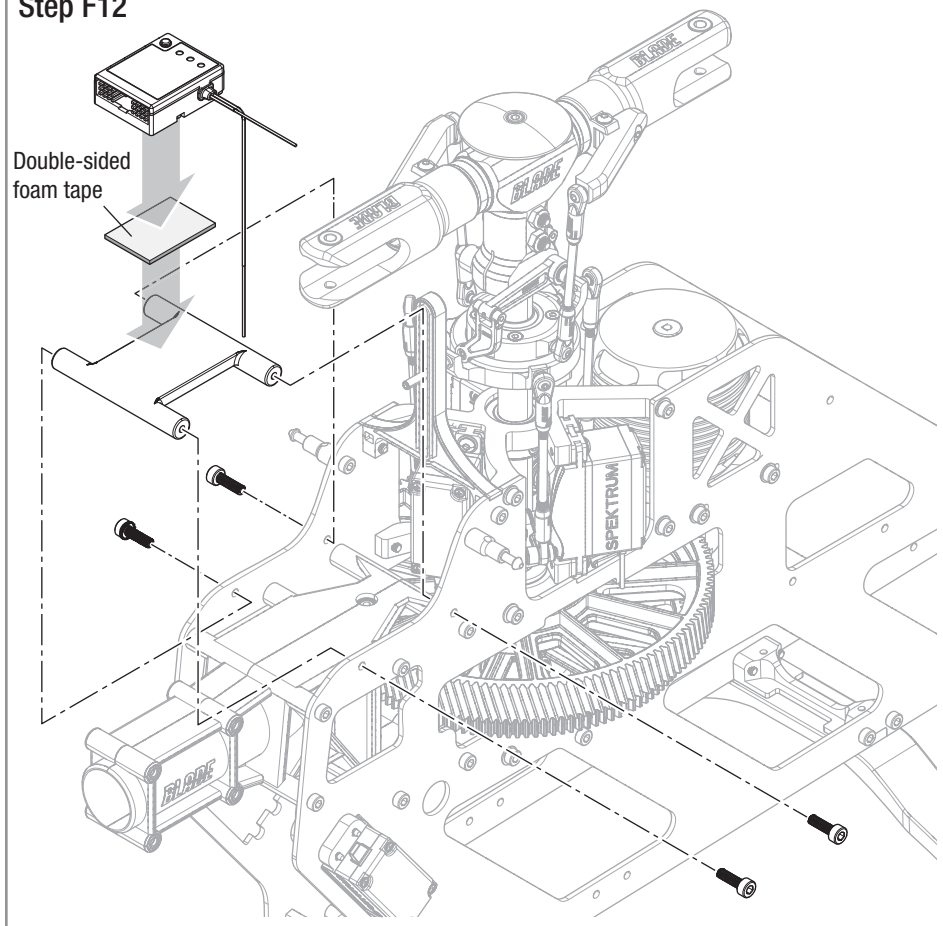

Step F12 parts (bag F9)



M3 X 8 Cap Head Bolt (x4)



AR7200BX Alignment

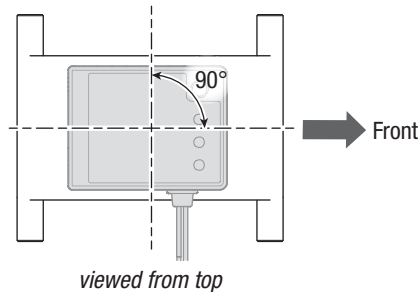

Tail Assembly (T)

Step T1 parts (bag T1)



Step T1

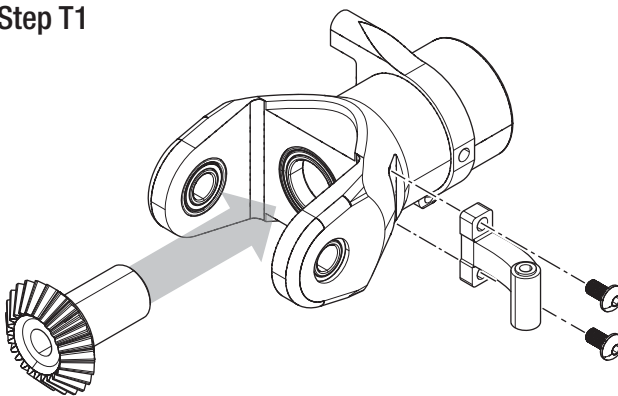

Step T2 parts (bag T2)



Step T2

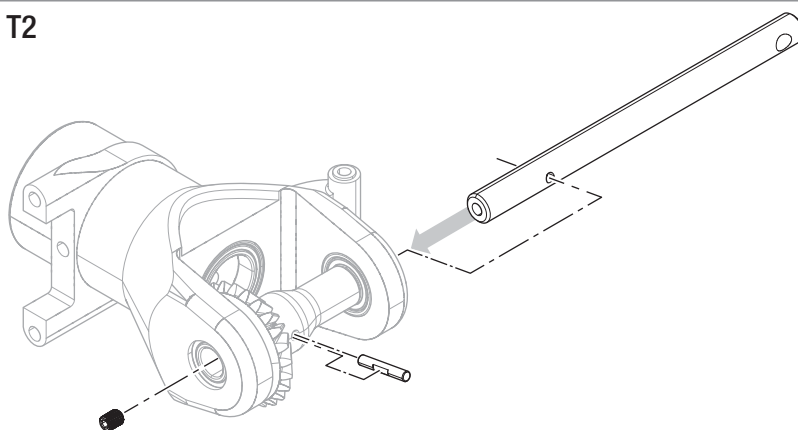

Step T3 parts (bag T3)

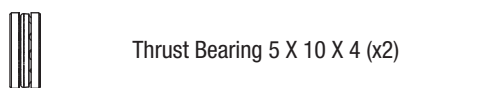
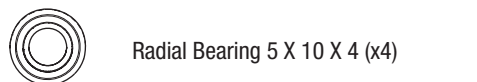
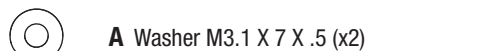
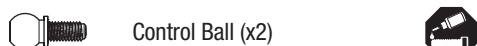

Step T3

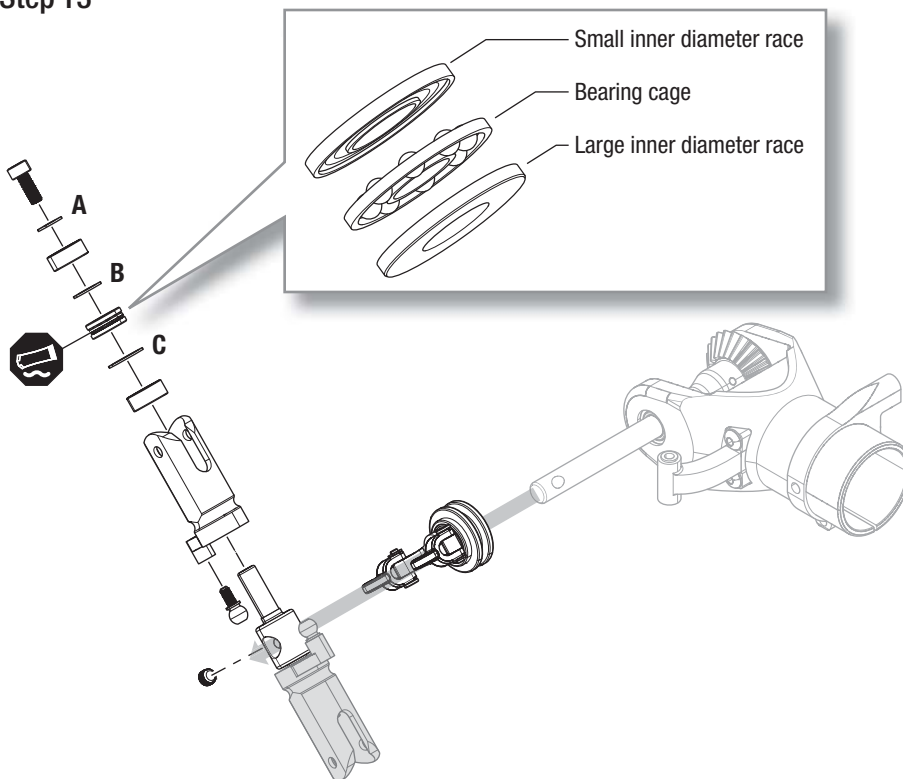





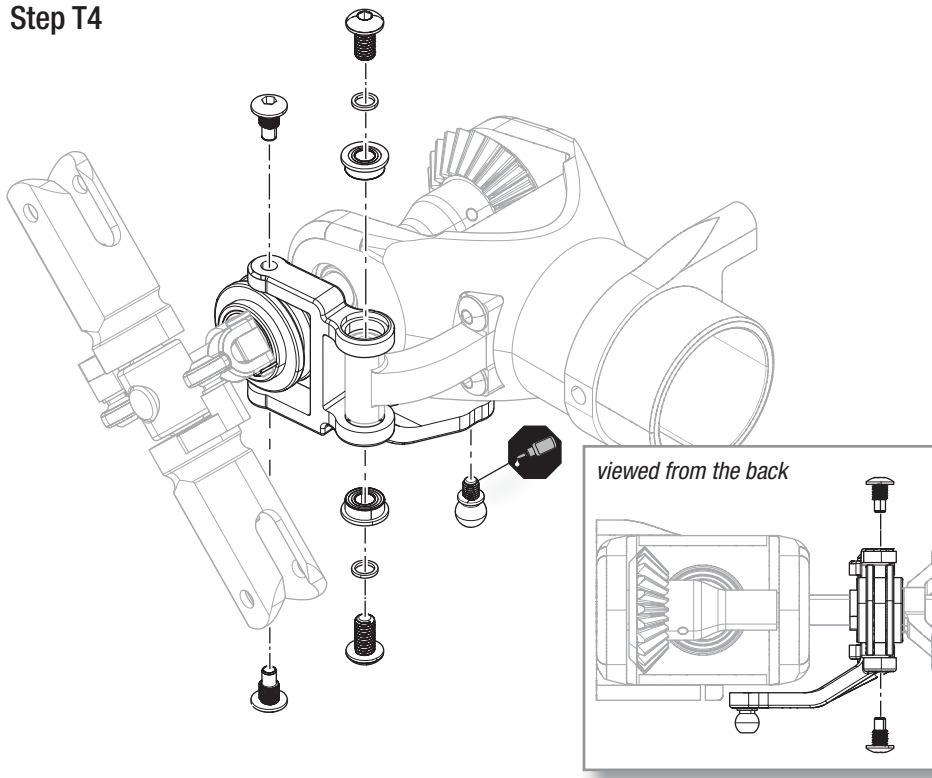



Tail assembly cont'd

Step T4





Step T4 parts (bag T4)

-  M3 X 6 Button Head Bolt (x2) 
-  Bell Crank Bolt (x2) 
-  Control Ball 
-  Flanged Bearing M3 X 6 X 2.5 (x2)
-  Washer M3 X 4 X .5 (x2)

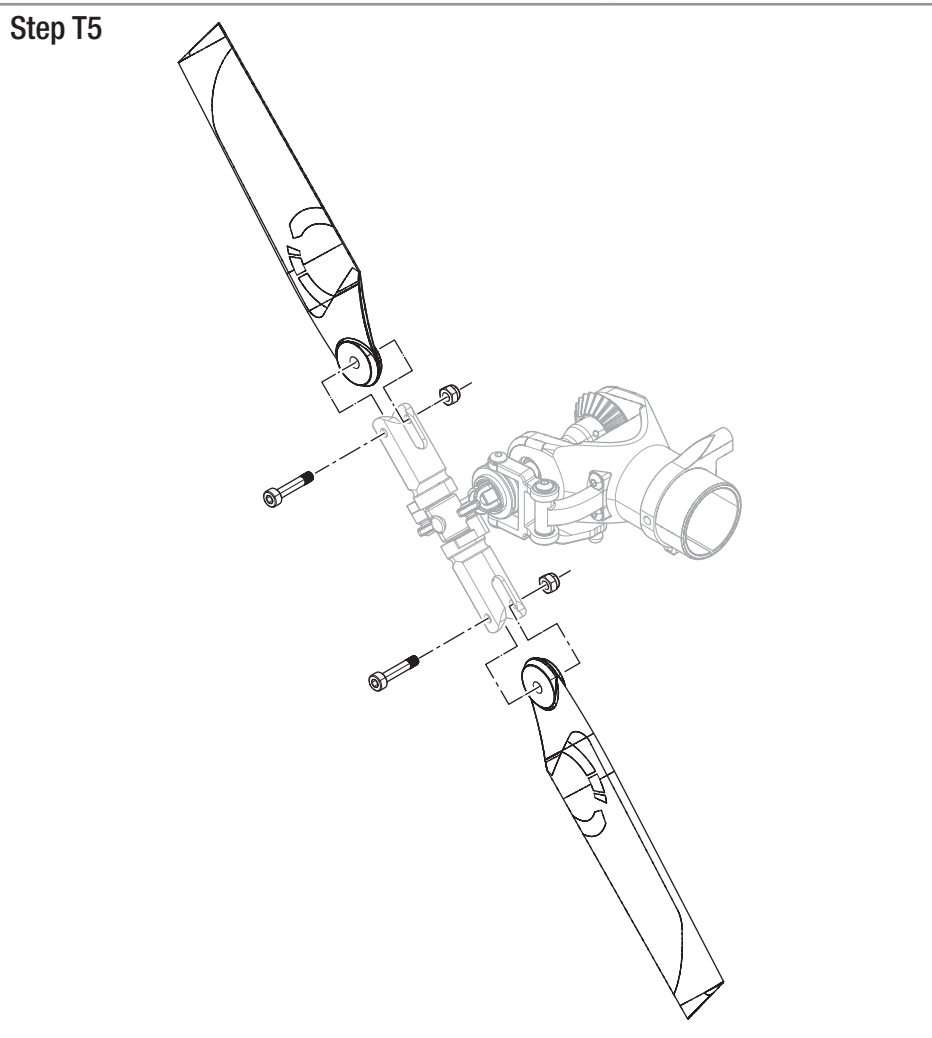
Step T5

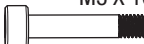

Step T5 parts (bag T3)

-  M3 X 16 Cap Head Shoulder Bolt (x2) 
-  M3 Lock Nut (x2)

Tail assembly cont'd

- Glue the torque tube bearings in place by placing a thin bead of CA on the torque tube at the given locations (278mm, 300mm), then slide the bearings onto the CA. Do not allow CA to get into the bearings.

Step T6

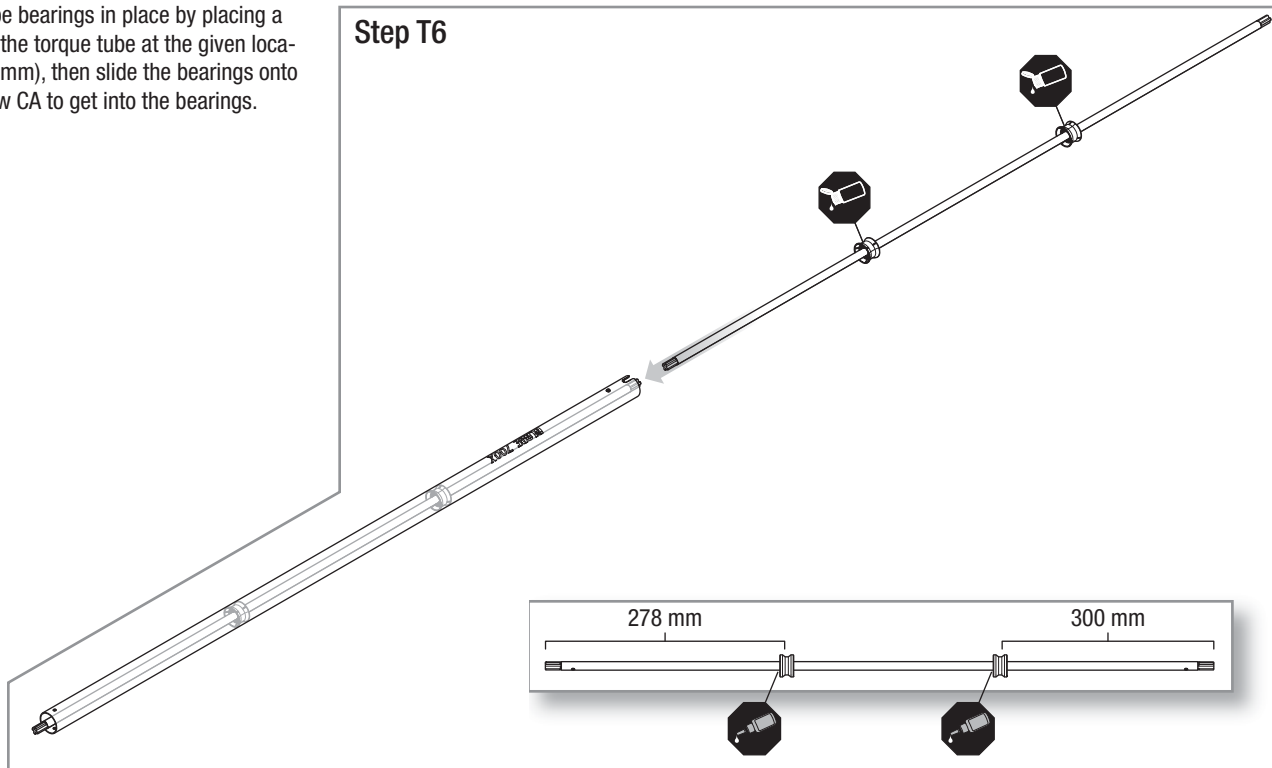

Step T7 parts (bags T5 and T6)



M3 X 12 Button Head Self-Tapping Screw (x3)



M3 X 6 Button Head Bolt (x2)



Ball Link (x2)



Tail Pushrod Guide (x3)

Step T7

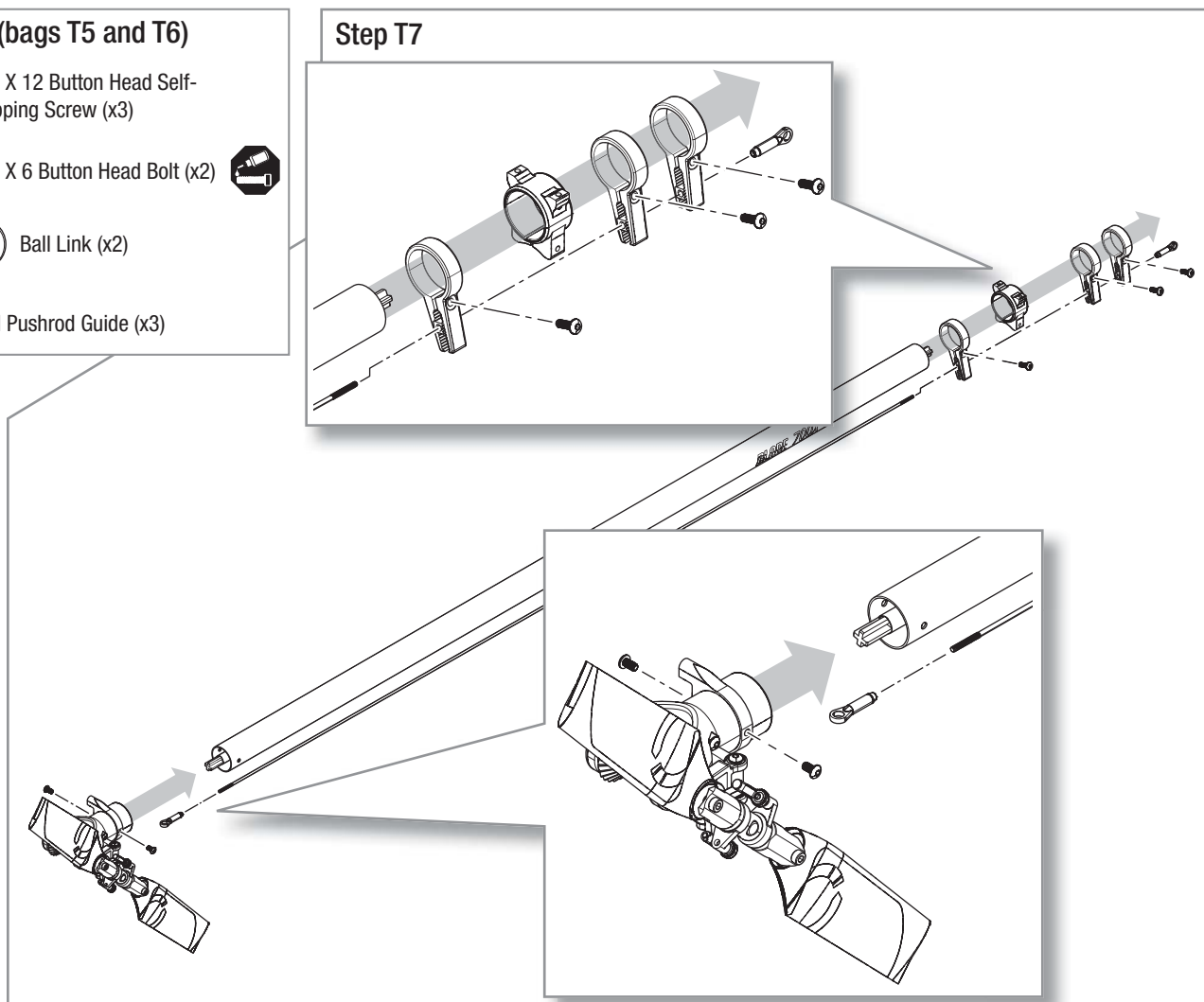











Tail assembly cont'd

Step T8







Tail Servo Neutral Position

Step T8 parts (T7, T8, and T9)

-  **A** M3 X 8 Cap Head Bolt 
-  **B** M4 X 8 Low Cap Head Bolt 
-  **C** M3 X 6 Button Head Bolt (x2) 
-  **D** M3 X 25 Cap Head Shoulder Bolt (x4) 
-  **E** M3 X 28 Cap Head Shoulder Bolt 
-  M3 Lock Nut (x4)







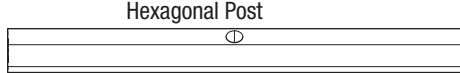

• The tail servo horn and pushrod linkage must be assembled before mounting the servo horn. Thread the ball link onto pushrod, insert the control ball into the link and then thread the 2 X 12mm machine screw through the servo horn and control ball. Set the tail servo for the neutral position, then install the servo horn onto the servo splines so the servo horn is 90° to the pushrod at neutral.

Tail Servo Horn Install

-  M3 X 8 Cap Head Bolt 
-  M2 X 12 Button Head Bolt 
-  M2 Nut
-  Servo Control Ball
-  Servo Horn

Step T9

Step T9 parts (bag T10)

-  Hexagonal Post
-  **A** M3 X 22 Cap Head Shoulder Bolt 
-  **B** M3 X 16 Cap Head Bolt (x2) 
-  **C** M3 X 12 Cap Head Bolt 
-  M3 Washer (x4)
-  Frame Insert Spacer (x2)

ESC and Battery Tray Assembly

Step ESC parts (bag F10)

Hexagonal Post (x2)

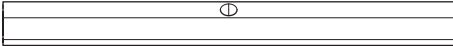

Battery Tray Post (x2)



M3 X 8 Cap Head Bolt (x6)



M2.5 X 6 Counter Sunk Bolt (x2)



M3 X 14 Button Head Bolt (x2)

OR



M3 X 14 Cap Head Bolt (x2)

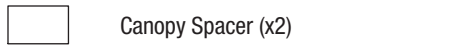

Canopy Spacer (x2)



Rubber Canopy Standoff (x2)

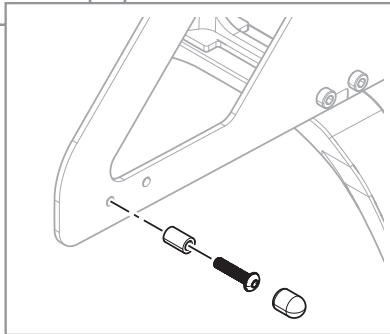
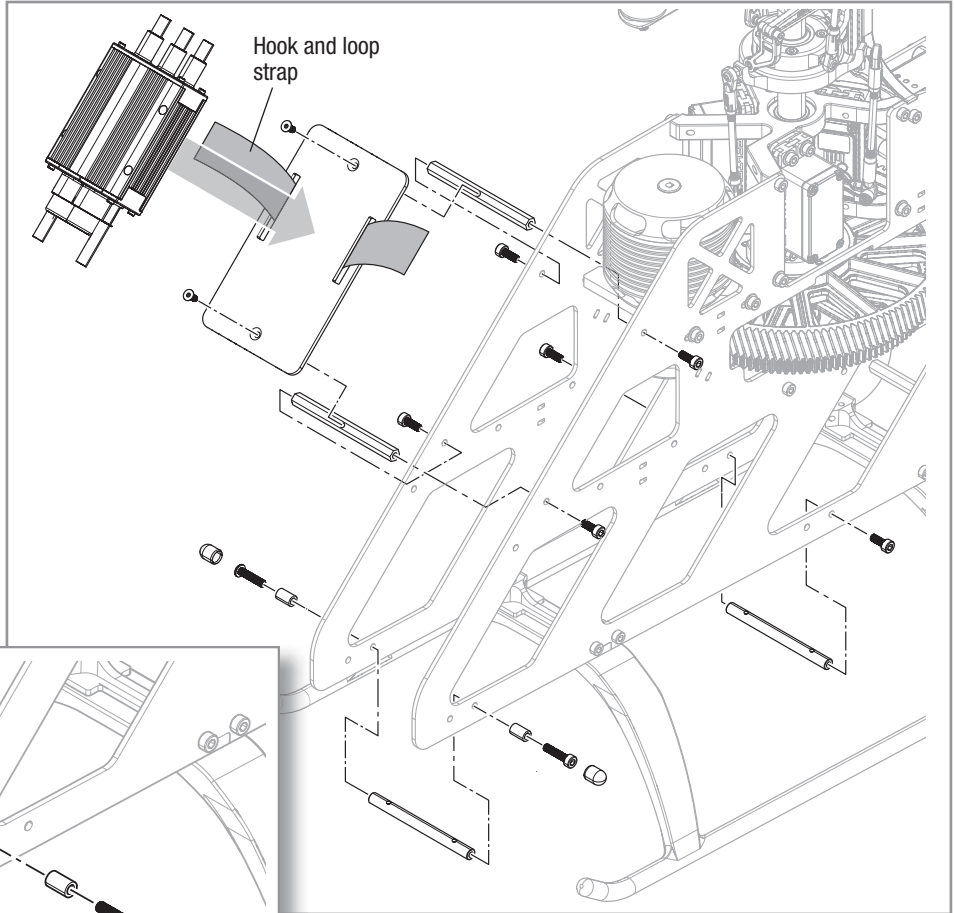

- The battery tray has forward and rear mounting locations to accommodate your equipment selection. Most of the equipment we've used has worked best with the rear mounting location to achieve the correct center of gravity. Install both battery support posts in either the front or rear location. The front support post uses a button head screw for the forward position and a cap head screw for the rear location to best fit the canopy.

Battery Tray parts (bag B1)



M3 X 8 Counter Sunk Screw (x8)



M4 X 12 Cap Head Bolt (x2)



M2 X 8 Cap Head Screw (x2)



Spacer 4 X 5 X 3 (x2)



Spring (x2)

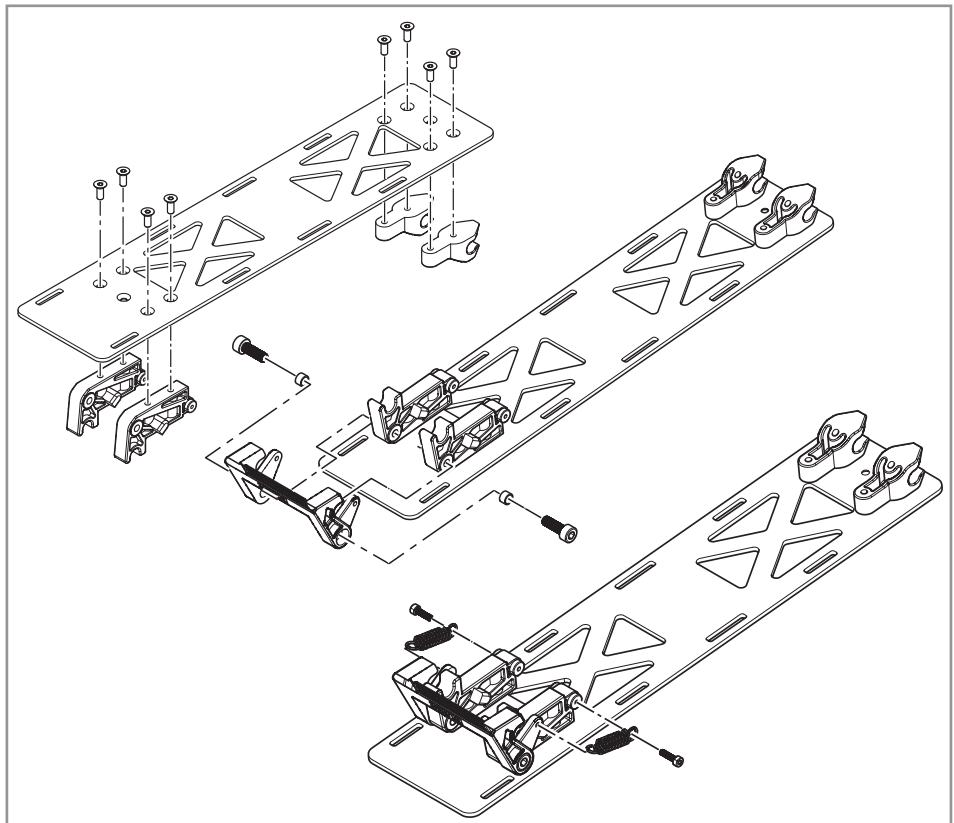

ESC and Battery Tray Assembly cont'd

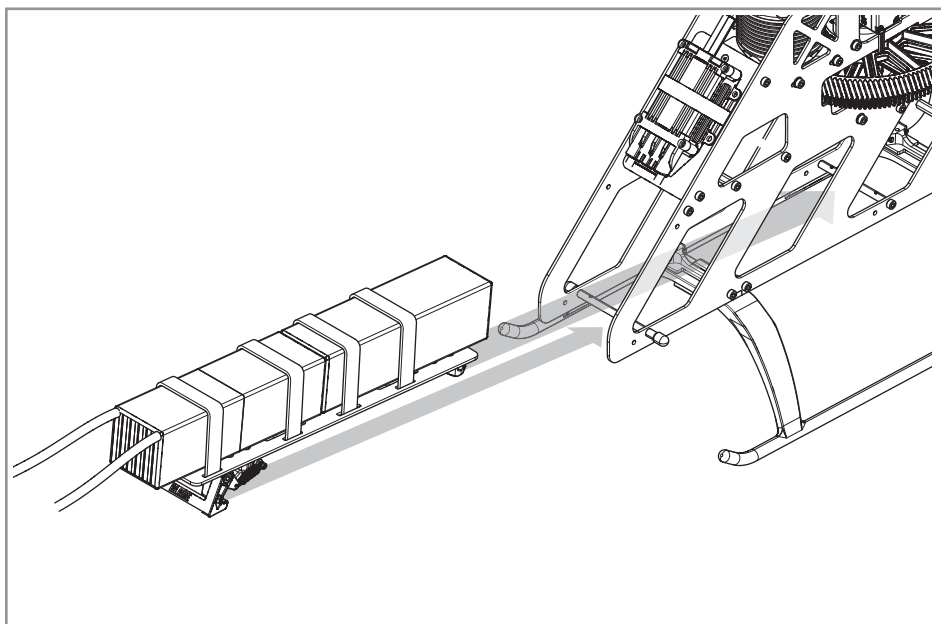
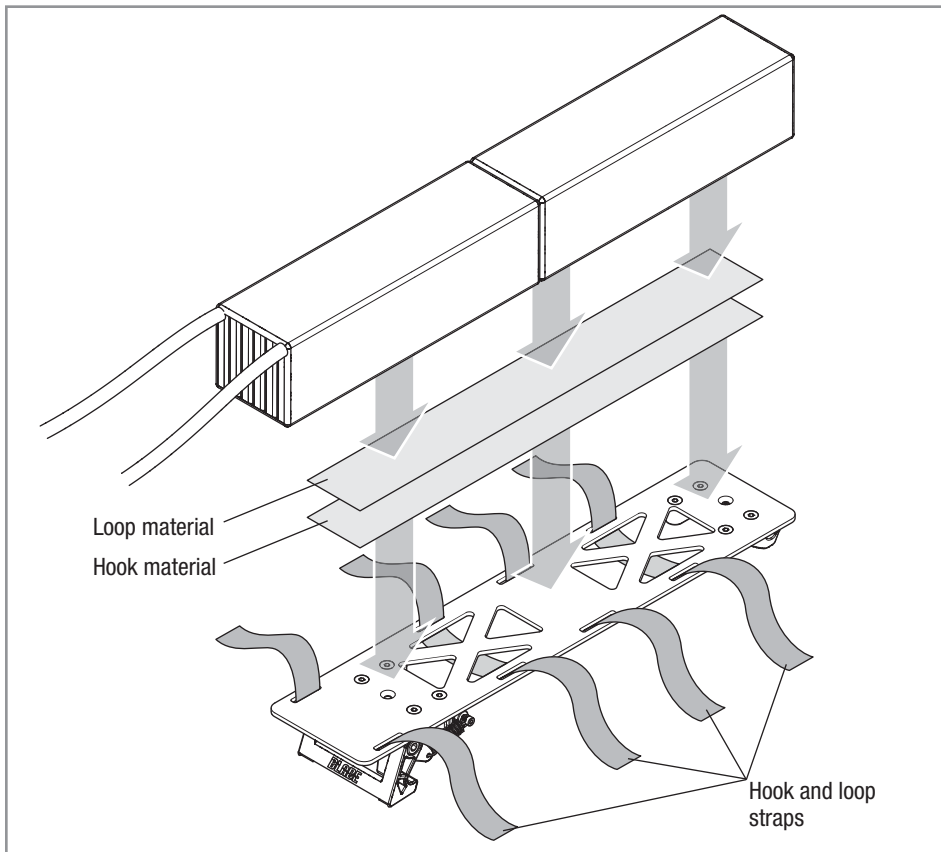

Main Rotor Installation

Main Rotor parts (bag H3)

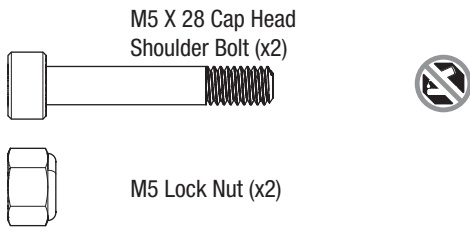

- The rotor blades should be tight enough to hold their position if you hold the helicopter sideways, but loose enough to swing freely if you move the helicopter and stop abruptly.

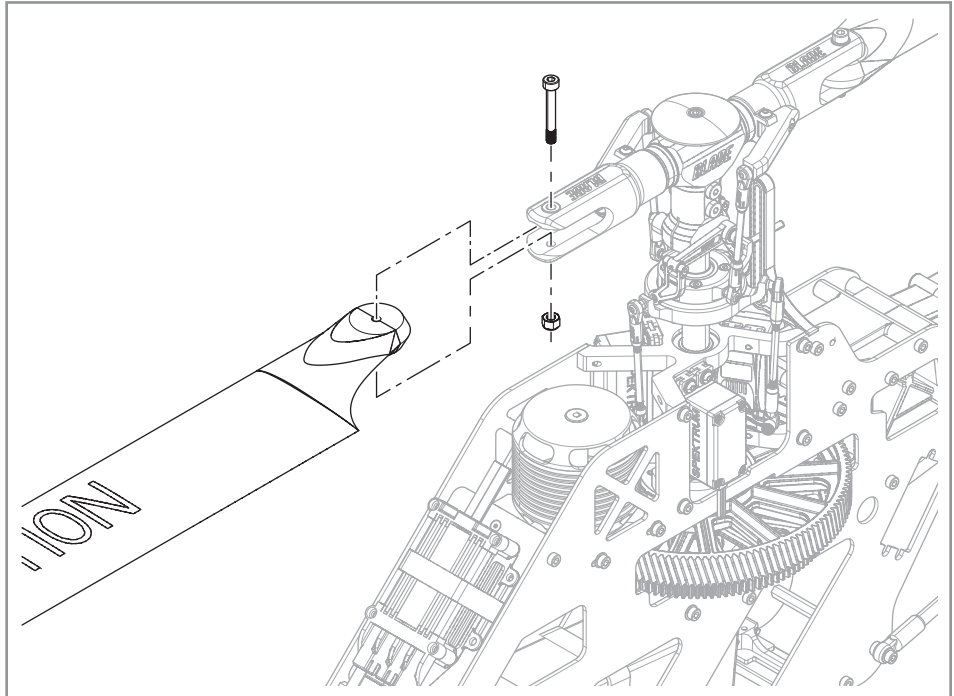

Programming Your Transmitter

Refer to your FBL controller and transmitter manuals for proper setup.

Programming instructions for the *E-flite* 100-Amp, HV brushless ESC (EFLA2100) included with the combo kit can be found online at www.horizonhobby.com. The EFLA2100 is preprogrammed at the factory. Please use the throttle curves given below for the factory default programming.

Throttle Curve					
NORM	0%	25%	25%	25%	25%
ST-1	75%	75%	75%	75%	75%
ST-2	100%	100%	100%	100%	100%

Throttle Hold

When you move the throttle hold switch to the ON position, the helicopter motor turns off. You will still have control of the helicopter cyclic and rudder commands.

You should also turn throttle hold ON to minimize damage if the helicopter is out of control or in danger of crashing.

The blades spin if throttle hold is OFF. For safety, turn throttle hold ON any time you need to touch the helicopter or check the direction controls.

See your transmitter manual for more information on programming throttle hold.

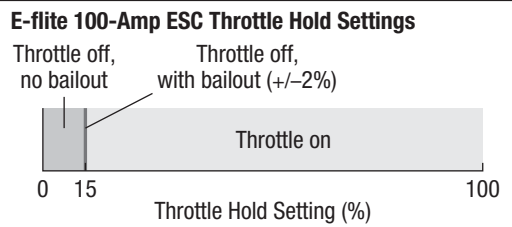

AR7200BX Parameter Menu Tips

Refer to the Spektrum AR7200BX manual to fine tune the Blade 700 X to your flying and control style via the AR7200BX parameter menu.

If you would like to have the cyclic behavior to feel more linear OR more like a flybarred helicopter, increase the cyclic response by adjusting parameter G (default is 'normal').

If you would like to change the control behavior of the flybarless system to a pre-defined behavior in the AR7200BX, adjust parameter B (default behavior is transmitter).

Refer to the Spektrum AR7200BX manual for specific details on each parameter.

Motor Direction Test

Place the helicopter outdoors on a clean, flat and level surface (concrete or asphalt) free of obstructions. Always stay clear of moving rotor blades.

1. Power on the transmitter. Make sure TH HOLD is ON and the flight mode switch is in the normal position.

 **WARNING:** The motor will spin when throttle is increased and TH HOLD is OFF.

2. Lower the throttle completely.

 **WARNING:** Stay at least 45 feet (13 meters) away from the helicopter when the motor is running.

3. Connect the Li-Po battery to the ESC.

4. Turn TH HOLD OFF. Slowly increase the throttle until the drive train begins to turn. The main blades spin clockwise when viewing the helicopter from the top. The tail rotor blades spin counterclockwise when viewing the helicopter from the right-hand side.

NOTICE: If the drive train does not turn with the motor or spins counterclockwise, turn TH HOLD ON. Disconnect the battery from the helicopter and reverse any two motor wire connections to the ESC and repeat the motor control test.

Low Voltage Cutoff (LVC)

Low voltage cutoff (LVC) protects the Li-Po battery from overdischarge in flight and activates when the battery reaches 3V per cell under load.

Set your transmitter timer for 4 minutes and land when the timer expires.

Repeatedly flying to LVC will damage the flight battery and require you to replace the battery.

Crash damage and battery damage are not covered under warranty.

Always disconnect and remove the Li-Po battery from the aircraft after each flight. Charge your Li-Po battery to about half capacity before storage. During storage, make sure battery charge does not fall below 3V per cell. A connected battery will result in trickle discharge.

Flight Guidelines and Warnings

- Always keep aircraft in sight and under control.
- Always keep people and pets at least 45 feet (13 meters) away when the battery is connected.
- Keep children out of the vicinity of this product at all times.
- Always turn on throttle hold at rotor strike.
- Always use fully charged batteries.
- Always keep transmitter powered on while aircraft is powered.
- Always remove batteries before disassembly.
- Always keep moving parts clean.
- Always keep parts dry.
- Always let parts cool after use before touching.
- Always remove batteries after use.
- Always have a first aid kit with you.
- Always have an appropriate fire extinguisher with you.
- Never operate aircraft with damaged wiring.
- Never touch moving parts.

Flying Your 700 X

Consult local laws and ordinances before choosing a location to fly your aircraft.

Select a large, open area away from people and objects. Your first flights should be outdoors in low-wind conditions. Always stay at least 45 feet (13 meters) away from the helicopter when it is flying.

Do not attempt to fly the Blade 700 X indoors.

 **CAUTION:** The Blade 700 X is intended for pilots with experience flying aerobatic, collective pitch helicopters. The Blade 700 X is more responsive than other Blade helicopters. If you are not an experienced 3D or collective pitch helicopter pilot, do not attempt to fly this product.

Takeoff

Gradually increase the throttle, allowing the rotors time to come up to speed.

 **CAUTION:** Do not give any aileron, elevator or rudder commands before the helicopter lifts off. Any control inputs prior to liftoff could cause a crash.

The helicopter will lift off the ground when the rotor head reaches a suitable speed and you apply collective pitch. Once airborne, establish a low-level hover to verify everything is functioning properly. DO NOT use trim to assist in holding the Blade 700X in a desired position. The AR7200BX Flybarless Stabilization System renders trim unnecessary by working to keep the helicopter in whatever attitude you command with the control sticks.

Flying

This aircraft is extremely sensitive to control inputs. We recommend you fly at low rate settings for the first few flights until you are familiar with its response. For pilots new to collective pitch helicopters, familiarize yourself with your Blade 700 X in normal mode and at low rate.

 **CAUTION:** Always fly the helicopter with your back to the sun and wind to prevent loss of flight control.

Landing

Establish a low level hover. Deliberately lower the throttle until the helicopter lands. Make only small control corrections during this time to avoid rotor blade strikes or other damage.

When the helicopter is in stunt mode:

- The rotor head speed is constant.
- The main rotor will increase negative pitch as the throttle/collective stick is moved from the middle stick position to the low stick position. Negative pitch allows the helicopter to fly upside down and perform aerobatics.

Change between stunt and normal modes in a hover with the throttle near the hovering stick position.

The helicopter may go up or down when you change between modes due to the difference in the throttle and pitch curves.

NOTICE: To minimize damage, always activate throttle hold in preparation for or during a crash.

 **WARNING:** Only use Blade 700 X approved carbon fiber main blades. Do not use wooden main blades with the Blade 700 X. Using wooden main blades may cause injury or property damage.

As you become more familiar with the helicopter's response, adjust the rates, expo, pitch and throttle curves to suit your flying style.

Blade Tracking

WARNING: Always maintain a safe distance of at least 13 meters (45 feet) when checking the main rotor blade tracking.

To check the blade tracking:

1. Put the helicopter in a hover at an altitude near eye height.

2. Watch the movement at the blade tips. Both blades should travel in the same plane.
3. If one blade tip appears to be higher than the other, land the helicopter, disconnect the flight battery and adjust the blade linkages.
4. Repeat Steps 1 through 3 until both blades are moving in the same plane.

Adjusting the Rudder Gyro Gain

- If the tail wags or oscillates, lower the gain on the gyro.

On your transmitter's gyro menu, decrease the gyro gain values a small amount at a time until the helicopter is stable within a particular flight mode

- If the tail is drifting while hovering, increase the gain on the gyro.

On your transmitter, increase the gyro gain values a small amount at a time until the tail starts to wag/oscillate. Afterwards, reduce the gain until the tail stops wagging/oscillating within a particular flight mode.

Post-Flight Inspection and Maintenance Checklist

✓		✓	
Ball Links	Make sure the plastic ball link holds the control ball, but is not tight (binding) on the ball. When a link is too loose on the ball, it can separate from the ball during flight and cause a crash. Replace worn ball links before they fail.	Rotors	Make sure there is no damage to rotor blades and other parts which move at high speed. Damage to these parts includes cracks, burrs, chips or scratches. Replace damaged parts before flying.
Cleaning	Make sure the battery is not connected before cleaning. Remove dust and debris with a soft brush or a dry lint-free cloth.	Gyro	Make sure the AR7200BX is securely attached to the frame. Replace the double-sided tape when necessary. The helicopter will crash if the AR7200BX separates from the helicopter frame.
Bearings	Replace bearings when they become notchy (sticky in places when turning) or draggy.	Gearing	Make sure the gears are all in good condition. Watch for chipped teeth or excessive wear. White dust around gears is an indication of excess wear. Replace damaged gears before flying.
Wiring	Make sure wiring does not block moving parts. Replace damaged wiring and loose connectors.		
Fasteners	Make sure there are no loose screws, other fasteners or connectors. Do not over tighten metal screws in plastic parts. Tighten screw so parts are mated together, then turn screw only 1/8th of a turn more.		

AR7200BX Fine-tuning and Adjustment

Observed Behavior	Suggested Adjustment
Cyclic response is too slow or too fast	Adjust end points to fit your flying style. Refer to your transmitter instruction manual for more information
	Adjust the control behavior parameter in the AR7200BX to fit your flying style.
Control inputs feel delayed	Increase Dial 2 on the AR7200BX
The helicopter seems to overshoot control input and then return	Decrease Dial 2 on the AR7200BX
The helicopter tail stops too abruptly	Decrease Dial 3 on the AR7200BX
The helicopter tail does not stop precisely	Increase the rudder gain in your transmitter
	Increase Dial 3 on the AR7200BX
	Adjust the rudder heading lock gain parameter in the AR7200BX

Blade 700 X Troubleshooting Guide

Problem	Possible Cause	Solution
AR7200BX will not initialize	The helicopter was moved during initialization	Lay the helicopter on its side during initialization if windy
	The transmitter is powered off	Power on the transmitter
	Controls are not centered	Center elevator, aileron and rudder controls. Make sure the throttle is at idle
LED on receiver flashes rapidly and aircraft will not bind to transmitter (during binding)	Transmitter is too near aircraft during binding process	Power off transmitter, move transmitter a larger distance from aircraft, disconnect and reconnect flight battery to aircraft and follow binding instructions
	Bind switch or button was not held while transmitter was powered on	Power off transmitter and repeat bind process
	Aircraft or transmitter is too close to large metal object, wireless source or another transmitter	Move aircraft and transmitter to another location and attempt binding again
LED on receiver flashes rapidly and aircraft will not respond to transmitter (after binding)	Less than a 5-second wait between first powering on transmitter and connecting flight battery to aircraft	Leaving transmitter on, disconnect and reconnect flight battery to aircraft
	Aircraft is bound to a different model memory (<i>ModelMatch™</i> radios only)	Select correct model memory on transmitter and disconnect and reconnect flight battery to aircraft
	Flight battery/transmitter battery charge is too low	Replace/recharge batteries
	Transmitter may have been bound to a different model (or with a different <i>DSM</i> Protocol)	Select the right transmitter or bind to the new one
Helicopter will not respond to the throttle but responds to other controls	Aircraft or transmitter is too close to large metal object, wireless source or another transmitter	Move aircraft and transmitter to another location and attempt connecting again
	Throttle not at idle and/or throttle trim is too high	Lower the throttle stick and lower the throttle trim
	The transmitter is not in normal mode or throttle hold is on	Make sure the transmitter is in normal mode and throttle hold is off
	The motor is not connected to the ESC or the motor wires are damaged	Connect the motor wires to the ESC and check motor wires for damage
	Flight battery charge is too low	Replace or recharge flight battery
Helicopter power is lacking	Throttle channel is reversed	Reverse the throttle channel on the transmitter
	Flight battery has low voltage	Fully charge the flight battery
	Flight battery is old or damaged	Replace the flight battery
Helicopter will not lift off	Flight battery cells are unbalanced	Fully charge the flight battery, allowing the charger time to balance the cells
	Transmitter settings are not correct	Check throttle and pitch curve settings and pitch control direction
	Flight battery has low voltage	Fully charge the flight battery
The helicopter tail spins out of control	Main rotor blades are installed backwards	Install the main rotor blades with the thicker side as the leading edge
	Rudder control and/or sensor direction reversed	Make sure the rudder control and the rudder sensor are operating in the correct direction
	Tail servo is damaged	Check the rudder servo for damage and replace if necessary
	Tail drive gears are damaged	Replace damaged gears.
	Inadequate control arm throw	Check the rudder control arm for adequate travel and adjust if necessary
The helicopter wobbles in flight	Torque tube is not fully engaged in tail gears.	Ensure the tail boom and tail gear box are fully seated. Confirm tail pushrod length and tail settings on AR7200BX are correct after making any changes.
	Cyclic gain is too high	Decrease Dial 1 on the AR7200BX
	Headspeed is too low	Increase the helicopter's head speed via your transmitter settings and/or using a freshly charged flight pack
	Dampers are worn	Replace the main rotor head dampers

Limited Warranty

What this Warranty Covers

Horizon Hobby, Inc., (Horizon) warrants to the original purchaser that the product purchased (the "Product") will be free from defects in materials and workmanship at the date of purchase.

What is Not Covered

This warranty is not transferable and does not cover (i) cosmetic damage, (ii) damage due to acts of God, accident, misuse, abuse, negligence, commercial use, or due to improper use, installation, operation or maintenance, (iii) modification of or to any part of the Product, (iv) attempted service by anyone other than a Horizon Hobby authorized service center, (v) Product not purchased from an authorized Horizon dealer, or (vi) Product not compliant with applicable technical regulations.

OTHER THAN THE EXPRESS WARRANTY ABOVE, HORIZON MAKES NO OTHER WARRANTY OR REPRESENTATION, AND HEREBY DISCLAIMS ANY AND ALL IMPLIED WARRANTIES, INCLUDING, WITHOUT LIMITATION, THE IMPLIED WARRANTIES OF NON-INFRINGEMENT, MERCHANTABILITY AND FITNESS FOR A PARTICULAR PURPOSE. THE PURCHASER ACKNOWLEDGES THAT THEY ALONE HAVE DETERMINED THAT THE PRODUCT WILL SUITABLY MEET THE REQUIREMENTS OF THE PURCHASER'S INTENDED USE.

Purchaser's Remedy

Horizon's sole obligation and purchaser's sole and exclusive remedy shall be that Horizon will, at its option, either (i) service, or (ii) replace, any Product determined by Horizon to be defective. Horizon reserves the right to inspect any and all Product(s) involved in a warranty claim. Service or replacement decisions are at the sole discretion of Horizon. Proof of purchase is required for all warranty claims. SERVICE OR REPLACEMENT AS PROVIDED UNDER THIS WARRANTY IS THE PURCHASER'S SOLE AND EXCLUSIVE REMEDY.

Limitation of Liability

HORIZON SHALL NOT BE LIABLE FOR SPECIAL, INDIRECT, INCIDENTAL OR CONSEQUENTIAL DAMAGES, LOSS OF PROFITS OR PRODUCTION OR COMMERCIAL LOSS IN ANY WAY, REGARDLESS OF WHETHER SUCH CLAIM IS BASED IN CONTRACT, WARRANTY, TORT, NEGLIGENCE, STRICT LIABILITY OR ANY OTHER THEORY OF LIABILITY, EVEN IF HORIZON HAS BEEN ADVISED OF THE POSSIBILITY OF SUCH DAMAGES. Further, in no event shall the liability of Horizon exceed the individual price of the Product on which liability is asserted. As Horizon has no control over use, setup, final assembly, modification or misuse, no liability shall be assumed nor accepted for any resulting damage or injury. By the act of use, setup or assembly, the user accepts all resulting liability. If you as the purchaser or user are not prepared to accept the liability associated with the use of the Product, purchaser is advised to return the Product immediately in new and unused condition to the place of purchase.

Law

These terms are governed by Illinois law (without regard to conflict of law principals). This warranty gives you specific legal rights, and you may also have other rights which vary from state to state. Horizon reserves the right to change or modify this warranty at any time without notice.

WARRANTY SERVICES

Questions, Assistance, and Services

Your local hobby store and/or place of purchase cannot provide warranty support or service. Once assembly, setup or use of the Product has been started, you must contact your local distributor or Horizon directly. This will enable Horizon to better answer your questions and service you in the event that you may need any assistance. For questions or assistance, please visit our website at www.horizonhobby.com, submit a Product Support Inquiry, or call the toll free telephone number referenced in the Warranty and Service Contact Information section to speak with a Product Support representative.

Inspection or Services

If this Product needs to be inspected or serviced and is compliant in the country you live and use the Product in, please use the Horizon Online Service Request submission process found on our website or call Horizon to obtain a Return Merchandise Authorization (RMA) number. Pack the Product securely using a shipping carton. Please note that original boxes may be included, but are not designed to withstand the rigors of shipping without additional protection. Ship via a carrier that provides tracking and insurance for lost or damaged parcels, as Horizon is not responsible for merchandise until it arrives and is accepted at our facility. An Online Service Request is available at http://www.horizonhobby.com/content/_service-center_render-service-center. If you do not have internet access, please contact Horizon Product Support to obtain a RMA number along with instructions for submitting your product for service. When calling Horizon, you will be asked to provide your complete name, street address, email address and phone number where you can be reached during business hours. When sending product into Horizon, please include your RMA number, a list of the included items, and a brief summary of the problem. A copy of your original sales receipt must be included for warranty consideration. Be sure your name, address, and RMA number are clearly written on the outside of the shipping carton.

NOTICE: Do not ship LiPo batteries to Horizon. If you have any issue with a LiPo battery, please contact the appropriate Horizon Product Support office.

Warranty Requirements

For Warranty consideration, you must include your original sales receipt verifying the proof-of-purchase date. Provided warranty conditions have been met, your Product will be serviced or replaced free of charge. Service or replacement decisions are at the sole discretion of Horizon.

Non-Warranty Service

Should your service not be covered by warranty, service will be completed and payment will be required without notification or estimate of the expense unless the expense exceeds 50% of the retail purchase cost. By submitting the item for service you are agreeing to payment of the service without notification. Service estimates are available upon request. You must include this request with your item submitted for service. Non-warranty service estimates will be billed a minimum of ½ hour of labor. In addition you will be billed for return freight. Horizon accepts money orders and cashier's checks, as well as Visa, MasterCard, American Express, and Discover cards. By submitting any item to Horizon for service, you are agreeing to Horizon's Terms and Conditions found on our website http://www.horizonhobby.com/content/_service-center_render-service-center.

ATTENTION: Horizon service is limited to Product compliant in the country of use and ownership. If received, a non-compliant Product will not be serviced. Further, the sender will be responsible for arranging return shipment of the un-serviced Product, through a carrier of the sender's choice and at the sender's expense. Horizon will hold non-compliant Product for a period of 60 days from notification, after which it will be discarded.

Warranty and Service Contact Information

Country of Purchase	Horizon Hobby	Contact Information	Address
United States of America	Horizon Service Center (Repairs and Repair Requests)	servicecenter.horizonhobby.com/RequestForm/	4105 Fieldstone Rd Champaign, Illinois, 61822 USA
	Horizon Product Support (Product Technical Assistance)	www.quickbase.com/db/ bghj7ey8c?a=GenNewRecord 888-959-2304	
	Sales	sales@horizonhobby.com 888-959-2304	
United Kingdom	Service/Parts/Sales: Horizon Hobby Limited	sales@horizonhobby.co.uk +44 (0) 1279 641 097	Units 1-4 , Ployters Rd, Staple Tye Harlow, Essex, CM18 7NS, United Kingdom
Germany	Horizon Technischer Service	service@horizonhobby.de	Christian-Junge-Straße 1 25337 Elmshorn, Germany
	Sales: Horizon Hobby GmbH	+49 (0) 4121 2655 100	
France	Service/Parts/Sales: Horizon Hobby SAS	infofrance@horizonhobby.com +33 (0) 1 60 18 34 90	11 Rue Georges Charpak 77127 Lieusaint, France
China	Service/Parts/Sales: Horizon Hobby – China	info@horizonhobby.com.cn +86 (021) 5180 9868	Room 506, No. 97 Changshou Rd. Shanghai, China 200060

Compliance Information for the European Union

Declaration of Conformity

(in accordance with ISO/IEC 17050-1)

No. HH2013072101

Product(s): Blade 700 X Pro Series Combo

Item Number(s): BLH5725C

The object of declaration described above is in conformity with the requirements of the specifications listed below, following the provisions of the European R&TTE Directive 1999/5/EC and European EMC Directive 2004/108/EC:

EN 301 489-1 V1.9.2: 2012

EN301 489-17 V2.1.1: 2009

EN55022:2010 + AC:2011

EN55024:2010



Signed for and on behalf of:
Horizon Hobby, Inc.
Champaign, IL USA
July 21, 2013

Robert Peak
Chief Financial Officer
Horizon Hobby, Inc.

Instructions for disposal of WEEE by users in the European Union



This product must not be disposed of with other waste. Instead, it is the user's responsibility to dispose of their waste equipment by handing it over to a designated collections point for the recycling of waste electrical and electronic equipment. The separate collection and recycling of your waste equipment at the time of disposal will help to conserve natural resources and ensure that it is recycled in a manner that protects human health and the environment. For more information about where you can drop off your waste equipment for recycling, please contact your local city office, your household waste disposal service or where you purchased the product.

Exploded View (Battery Tray) / Explosionszeichnung Akkuhalter / Vue éclatée (Platine de fixation de batterie) / Vista esplosa (Supporto batteria)

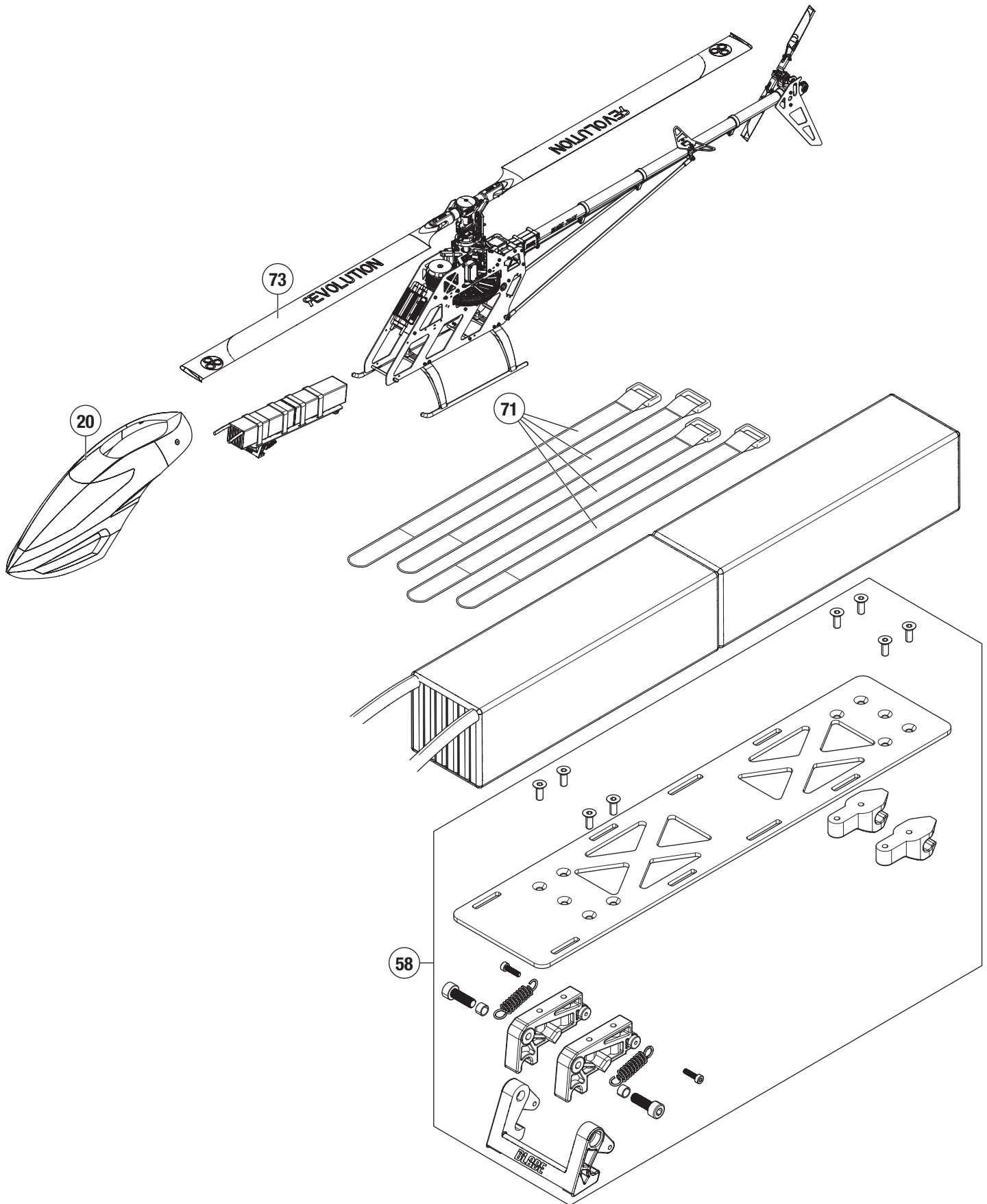

Exploded View (Head/Tailcase) / Explosionszeichnung (Rotorkopf / Heckrotorgehäuse) /
 Vue éclatée (Tête et Anticouple) / Vista esplosa (Testa/Scatola di coda)

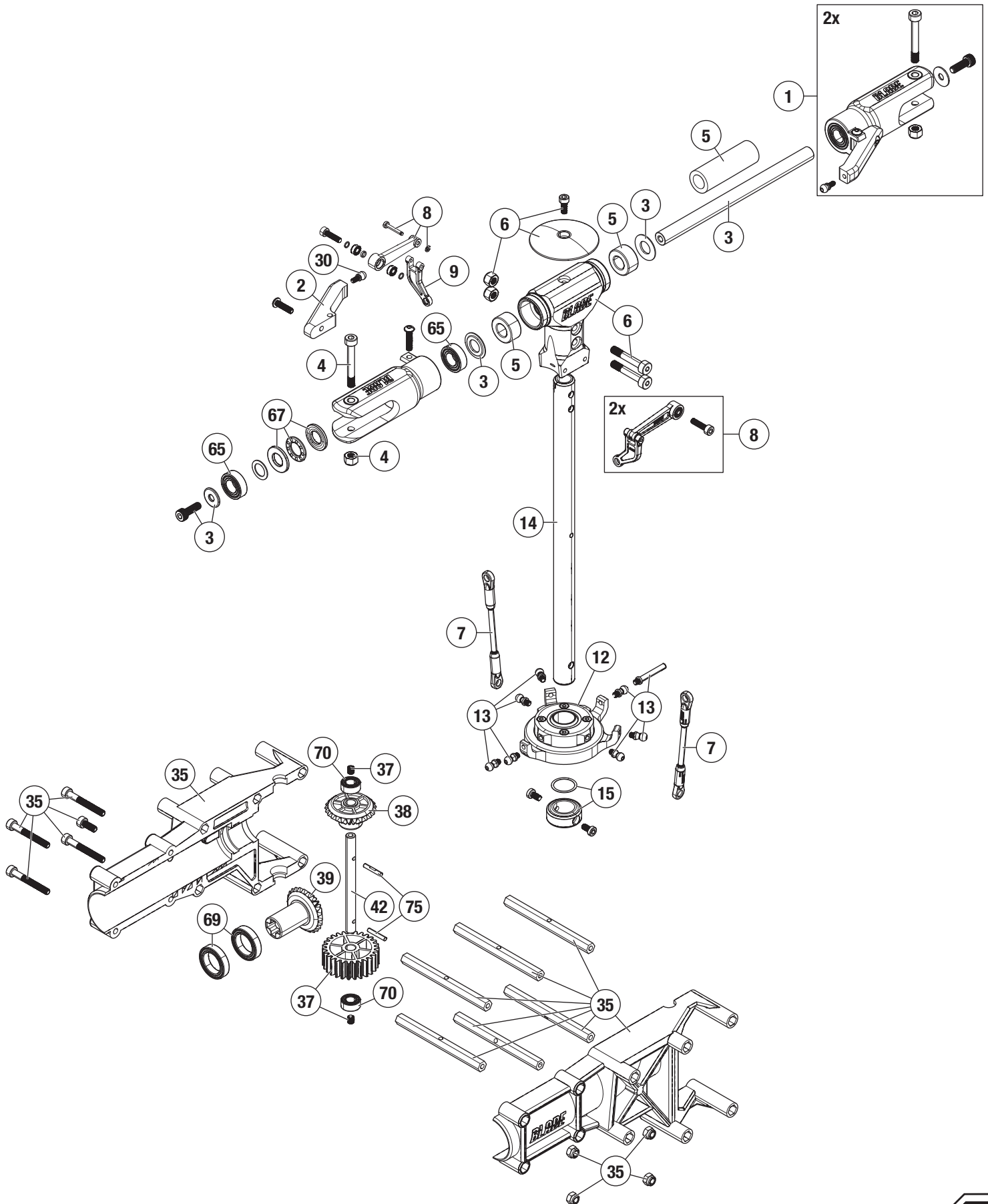

Exploded View (Frame Assembly) / Explosionszeichnung (Chassis) / Vue éclatée (Assemblage du châssis) / Vista esplosa (Gruppo telaio)

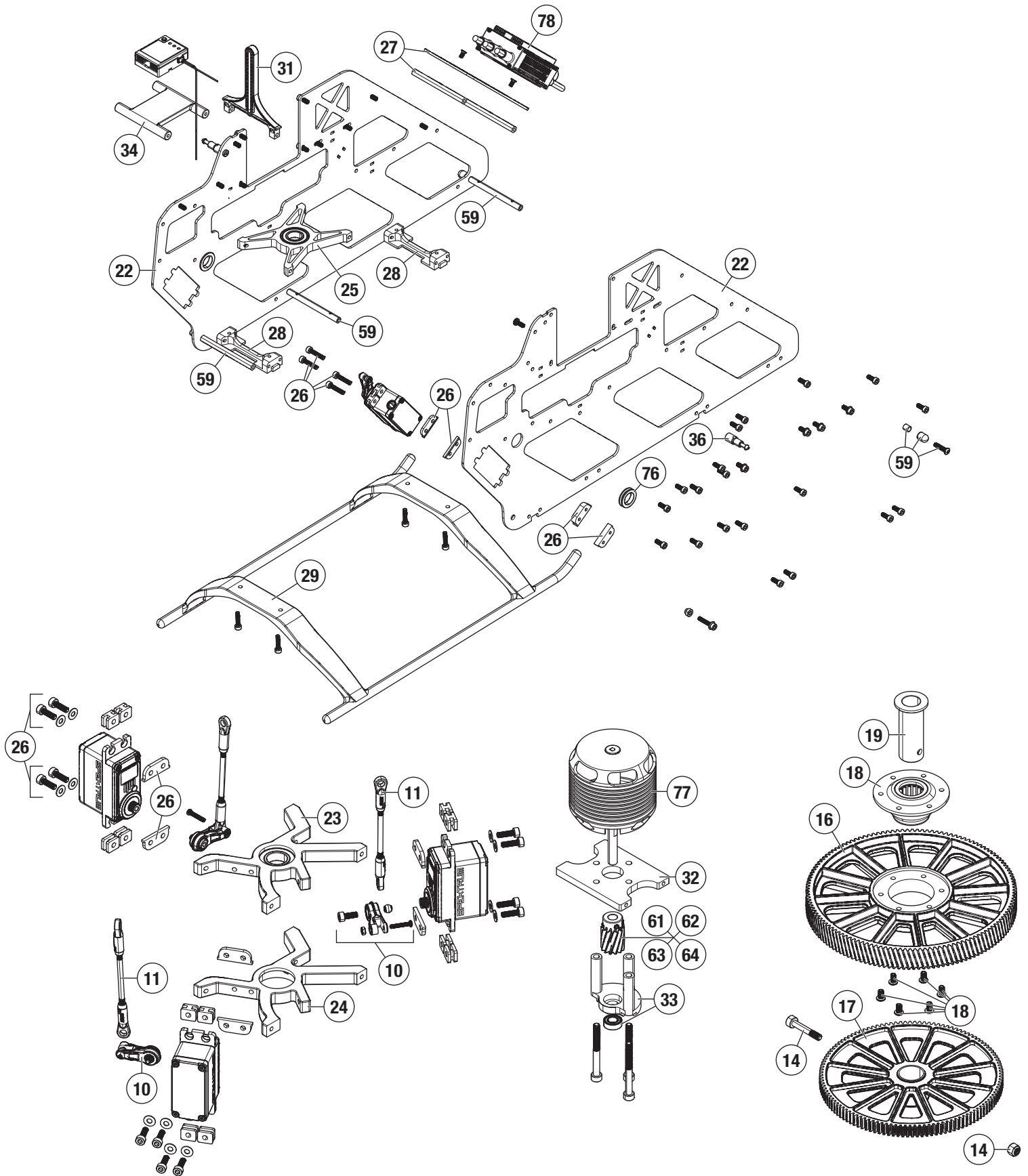

Exploded View (Tailboom Assembly) / Explosionszeichnung (Heckausleger) / Vue éclatée (Assemblage de la poutre) / Vista esplosa (Gruppo tubo coda)

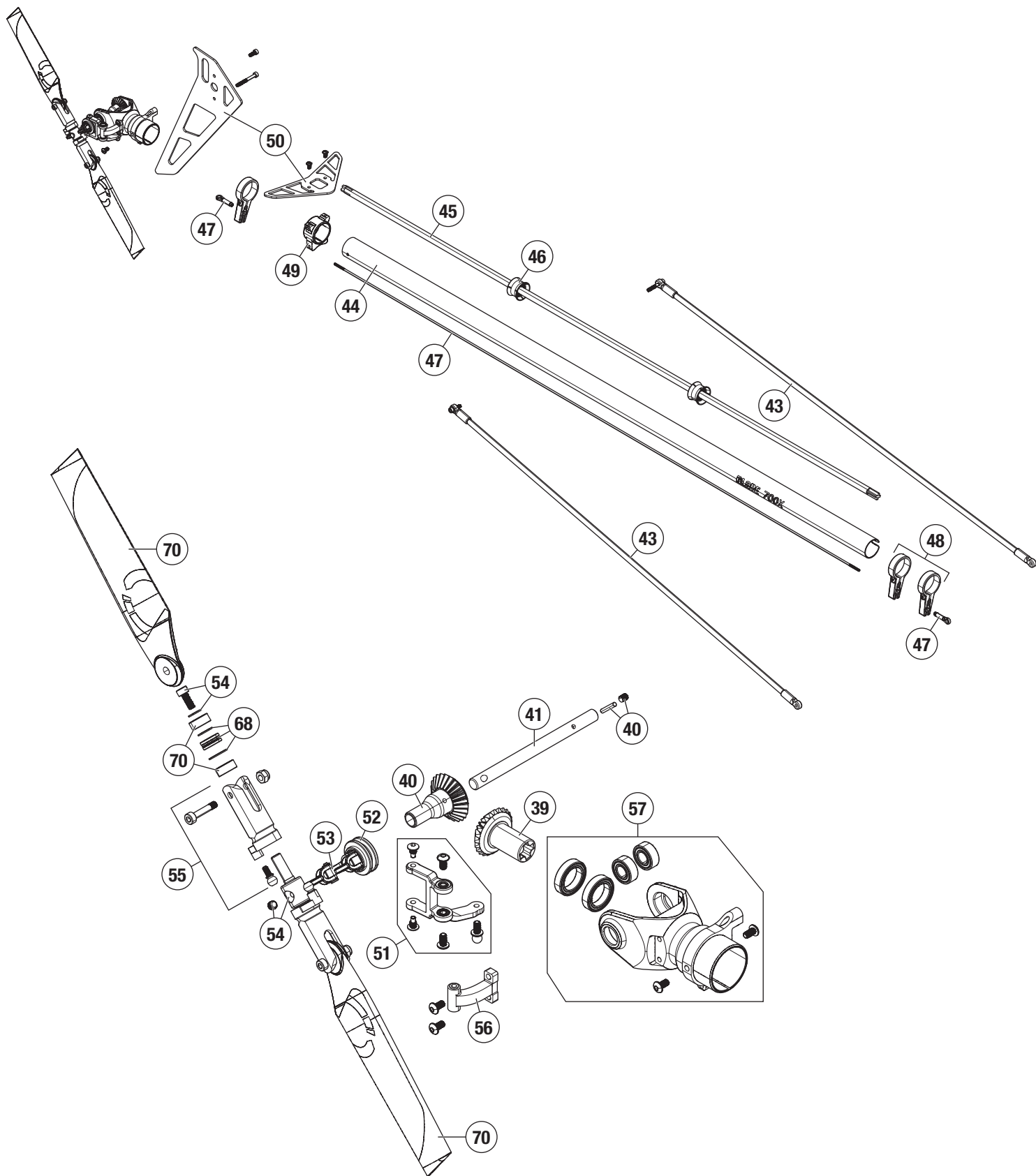

Parts List / Ersatzteile / Pièces de rechange / Pezzi di ricambio

#	Part #	English	Deutsch	Français	Italiano
1	BLH5701	Main Rotor Grip Set: 700 X	Blade 700 X: Rotorblatthalterset	700 X - Pieds de pales principales	Set portapale rotore principale: 700 X
2	BLH5702	Main Grip Arms: 700 X	Blade 700 X: Rotorblatthalterarmset	700 X - Leviers de pieds de pales principales	Braccetti portapale: 700 X
3	BLH5703	Spindle Set (2): 700 X	Blade 700 X: Blatthalterwelle (2)	700 X - Axe de pieds de pales (2)	Set alberino: 700 X
4	BLH5704	Main Rotor Blade Bolt Set (2): 700 X	Blade 700 X: Rotorblattbolzen (2)	700 X - Vis de fixations de pales principales (2)	Set viti pala rotore principale: 700 X
5	BLH5705	Dampers (4): 700 X	Blade 700 X: Dämpfer (4)	700 X - Amortisseurs (4)	Smorzatori: 700 X
6	BLH5706	Head Block: 700 X	Blade 700 X: Rotorblockkopf	700 X - Moyeu de tête	Blocco testa: 700 X
7	BLH5707	Main Rotor Head Link Set: 700 X	Blade 700 X: Anlenkungen Hauptrotorkopf	700 X - Set de tringleries de tête rotor	Set collegamenti testa rotore principale: 700 X
8	BLH5708	Follower Arms: 700 X	Blade 700 X: Taumelscheibenmitnehmer	700 X - Bras flybarless	Bracci inseguitore: 700 X
9	BLH5709	Radius Arms: 700 X	Blade 700 X: Pitchkompensator	700 X - Bras radiaux	Braccetti testa: 700 X
10	BLH5710	Servo Control Arm Set: 700 X	Blade 700 X: Servoarm Set	700 X - Set de bras de servo	Set bracci controllo servo: 700 X
11	BLH5711	Servo Control Link Set	Blade 700 X: Servonanlenkungen Set	700 X - Set de tringleries de servo	Set comandi servo: 700 X
12	BLH5712	Aluminum Swashplate: 700 X	Blade 700 X: Aluminium Taumelscheibe	700 X - Plateau cyclique en aluminium	Piatto oscillante alluminio: 700 X
13	BLH5713	Swashplate Ball Set: 700 X	Blade 700 X: Kugelköpfe Taumelscheibe Set	700 X - Set de rotules de plateau cyclique	Set sfere piatto: 700 X
14	BLH5714	Main Shaft (2): 700 X	Blade 700 X: Hauptrotorwelle	700 X - Axe principal (2)	Albero principale: 700 X
15	BLH5715	Main Shaft Retaining Collar: 700 X	Blade 700 X: Stelling f. Hauptrotorwelle	700 X - Bague de retenue de l'axe principal	Collare albero principale: 700 X
16	BLH5716	Main Gear (2): 700 X	Blade 700 X: Hauptzahnrad (2)	700 X - Couronne principale (2)	Ingranaggio principale: 700 X
17	BLH5717	Autorotation Gear (2): 700 X	Blade 700 X: Autorotationsfreilauf (2)	700 X - Couronne d'autorotation (2)	Ingranaggio autorotazione: 700 X
18	BLH5718	One-Way Bearing Hub w/One way bearing: 700 X	Blade 700 X: Freilauflager	700 X - Moyeu de roue libre avec roue libre	Cuscinetto unidirezionale c/supporto: 700 X
19	BLH5719	One-Way Bearing Sleeve: 700 X	Blade 700 X: Freilaufbuchse	700 X - Axe de roue libre	Manicotto cuscinetto unidirezionale: 700 X
20	BLH5720	Stock Canopy: 700 X	Blade 700 X: Kabinenhaube	700 X - Bulle d'origine	Capottina di serie: 700 X
21	BLH5721	Canopy Grommets: 700 X	Blade 700 X: Kabinenhaubehalter	700 X - Caoutchoucs de fixation de bulle	Gommmini capottina: 700 X
22	BLH5722	CF Main Frame (1) L or R: 700 X	Blade 700 X: Chassis (1) Links o. Rechts	700 X - Flanc de châssis en carbone (1) G ou D	CF Telaio principale (1) L o R: 700 X
23	BLH5723	Upper Bearing Block: 700 X	Blade 700 X: Lagerblock oben	700 X - Palier supérieur	Cuscinetto superiore blocco: 700 X
24	BLH5724	Bottom Servo Mount : 700 X	Blade 700 X: Servohalter unten	700 X - Support inférieur de servo	Supporto inferiore servo: 700 X
25	BLH5726	Lower Bearing Block: 700 X	Blade 700 X: Lagerblock unten	700 X - Palier inférieur	Cuscinetto inferiore blocco: 700 X
26	BLH5727	Servo Screw Set: 700 X	Blade 700 X: Servoschraubenset	700 X - Set de vis de servo	Set viti servo: 700 X
27	BLH5728	ESC Mounting Tray: 700 X	Blade 700 X: Halter f. Regler	700 X - Platine de fixation de contrôleur	Supporto ESC: 700 X
28	BLH5729	Landing Gear Mounts: 700 X	Blade 700 X: Kufenhalter	700 X - Fixations de train d'atterrissage	Supporti carrello: 700 X
29	BLH5730	Landing Gear Set: 700 X	Blade 700 X: Kufengestell	700 X - Train d'atterrissage	Set carrello: 700 X
30	BLH5731	Ball Link Set: 700 X	Blade 700 X: Kugelkopfset	700 X - Set de rotules	Set sfere comandi: 700 X
31	BLH5732	Anti-Rotation Bracket: 700 X	Blade 700 X: Taumelscheibenführung	700 X - Guide anti-rotation	Staffa anti rotazione: 700 X
32	BLH5733	Motor Mount: 700 X	Blade 700 X: Motorhalter	700 X - Support moteur	Supporto motore: 700 X
33	BLH5734	Pinion Support: 700 X	Blade 700 X: Ritzelhalter	700 X - Support de pignon	Supporto pignone: 700 X
34	BLH5735	FBL Unit Mount: 700 X	Blade 700 X: FBL Einheit Halter	700 X - Support de mode de contrôle flybarless	Supporto unità FBL: 700 X
35	BLH5736	Fr Tail Boom Case: 700 X	Blade 700 X: Heckrotorgehäuse vorne	700 X - Support de poutre de queue	Scatola coda: 700 X
36	BLH5737	Canopy Posts: 700 X	Blade 700 X: Kabinenhaubestreben	700 X - Supports de bulle	Appoggi capottina: 700 X
37	BLH5738	Tail Pinion Gear-27T: 700 X	Blade 700 X: Heckrotorrizel	700 X - Pignon d'anticouple 27T	Pignone coda: 700 X
38	BLH5739	Bevel Gear-25T: 700 X	Blade 700 X: Kegellrad 25T	700 X - Pignon conique 25T	Ingranaggio conico 25T: 700 X
39	BLH5740	Bevel Gear-24T: 700 X	Blade 700 X: Kegellrad 24T	700 X - Pignon conique 24T	Ingranaggio conico 24T: 700 X
40	BLH5741	Tail Shaft Bevel Gear-24T: 700 X	Blade 700 X: Kegellrad Heckrotorwelle	700 X - Pignon conique d'axe d'anti-couple 24T	Ingranaggio conico albero coda: 700 X
41	BLH5742	Tail Shaft: 700 X	Blade 700 X: Heckrotorblattwelle	700 X - Axe d'anticouple	Albero coda: 700 X
42	BLH5743	Tail Pinion Shaft: 700 X	Blade 700 X: Welle f. Heckrotorrizel	700 X - Axe d'entraînement d'anti-couple	Pignone albero coda: 700 X
43	BLH5744	Boom Support Set: 700 X	Blade 700 X: Halter Heckausleger	700 X - Renforts de poutre de queue	Set supporto tubo coda: 700 X
44	BLH5745	Boom (2): 700 X	Blade 700 X: Heckausleger (2)	700 X - Poutre de queue (2)	Tubo coda: 700 X
45	BLH5746	Torque Tube Assembly: 700 X	Blade 700 X: Heckwelle	700 X - Arbre de transmission d'anticouple	Gruppo barra di torsione: 700 X
46	BLH5747	Torque Tube Holder: 700 X	Blade 700 X: Halter f. Heckwelle	700 X - Support d'arbre de transmission	Supporto barra di torsione: 700 X
47	BLH5748	Tail Pushrod Set (2): 700 X	Blade 700 X: Gestänge	700 X - Set de commande d'anticouple (2)	Set comandi coda: 700 X
48	BLH5749	Tail Pushrod Guide Set: 700 X	Blade 700 X: Gestängeführung Heck	700 X - Guides de commande d'anticouple	Set guida comandi coda: 700 X
49	BLH5750	Horizontal Fin Mount: 700 X	Blade 700 X: Halter f. Heckfinne	700 X - Support de stabilisateur	Supporto impennaggio orizzontale: 700 X

#	Part #	English	Deutsch	Français	Italiano
50	BLH5751	Fin Set: 700 X	Blade 700 X: Finnenset	700 X - Set d'empennages	Set impennaggio: 700 X
51	BLH5752	Tail Rotor Pitch Lever Set: 700 X	Blade 700 X: Heckrotorpitchhebelset	700 X - Levier de pas d'anticouple	Set leve passo rotore coda: 700 X
52	BLH5753	Tail Rotor Pitch Control Slider Set: 700 X	Blade 700 X: Schiebehülse Heckrotor Set	700 X - Coulisseau d'anticouple	Set cursore controllo passo coda: 700 X
53	BLH5754	Tail Pitch Slider Yolk: 700 X	Blade 700X : Heckkumlenkhebel	700 X - Fourchette de coulisseau	Centrale cursore passo coda: 700 X
54	BLH5755	Tail Rotor Hub: 700 X	Blade 700 X: Heckrotorzentralstück	700 X - Moyeu d'anticouple	Mozzo rotore coda: 700 X
55	BLH5756	Tail Rotor Blade Grip: 700 X	Blade 700 X: Heckrotorblatthalter	700 X - Pieds de pales d'anticouple	Porta pale rotore coda: 700 X
56	BLH5757	Tail Bellcrank Mount: 700 X	Blade 700 X: Halter Heckrotorwinkelhebel	700 X - Support de levier d'anticouple	Supporto squadretta coda: 700 X
57	BLH5758	Tail Case Set: 700 X	Blade 700 X: Heckrotorgehäuse	700 X - Boîtier d'anticouple	Set scatola coda: 700 X
58	BLH5759	Battery Tray: 700 X	Blade 700 X: Akkuträger	700 X - Platine de fixation de batterie	Supporto batteria: 700 X
59	BLH5760	Battery Tray Mounting Posts: 700 X	Blade 700 X: Stützen Akkuhalter	700 X - Supports de platine porte batterie	Appoggi montaggio supporto batteria: 700 X
60	BLH5761	Snap Battery Tray Locking Mount: 700 X	Blade 700 X: Akkuverschluss	700 X - Support de verrouillage de la batterie	Aggancio supporto batteria: 700 X
61	BLH5762	Pinion 12T: 700 X	Blade 700 X: Ritzel 12T	700 X - Pignon 12T	Pignone 12T: 700 X
62	BLH5763	Pinion 13T: 700 X	Blade 700 X: Ritzel 13T	700 X - Pignon 13T	Pignone 13T: 700 X
63	BLH5764	Pinion 14T: 700 X	Blade 700 X: Ritzel 14T	700 X - Pignon 14T	Pignone 14T: 700 X
64	BLH5765	Pinion 15T: 700 X	Blade 700 X: Ritzel 15T	700 X - Pignon 15T	Pignone 15T: 700 X
65	BLH5766	8x16x5mm Radial Bearing	Blade 700 X: 8x16x5mm Radiallager	Roulement 8x16x5mm	8x16x5mm Cuscinetto radiale
66	BLH5767	12x24x6mm Radial Bearing	Blade 700 X: 12x24x6mm Radiallager	Roulement 12x24x6mm	12x24x6mm Cuscinetto radiale
67	BLH5768	8x16x5mm Thrust Bearing	Blade 700 X: 8x16x5mm Drucklager	Butée à billes 8x16x5mm	8x16x5mm Cuscinetto radiale
68	BLH5769	5x10x4mm Thrust Bearing	Blade 700 X: 5x10x4mm Drucklager	Butée à billes 5x10x4mm	5x10x4mm Cuscinetto radiale
69	BLH5561	12x18x4mm Radial Bearing	Blade 700 X: 12x18x4mm Radiallager	Roulement 12x18x4mm	12x18x4mm Cuscinetto radiale
70	BLH1642	5x10x4mm Radial Bearing	Blade 700 X: 5x10x4mm Radiallager	Roulement 5x10x4mm	5x10x4mm Cuscinetto radiale
71	BLH5770	Hook and Loop Battery Strap: 700 X	Blade 700 X: Klettschlaufe	700 X - Sangle auto-agrippante	Fascetta a strappo per batteria: 700X
72	RV0T011500	115mm Carbon Fiber 3D Tail Rotor Blades	Revolution 115mm Carbon Fiber 3D Heckrotorblätter	Pales d'anticouple 3D en carbone 115mm	115mm Pale coda in carbonio per 3D
73	RV0B069050	690mm FBL 3D Carbon Main Blades	Revolution 690mm FBL 3D Carbon Hauptrotorblatt	Pales principales FBL 3D en carbone 690mm	690mm Pale principali in carbonio per 3D e FBL
	BLH5771	Helicopter Main Blade Holder: 700 X	Blade 700 X: Blatthalter	700 X - Support des pales principales	Supporto pala principale heli: 700 X
74	BLH5772	Hardware Set: 700 X	Blade 700 X: Kleinteile	700 X - Set de visserie	Set viteria: 700 X
75	BLH5773	Gear Pins	Blade Ritzelsplint	Goupilles d'entraînement de pignons	Perni ingranaggio
76	BLH5774	Rubber Frame Inserts	Blade Gummieinsätze	Inserts de châssis en caoutchouc	Inserti telaio in gomma
77	EFLM60700B	Heli 700 Brushless Outrunner Motor, 520Kv	E-flite Heli 700 Brushless Aussenläufer Motor, 520Kv	Moteur brushless 700 Héli à cage tournante 520kv	Heli 700 motore a cassa rotante brushless 520Kv
78	EFLA2100	100-Amp HV Brushless ESC	E-flite 100-Amp HV Brushless ESC / Regler	Contrôleur brushless 100A HV	100-Amp Regolatore (ESC) brushless
	EFLA108	HV Speed Control Programmer	HV Speed Control Programmierkarte	Programmeur de contrôleur HV	HV Programmatore x regolatore velocità

Optional Parts / Optionale Bauteile / Pièces optionnelles / Pezzi opzionali

Part #	English	Deutsch	Français	Italiano
BLH5730B	Black Landing Gear: 700 X	Blade 700 X: Kufengestell schwarz	700 X - Train d'atterrissage noir	Carrello atterraggio nero: 700 X
BLH5718S	One-Way Bearing Hub w/Sprague bearing: 700 X	Blade 700 X: Freilauf	700 X - Moyeu de roue libre avec roue libre à cames	Mozzo cuscinetto unidirezionale con ruota libera: 700 X
BLH5775	3-Blade Head Conversion: 700 X	Blade 700X : 3-Blatt Rotorkopfbau	700 x - Conversion tripale	Conversione testa a 3 pale: 700 X
BLH5776	3-Blade Head Spindle (3): 700 X	Blade 700X : 3-Blattlagerwelle	700 X - Axes de pieds de pales pour conversion tripale (3)	Alberino testa 3 pale: 700 X
BLH5777	3-Blade Head Block: 700 X	Blade 700X : 3 Blattrotorkopf	700 X - Moyeu de tête pour conversion tripale	Bloccaggio testa 3 pale: 700 X
BLH5735A	Metal FBL Unit Mount: 700 X"	Blade 700X : Metallhalter FBL Einheit	700 X - Support en métal de module de contrôle FBL	Supporto metallo per unità FBL: 700 X"
BLH5732A	Metal Anti-Rotation Bracket: 700 X	Blade 700X : Metall Taumelscheibeführung	700 X - Guide anti-rotation en métal	Staffa in metallo anti rotazione: 700 X
BLH5778	Metal Tail Servo Bracket: 700X	Blade 700X : Metall Heckservohalter	700 X - Support de servo d'anticouple en métal	Staffa in metallo servo coda: 700X
BLH5752A	Metal Tail Rotor Pitch Lever Set: 700 X	Blade 700 X: Metall Heckrotorpitchhebelset	700 X - Levier d'anticouple en métal	Set leve in metallo per passo rotore: 700 X
RV0B071050	710mm FBL 3D Carbon Main Blades	Revolution 710mm FBL 3D Carbon Hauptrotorblatt	Pales principales FBL 3D en carbone 710mm	710mm Pale principali in carbonio per 3D e FBL
SPMSH6200	H6200 HV Digital High Speed Heli Cyclic MG Servo	Spektrum H6200 HV Digital Hi Speed Heli Taumelscheibenservo MG	Servo H6200 HV digital, haute vitesse, pignons métal pour le cyclique	H6200 HV Servo digitale MG, alta velocità per ciclico heli
SPMSH6210	H6210 HV Digital Ultra Speed Heli Tail MG Servo	Spektrum H6210 HV Digital Ultra Speed Heli Heckservo MG	Servo H6210 HV digital, haute vitesse, pignons métal, pour l'anticouple	H6210 Servo digitale MG, super alta velocità per coda heli

©2013 Horizon Hobby, Inc.

Blade, E-flite, Dynamite, Revolution, EC5, Celectra, DSM, DSM2, DSMX, AirWare, ModelMatch and the Horizon Hobby logo are trademarks or registered trademarks of Horizon Hobby, Inc.

The Spektrum trademark is used with permission of Bachmann Industries, Inc.

BeastX is a registered trademark of Markus Schaack and is used with permission.

The Spektrum AR7200BX employs technology exclusively licensed to Horizon Hobby, Inc. from freakware GmbH.

Created 5/13 39874