

Name: _____		Date: _____		Event: _____	
City: _____		State: _____		Track: _____	
Track Conditions	<input type="checkbox"/> Indoor	<input type="checkbox"/> Tight	<input type="checkbox"/> Smooth	<input type="checkbox"/> Hard Packed	<input type="checkbox"/> Blue Groove
	<input type="checkbox"/> Outdoor	<input type="checkbox"/> Open	<input type="checkbox"/> Rough	<input type="checkbox"/> Loose/Loamy	<input type="checkbox"/> Dry
				<input type="checkbox"/> Wet	<input type="checkbox"/> Dusty
				<input type="checkbox"/> Grass	<input type="checkbox"/> Astro Turf
				<input type="checkbox"/> Low Bite	<input type="checkbox"/> Med Bite
				<input type="checkbox"/> High Bite	<input type="checkbox"/> Other _____

### Front Suspension

Toe: \_\_\_\_\_

Ride Height: \_\_\_\_\_ Camber: \_\_\_\_\_

Caster:  0°  5°

Kick Angle:  20°  25°  30°

VLA Setting:  Short Arm  Long Arm

Oil: \_\_\_\_\_

Piston: \_\_\_\_\_

Spring:  Standard  Low Freq. Color: \_\_\_\_\_

Front Pivot:  Aluminum  Plastic  HRC

Kick Shim:  Brass  Plastic

Shock Limiters: \_\_\_\_\_ Stroke: \_\_\_\_\_

Shock Location: \_\_\_\_\_

Steering Type:  Slide Rack  Bell Cranks

Spindle Ball Stud:  Standard  Low Mount

Bumper Steer Spacers: \_\_\_\_\_

Ackerman Ball Stud:  Standard  Low Mount

Ackerman Spacers: \_\_\_\_\_

Ackerman Arm:  #1  #2  #3  \_\_\_\_\_

Trail:  2mm  3mm  4mm

Camber Link: \_\_\_\_\_

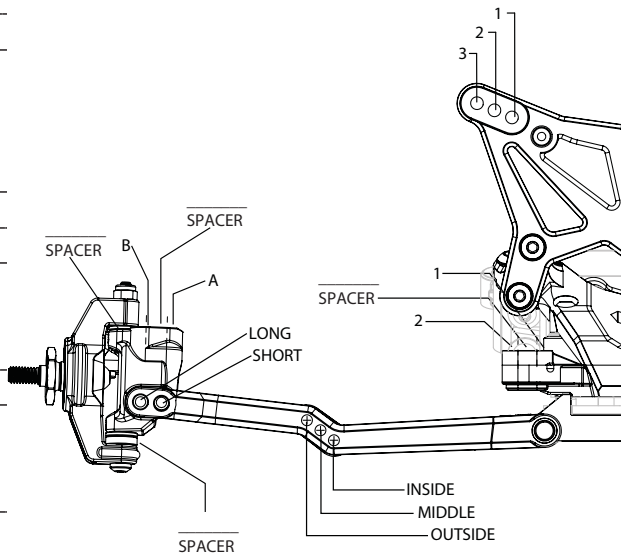

Notes: \_\_\_\_\_

\_\_\_\_\_

\_\_\_\_\_

### Rear Suspension

Transmission Type:  3-Gear  4-Gear

Toe Inserts:  0.5°  1°  1.5°  2°  2.5°  3°  3.5°  4°

Anti-Squat Inserts:  0°  0.5°  1°  1.5°  2°  2.5°  3°

Roll Center:  Low Roll Center (LRC)  High Roll Center (HRC)

Ride Height: \_\_\_\_\_ Camber: \_\_\_\_\_

Rear Hub Spacing: \_\_\_\_\_

Hex Width: \_\_\_\_\_

Sway Bar: \_\_\_\_\_

Oil: \_\_\_\_\_

Piston: \_\_\_\_\_

Spring:  Standard  Low Freq. Color: \_\_\_\_\_

Shock Limiters: \_\_\_\_\_ Stroke: \_\_\_\_\_

Shock Location: \_\_\_\_\_

Inner Link Spacer:  -1mm  0mm  +1mm

Camber Link: \_\_\_\_\_

Body: \_\_\_\_\_

Battery Position: \_\_\_\_\_

Diff Type:  Ball  Gear Setting: \_\_\_\_\_

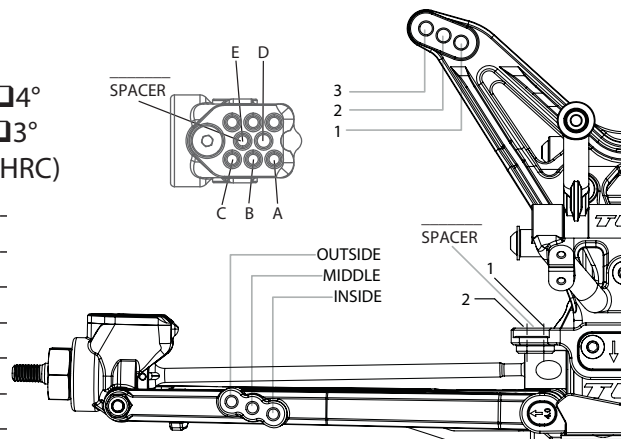

### Electronics

Radio: \_\_\_\_\_

Servo: \_\_\_\_\_

ESC: \_\_\_\_\_

Initial Brake: \_\_\_\_\_

Drag Brake: \_\_\_\_\_

Throttle Profile: \_\_\_\_\_

Timing Advance: \_\_\_\_\_

Throttle/Brake Expo: \_\_\_\_\_

Servo Expo: \_\_\_\_\_

Throttle/Brake EPA: \_\_\_\_\_

Motor: \_\_\_\_\_

Pinion: \_\_\_\_\_ Spur: \_\_\_\_\_

Battery: \_\_\_\_\_

Weight Placement  
(Mark with "X")

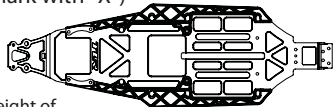

Weight of each piece \_\_\_\_\_ oz./g

Tires:	Compound	Insert	Additive
Front: _____	_____	_____	_____
Rear: _____	_____	_____	_____
Notes: _____	_____	_____	_____