



RIVAL MT8

**1:8 Scale Ready-To-Run 4WD
Electric Off Road Monster Truck**

#20520 RIVAL MT8 Ready-To-Run

SCALE **1:8** VEHICLE

RTR READY TO RUN

4 WHEEL DRIVE

ELEC. POWERED

OFF ROAD

2.4GHz

PRE-PAINTED

INCLUDES **LED** FOUR PIECE LIGHT SET

BRUSHLESS POWERED
READY-TO-RUN

1:8 Scale Ready-To-Run 4WD Electric Off Road Monster Truck Manual



CHAMPIONS by DESIGN

AssociatedElectrics.com



:: Introduction

Thank you for purchasing this Team Associated product. This assembly manual contains instructions and tips for building and maintaining your new vehicle. Please take a moment to read through the manual and familiarize yourself with the steps. We are continually changing and improving our designs; therefore, actual parts may appear slightly different than the illustrations. New parts will be noted on supplementary sheets located in the appropriate parts bags. Check each bag for these sheets before you start to build.

:: Rival MT8 RTR Features

- 4mm thick aluminum main chassis
- 22 precision ball bearings
- Heavy duty hardened steel CVA axles
- 16mm Big Bore threaded aluminum shock bodies
- Sealed drivetrain
- Three heavy-duty sealed silicone filled gear differentials
- Rigid aluminum center chassis supports
- Aluminum suspension braces
- Four position adjustable wheelie bar
- All metal gear drivetrain
- Rugged steel turnbuckles
- High torque digital servo
- Metal servo horn
- Single 6S or 4S ready 150A ESC
- 2100kv high torque brushless motor

:: Table of Contents

1..... Cover	6 - 19.....Steps 1- 41
2..... Introduction	21.....Tuning Tips
3.....1:1 Hardware "Fold Out"	22.....Back Cover
4 - 5..... Quick Start Guide	

:: Notes



There is a 1:1 hardware foldout page in the front of the manual. To check the size of a part, line up your hardware with the correct drawing until you find the exact size. Each part in the foldout has a number assigned to it for ordering replacement parts.



This symbol indicates a special note or instruction in the manual.

:: Additional

Your new Rival MT8 comes assembled. The following items are needed for completion.

- 4S or 6S LiPo battery
- Suitable battery charger
- (4) AA batteries

Tools included: • 1.5mm, 2.0mm, 2.5mm Wrenches

:: Other Helpful Items

- Silicone Shock Fluid (Refer to catalog for complete listings)
- Silicone Diff Fluid (Refer to catalog for complete listings)
- Body Scissors (AE Part # 1737)
- Reamer / Hole Punch (#1499)
- Shock Pliers (#1675)
- Wire Cutters
- FT Hex/Nut Wrenches (AE Part # 1650)
- 17mm Wheel Wrench (#1571)
- Needle Nose Pliers
- Hobby Knife
- Calipers or a Precision Ruler
- Green Slime shock lube (AE Part # 1105)
- Soldering Iron
- FT Turnbuckle Wrench (#1114)
- FT Universal Tire Balancer (#1498)

















Associated Electrics, Inc.
21062 Bake Pkwy.
Lake Forest, CA 92630













Customer Service
Tel: 949.544.7500
Fax: 949.544.7501

:: Hardware - 1:1 Scale View



Button Head (bhcs)

	2.5x6mm (31520)
	3x5mm (31530)
	3x8mm (31532)
	3x10mm (25211)
	3x12mm (89202)
	3x14mm (25187)
	3x16mm (89203)
	3x18mm (2308)
	3x20mm (25188)
	3x26mm (89205)
	4x8mm (81265)
	4x10mm (89206)
	4x12mm (89207)
	4x14mm (81260)
	4x16mm (81261)
	4x20mm (81266)

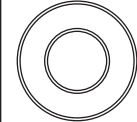
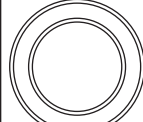

Flat Head (fhcs)

	2.5x8mm (31448)
	3x6mm (31541)
	3x8mm (25201)
	3x10mm (25202)
	3x12mm (25203)
	3x25mm (89243)
	4x10mm (81262)
	4x12mm (89214)
	4x14mm (89217)
	4x16mm (81263)





Ball Bearings

	5x8x2.5mm (8680)
	8x16x5 (91564)
	12x18x4 (25843)
	10x19x5mm (25940)

Set Screws

	3x3mm (25225)
	4x3mm (25223)
	4x20mm (89245)

Nuts (lock/plain)

	Plain M3 Nut (91477)
	M3 Alum. Locknut, Blue (31550)
	M3 Locknut, Black (25215)
	M5 Locknut w/Flange (25837)

Socket Head (shcs)

	3x35mm (25653)
	5x85mm (25946)

Notes:

:: Quick Start Guide

Battery Charging Steps and Safety:

Remove the battery from the vehicle before charging.
Place battery on a fire resistant surface.
Avoid any contact with water or other liquids.
Be sure to select the correct charging mode for the type of battery you are charging.

ALWAYS use a compatible charger for charging your batteries.

Caution: Never leave the battery unattended while charging. Always disconnect the charger from the power source when finished charging.

Caution: Always disconnect the battery when you are finished driving the vehicle.



**Peak Detection
Quick Charger**

:: Quick Start Guide - (cont.)

Battery Installation:

1. Install the battery with the battery wires directed towards the rear of the vehicle.
2. Secure the battery strap using two hook and loop straps.

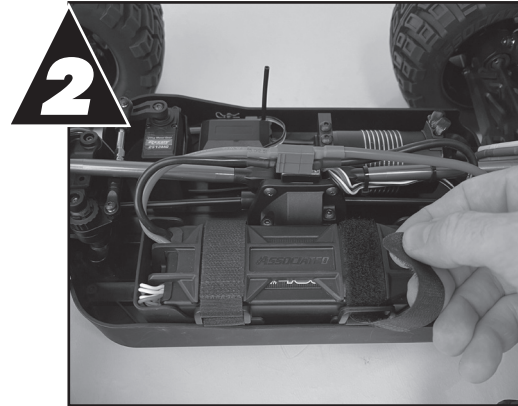

:: Quick Start Guide - (cont.)

Battery Notes and Tip:

Connect the battery as shown.
Disconnect the battery when not in use!

LiPo: LiPo batteries (lithium polymer) are high current rechargeable batteries. LiPo batteries offer extended run time and peak performance over NiMH batteries. They require a peak detection charger designed specifically for LiPo batteries. These batteries require special care and handling. LiPo batteries are recommended for advanced users only!
ALWAYS charge a LiPo battery in LiPo mode.

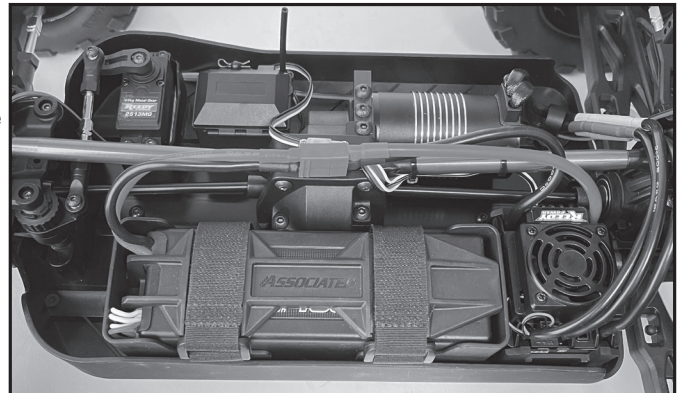

:: Quick Start Guide - (cont.)

Radio System Tuning and Controls:

RULE: Transmitter on First/Vehicle on Second,
Vehicle off First/ Transmitter off Last!

- 1) Slide the battery cover to remove cover.
- 2) Install alkaline or rechargeable AA size batteries into the battery holder.
- 3) Slide the battery cover back into place making sure it is completely closed and secure.
- 4) Turn the power ON. If the power indicator LED fails to light, check the batteries for insufficient contact or incorrect polarity.



On/Off Switch

:: Quick Start Guide - (cont.)

Radio System Tuning and Controls:

DO NOT hold the trigger when turning on the radio.

Refer to Radio owners manual for more in-depth instructions on radio operation and functions.

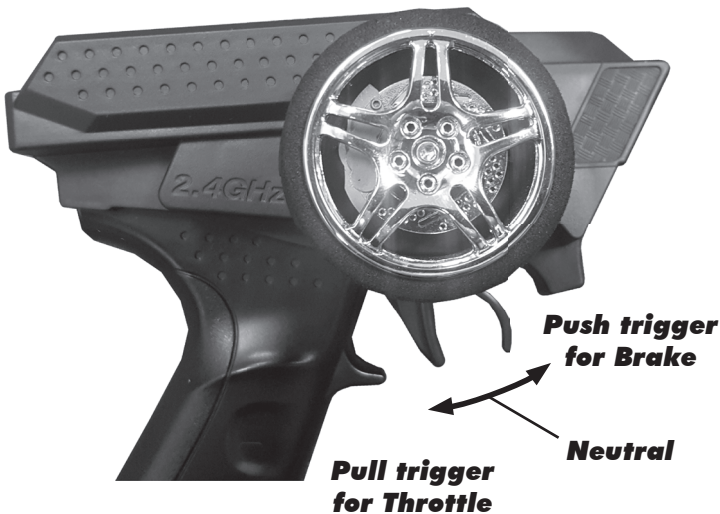

Throttle set to Neutral!



Adjust steering trim so front wheels point straight.

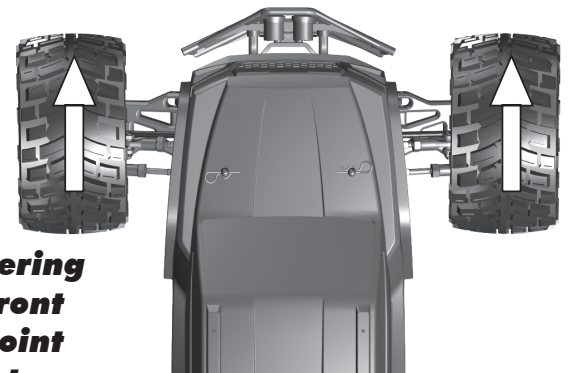

Install body and body clips. Ready to go!

:: Step 1

25926 X2
Sun Gear Shim

25926
Diff O-Ring

25923
Diff Case

25926
Bearing 10x19x5

25926
Outdrive

25926 X2
Sun Gear Shim

25926
Diff O-Ring

25924
Ring Gear, 38T

25926
Outdrive Shim

25926
Bearing 10x19x5

25926
Outdrive

25926
Sun Gear

25926
Input Pin

25926
Sun Gear

25926
Input Pin

Build 2 (1 front, 1 rear)

:: Step 2

25926 X4
Planetary Gear Shim

25926 X4
Planetary Gear

25926 X2
Diff Cross Pin

25926 X4
Cross Pin Insert

25203 X4
3x12mm FHCS

25926
Diff Gasket

diff fluid

Front Diff Fluid:
60k cst #5458

Rear Diff Fluid:
30k cst #5457

:: Step 3

25926 X2
Sun Gear Shim

25926
Diff O-Ring

25926
Bearing 10x19x5

25926
Outdrive

25925
O-Ring

25923
Diff Case

25926
Sun Gear Shim

25926
Diff O-Ring

25926
Bearing 10x19x5

25926
Outdrive

25925
O-Ring

25904
Spur Gear, 48T

25926
Sun Gear

25926
Input Pin

25926
Sun Gear

25926
Input Pin

Build 1 (1 center)

:: Step 4

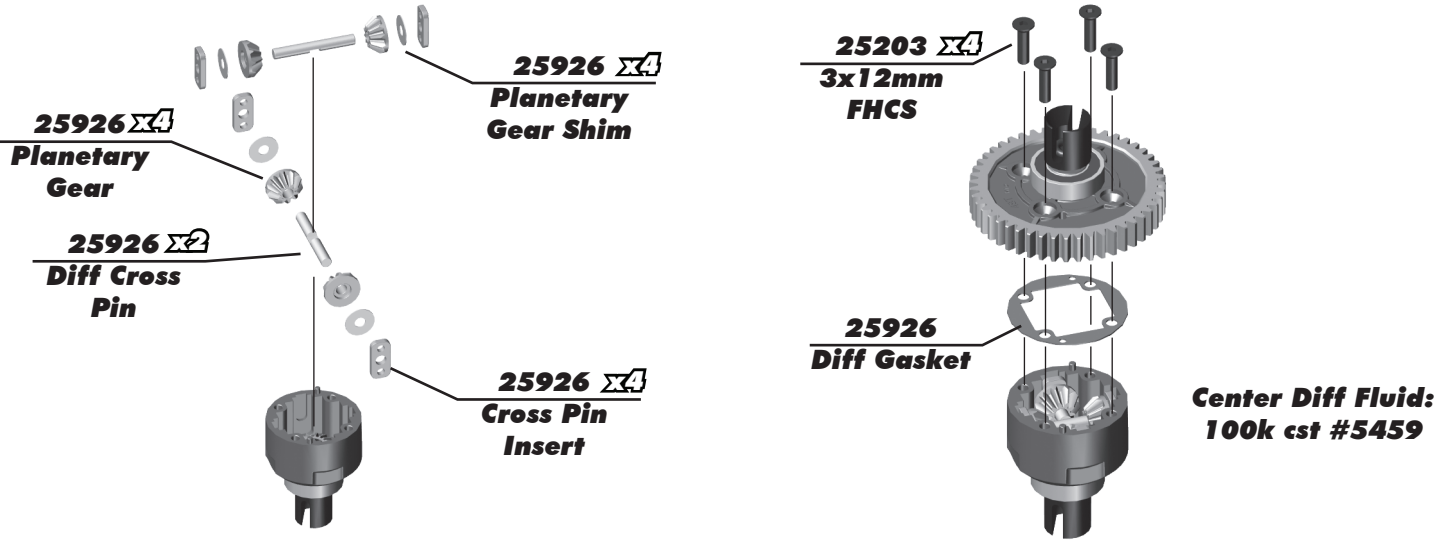

:: Step 5

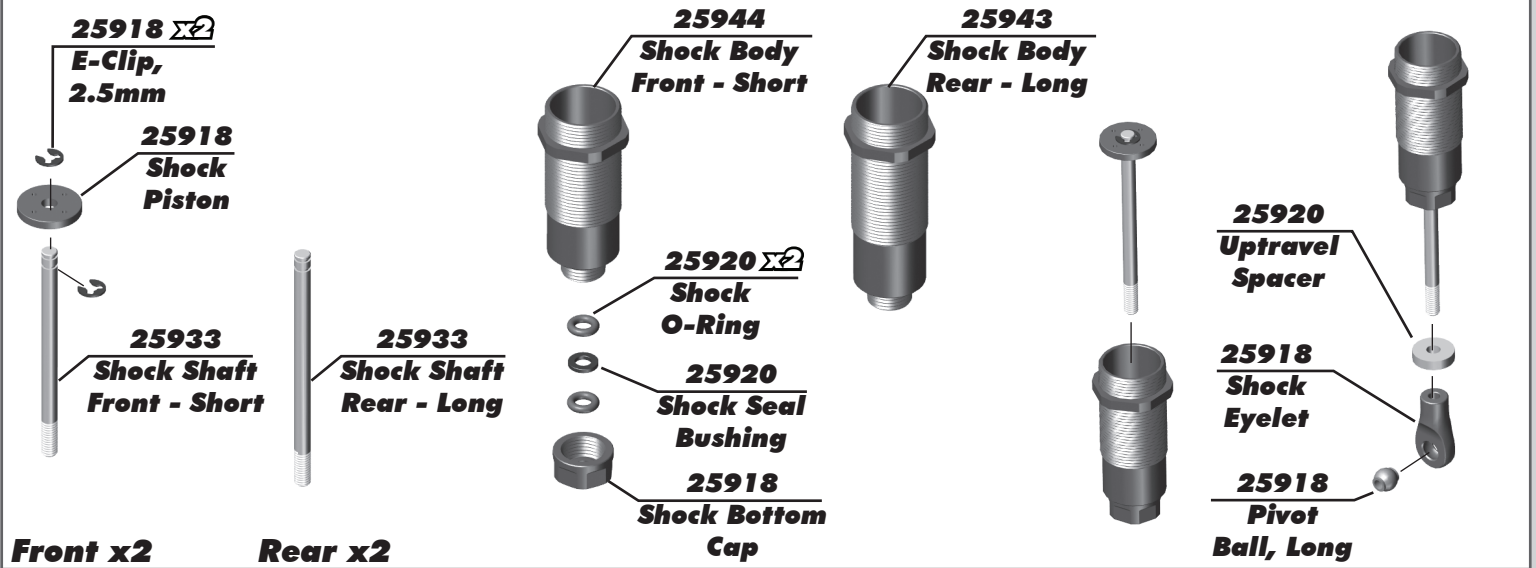

:: Step 6

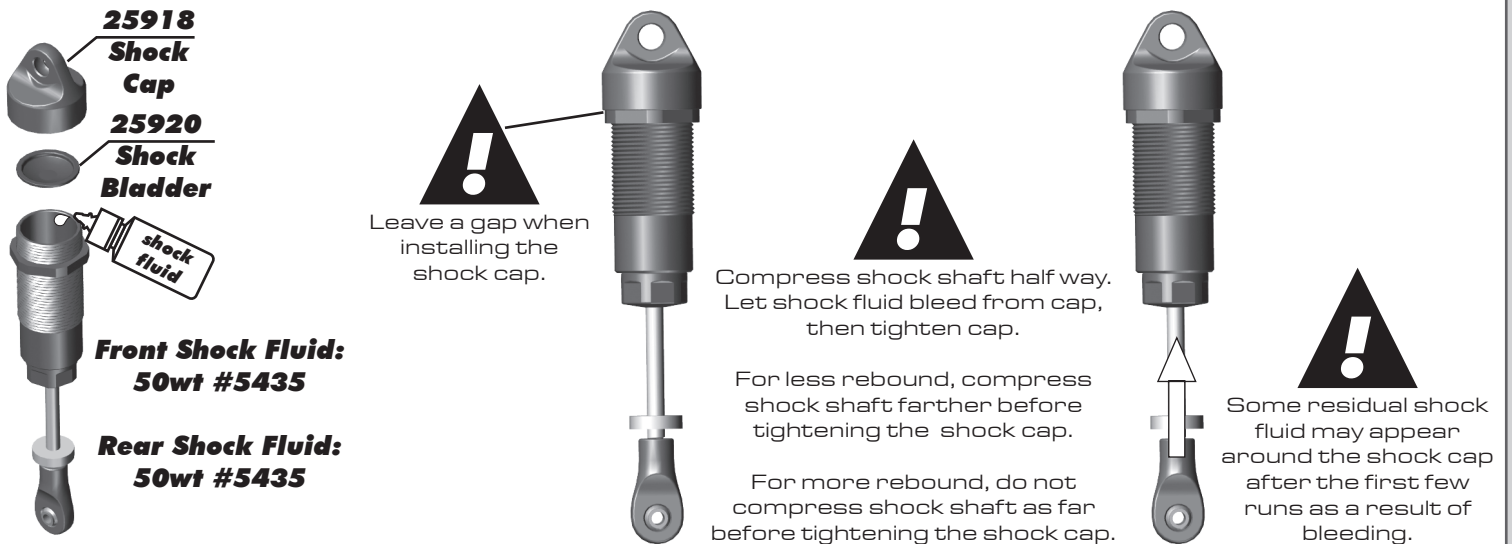

:: Step 7

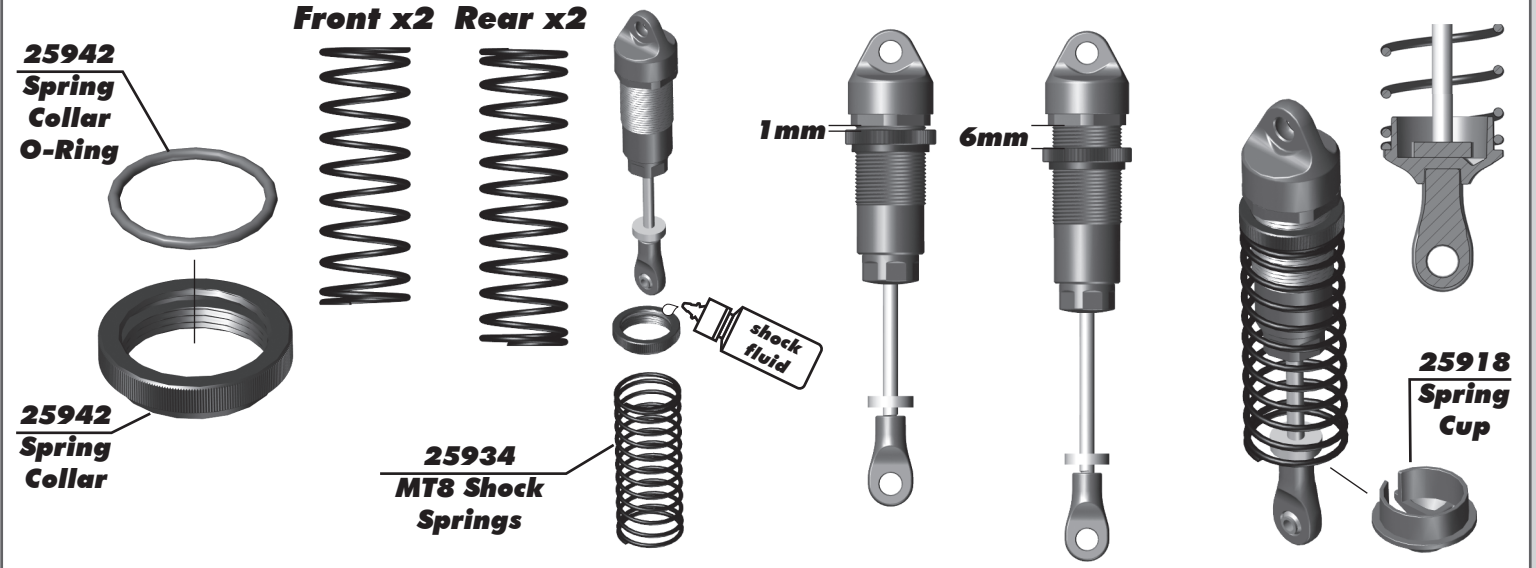

:: Step 8

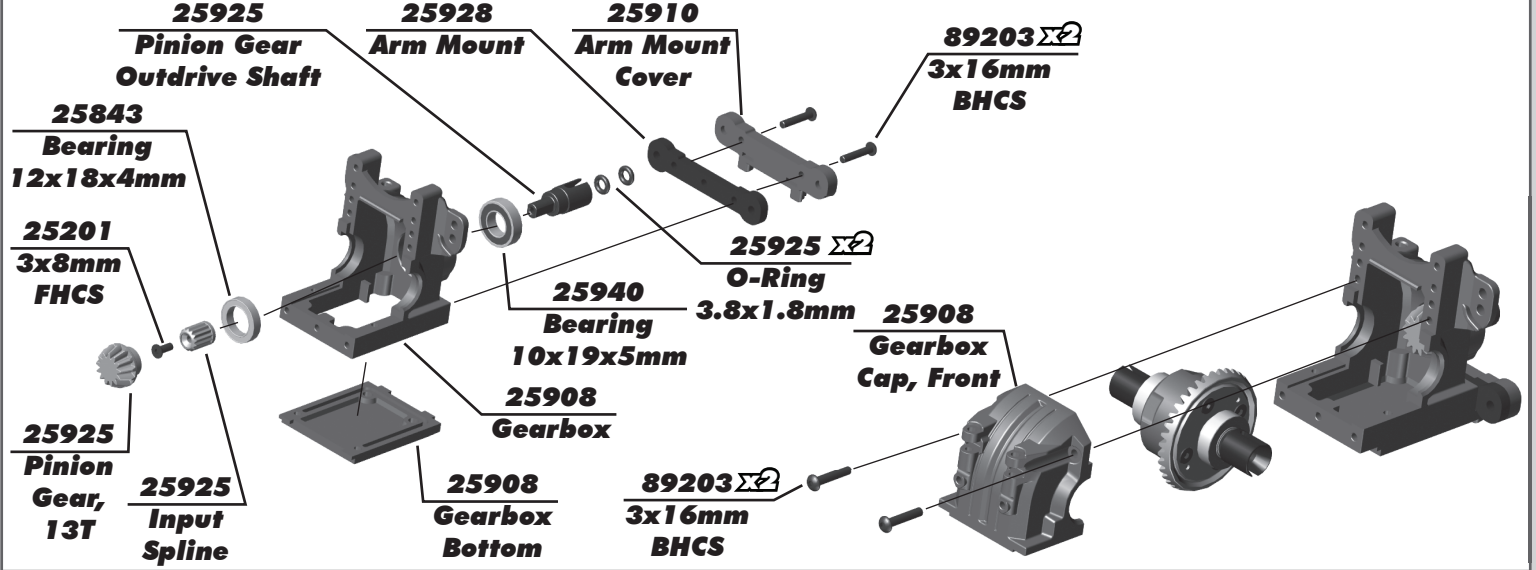

:: Step 9

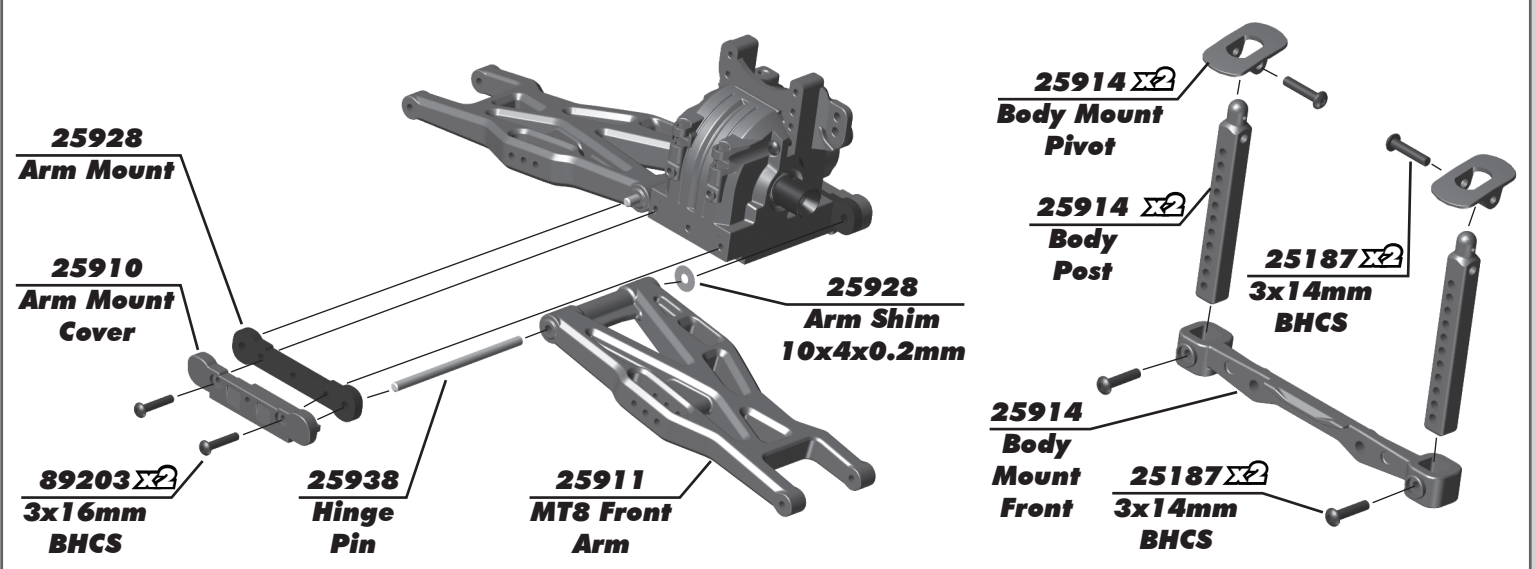

:: Step 10

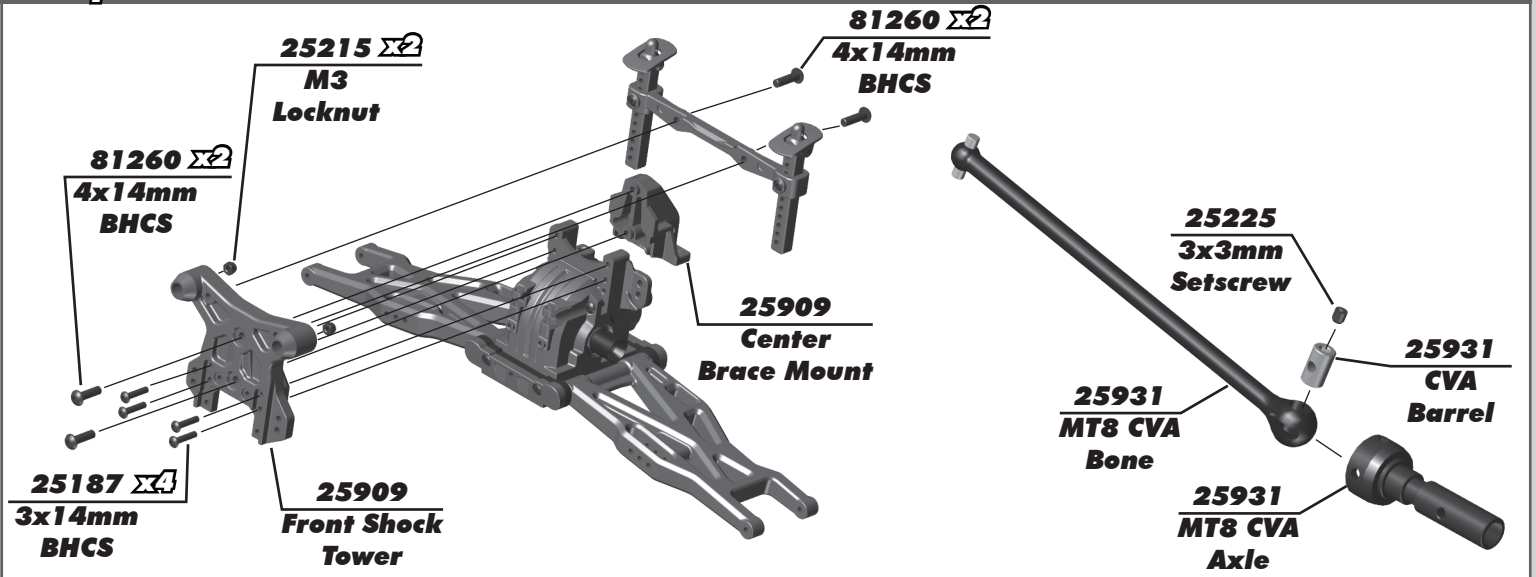

:: Step 11

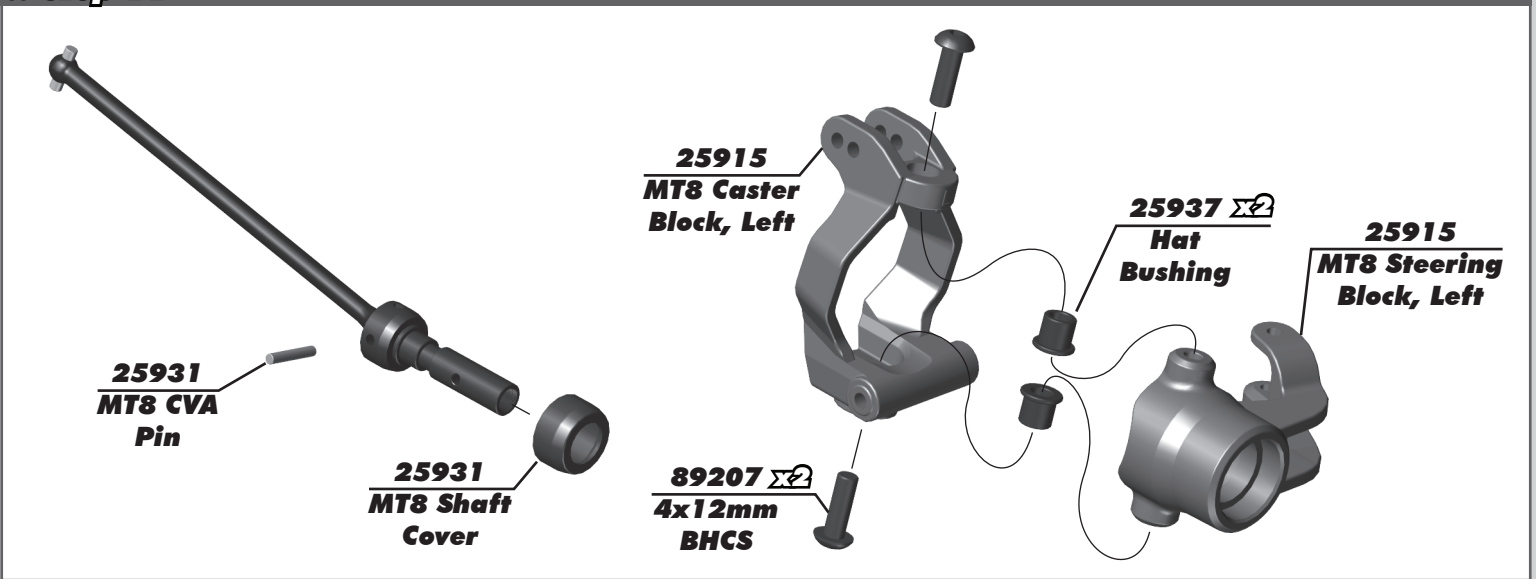

:: Step 12

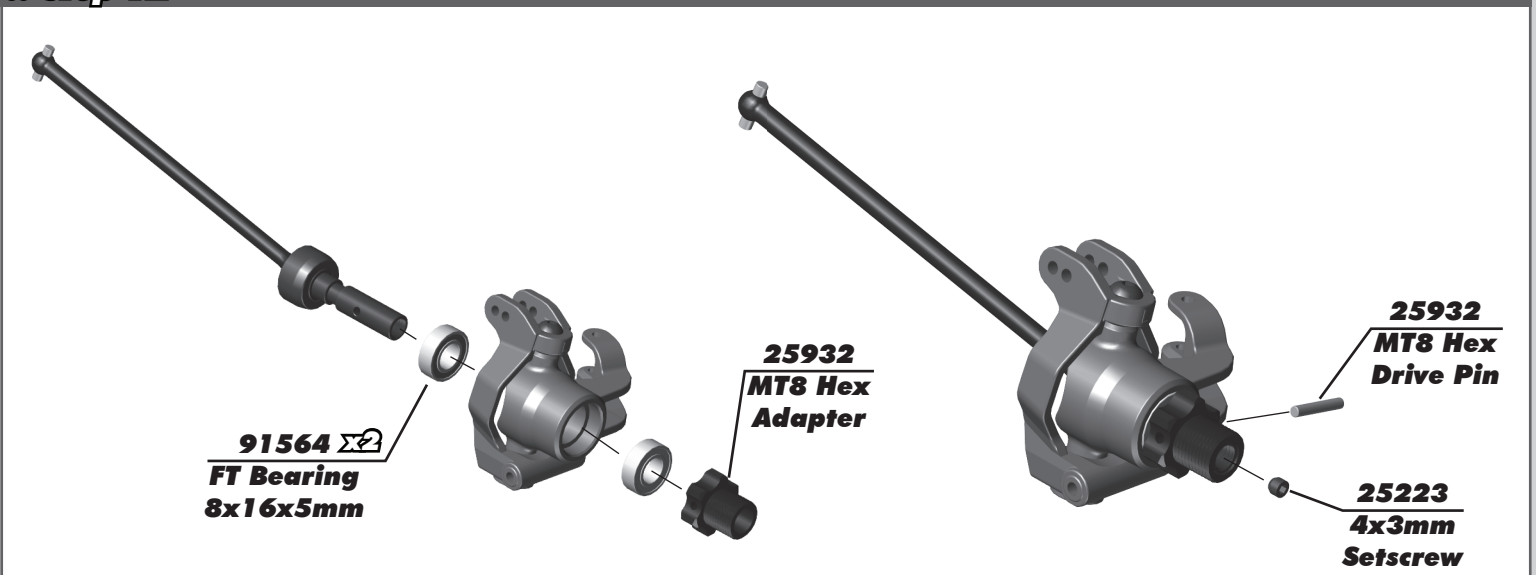

:: Step 13

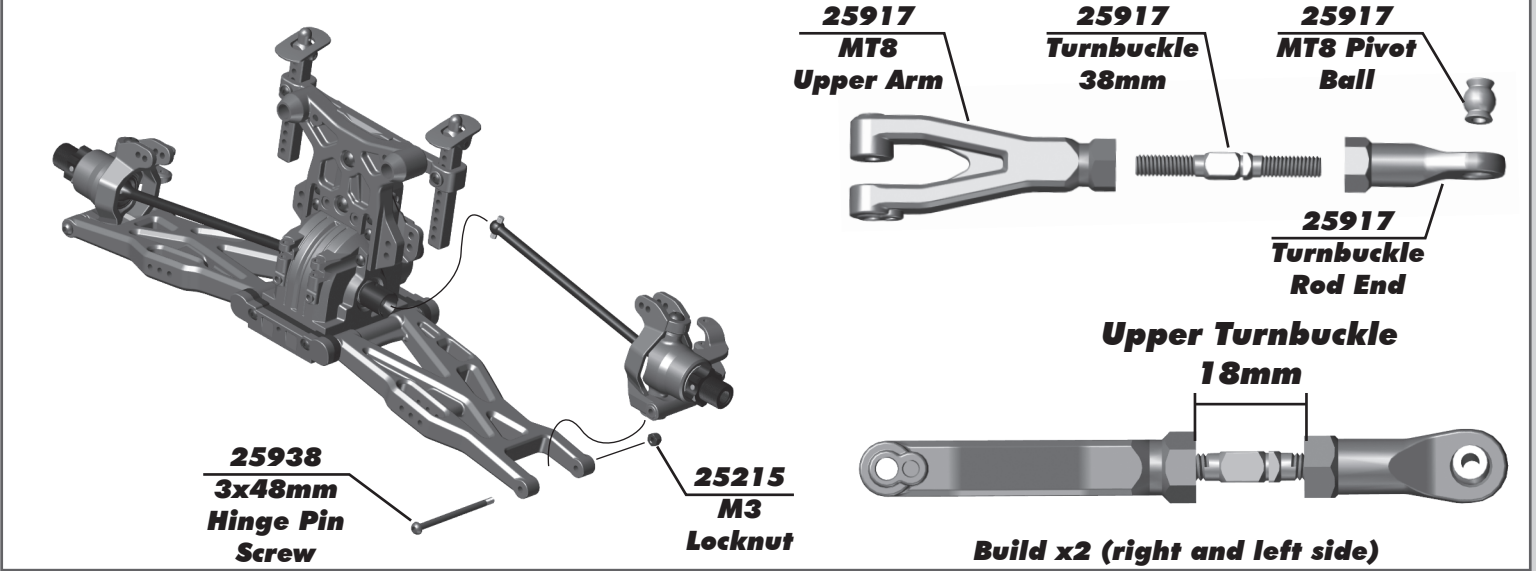

:: Step 14

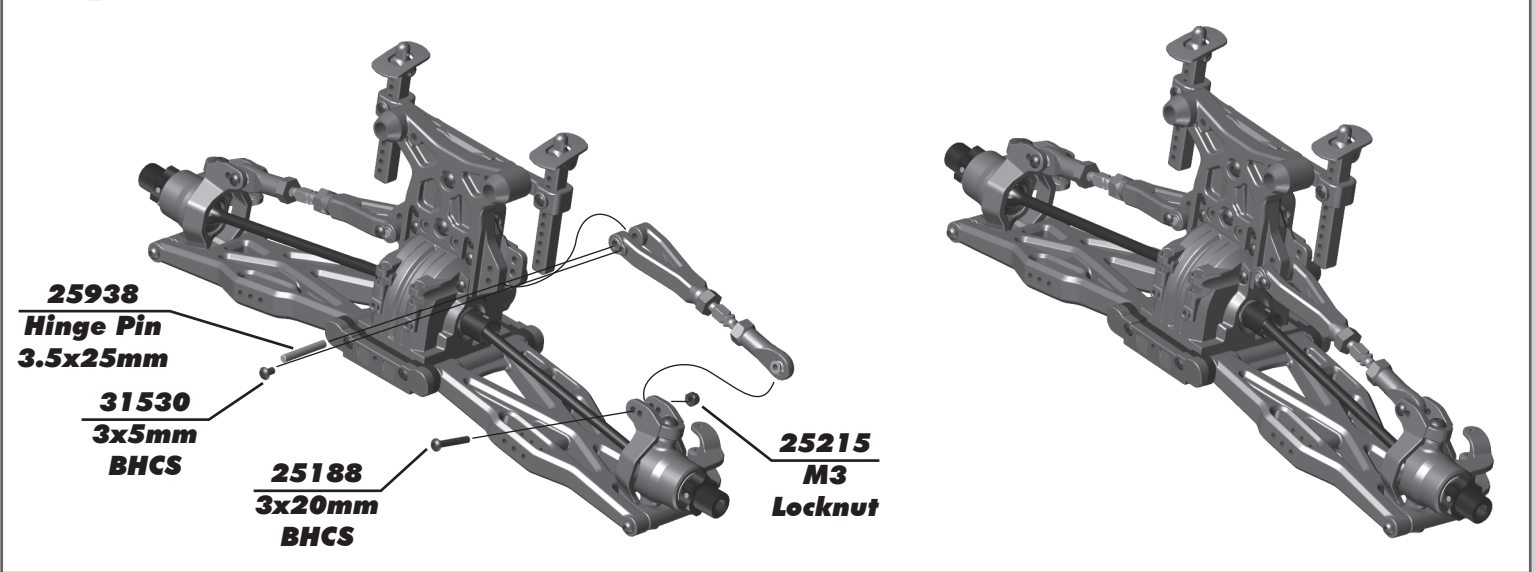

:: Step 15

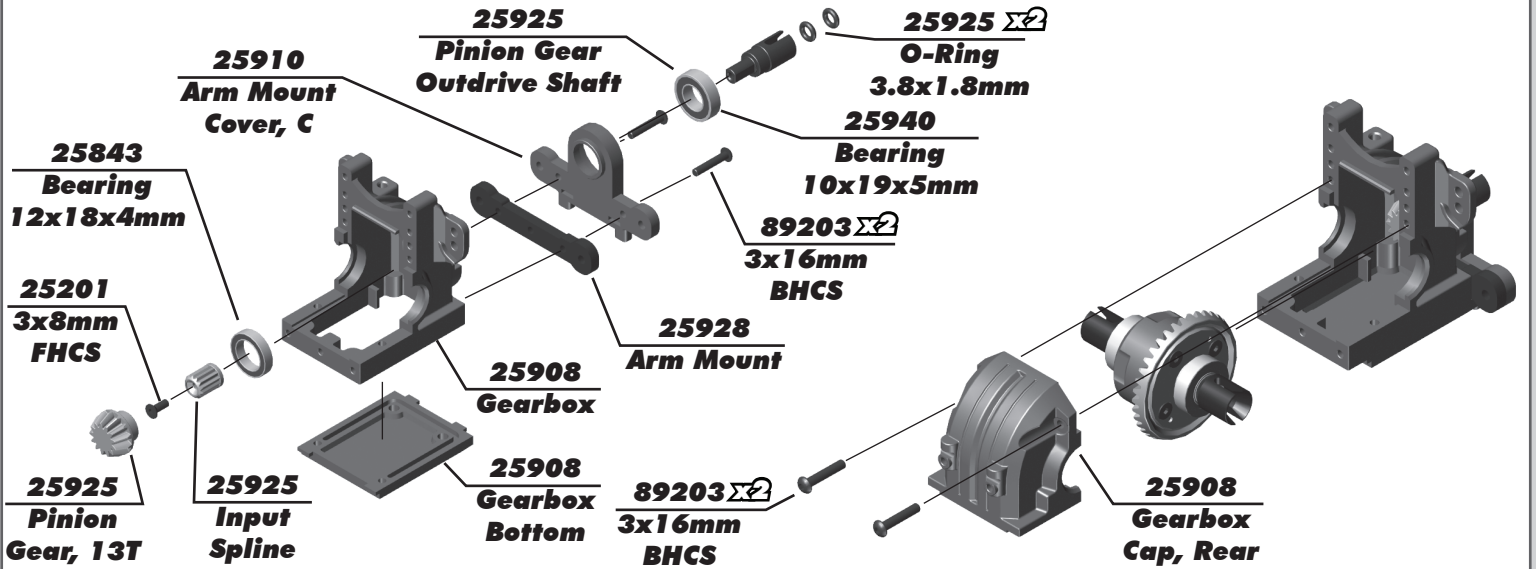

:: Step 16

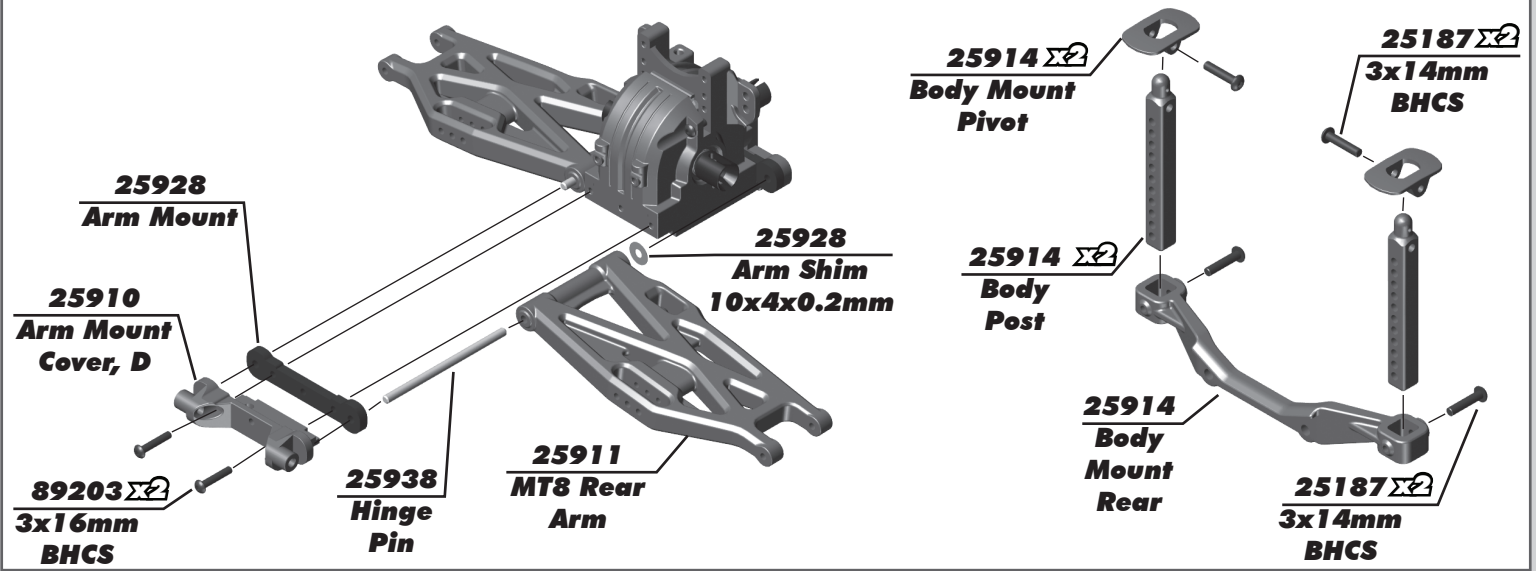

:: Step 17

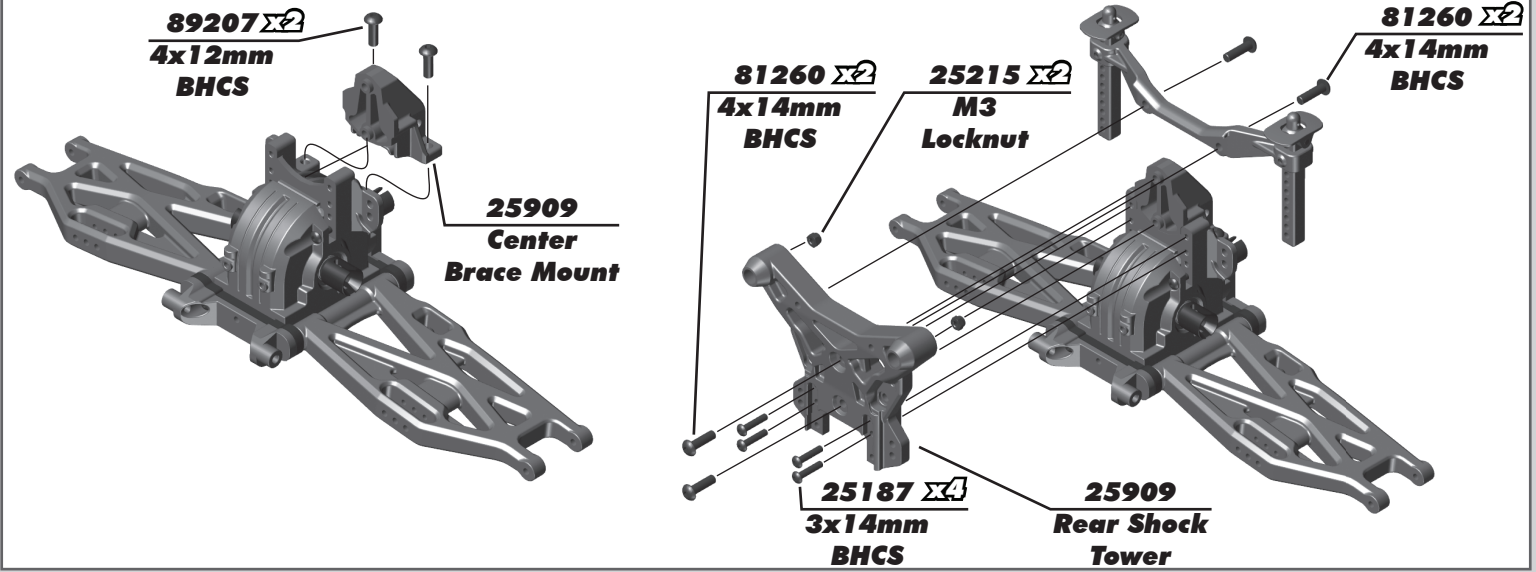

:: Step 18

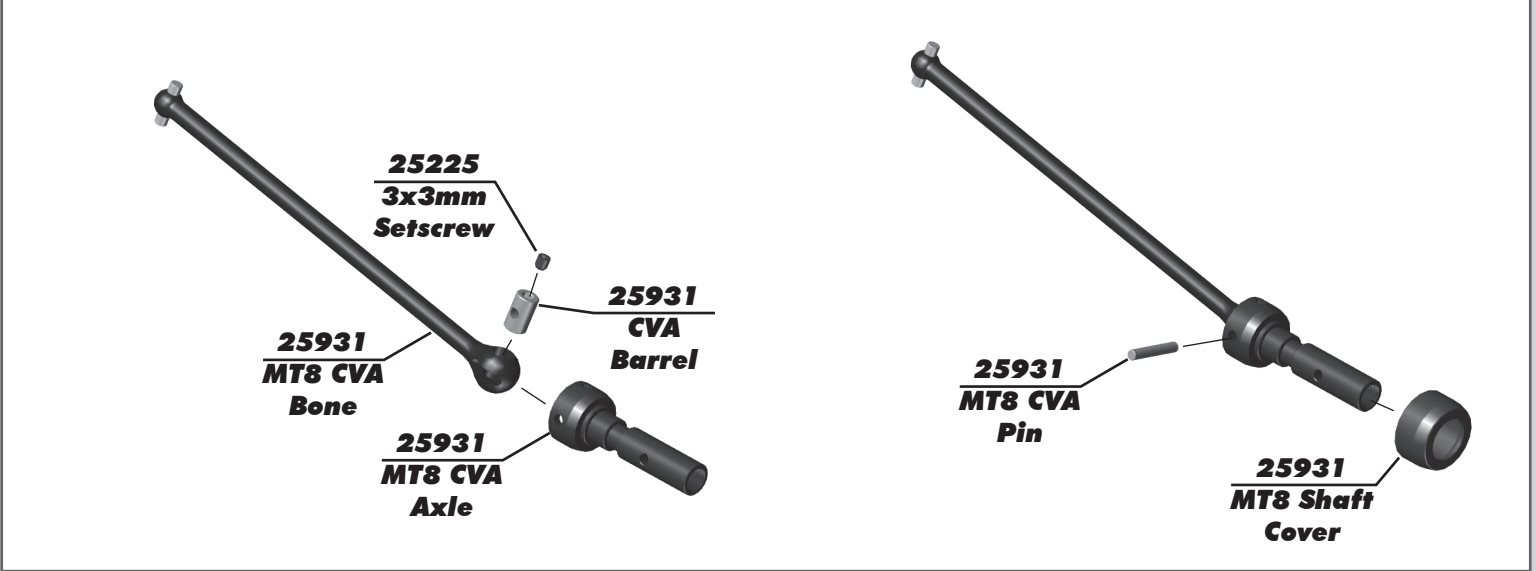

:: Step 19

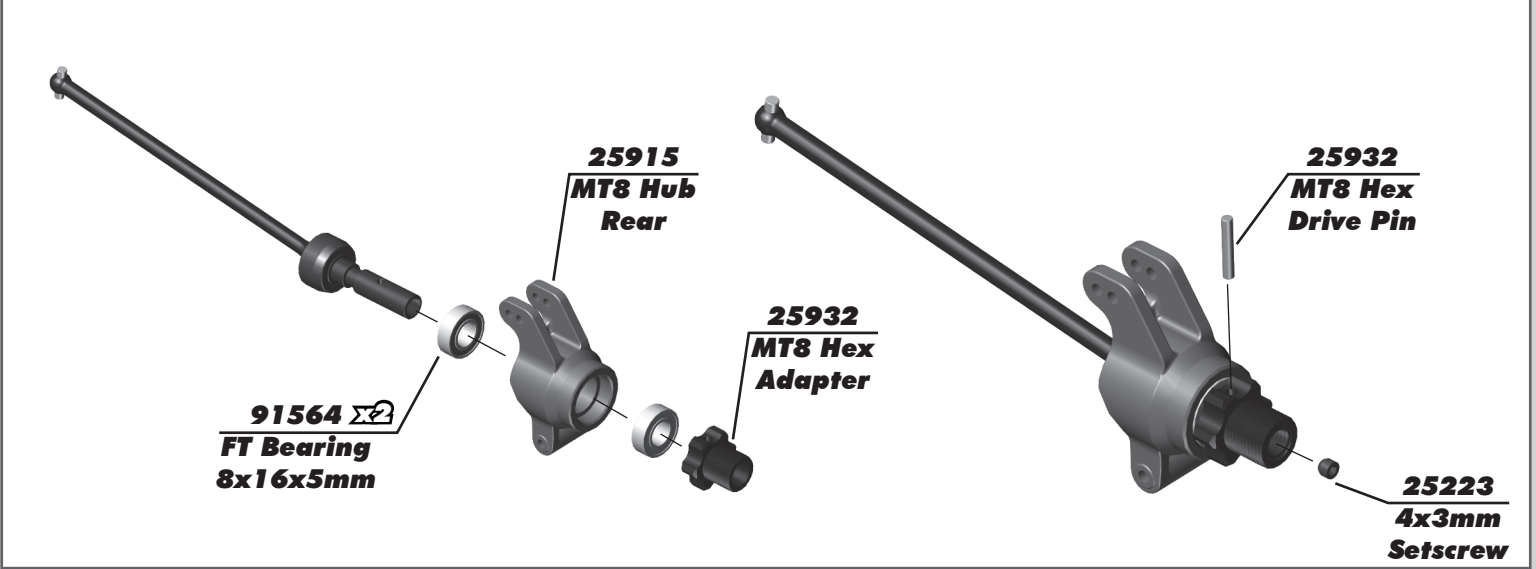

:: Step 20

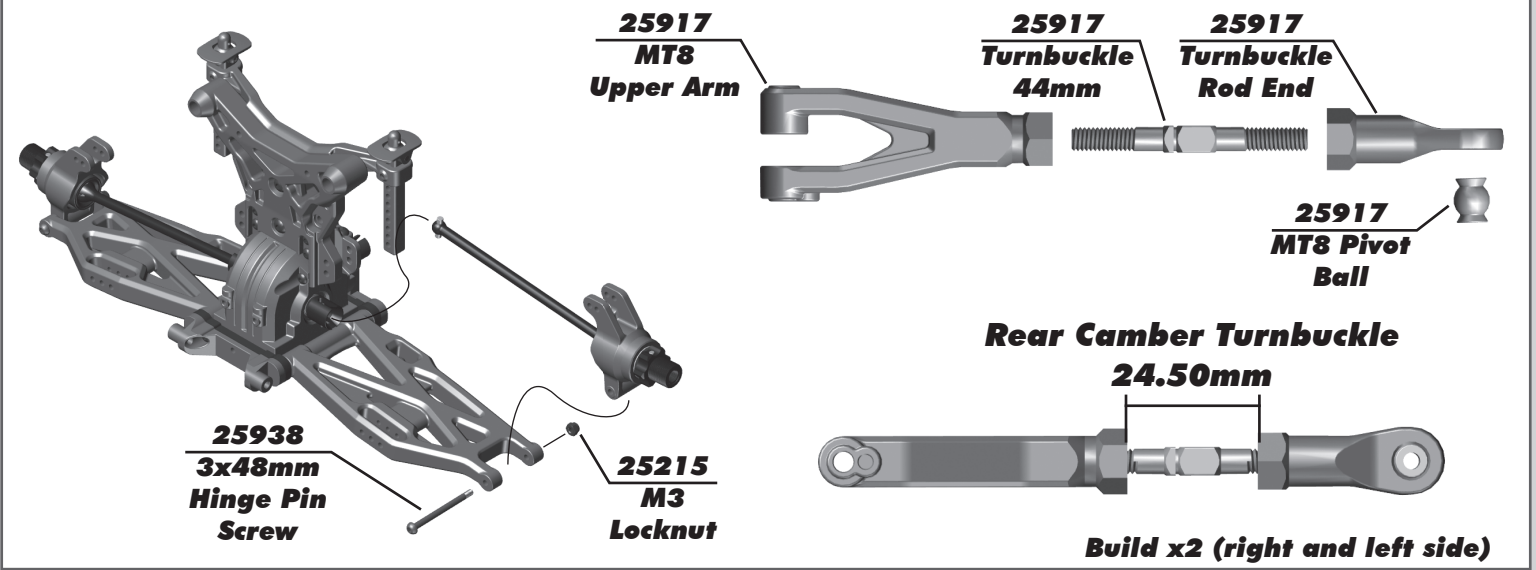

:: Step 21

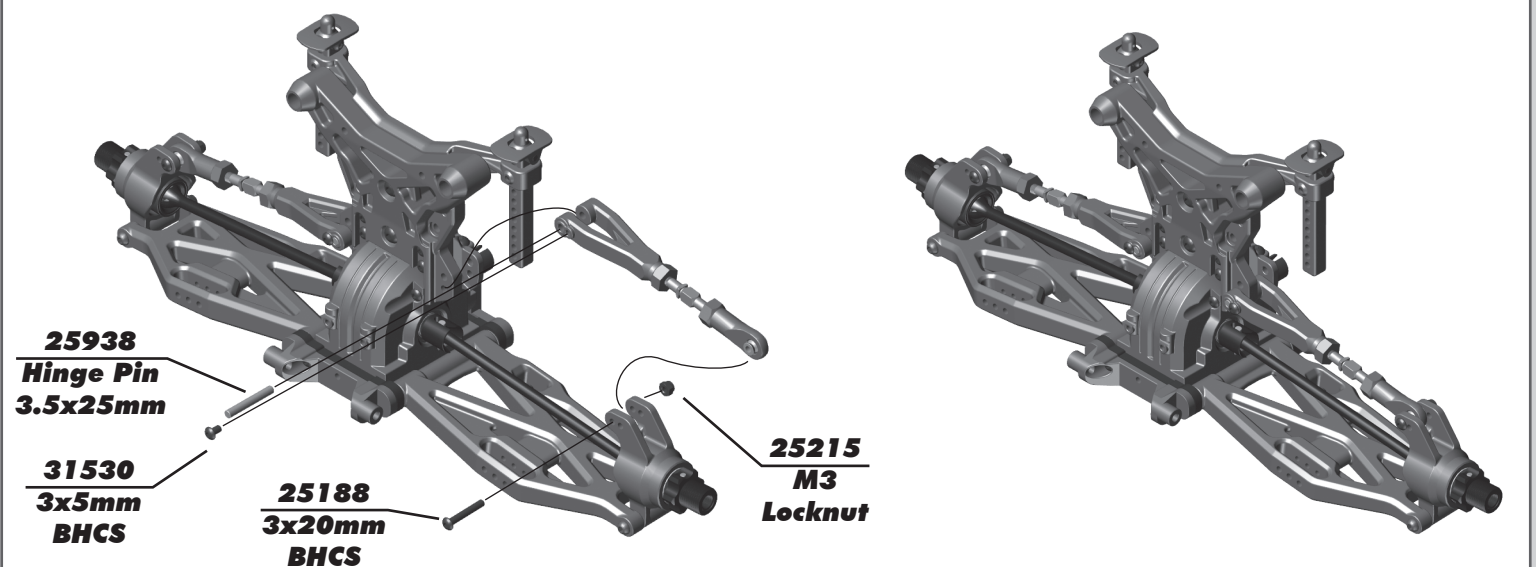

:: Step 22

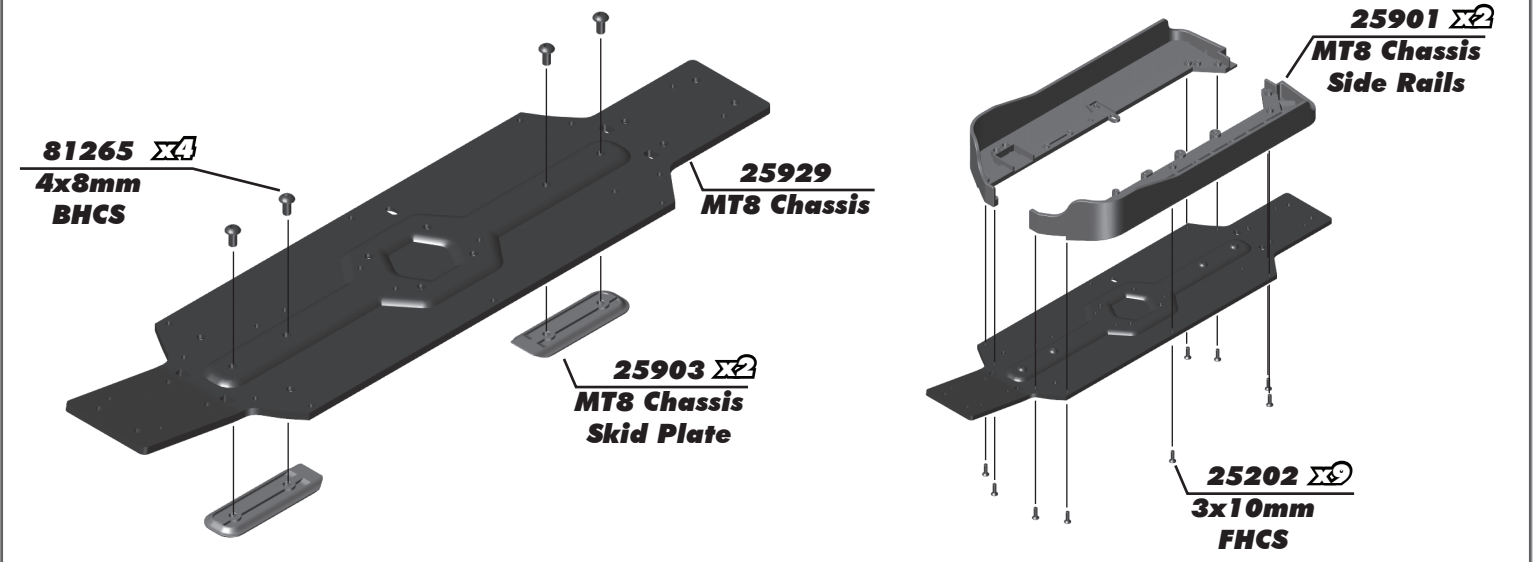

:: Step 23

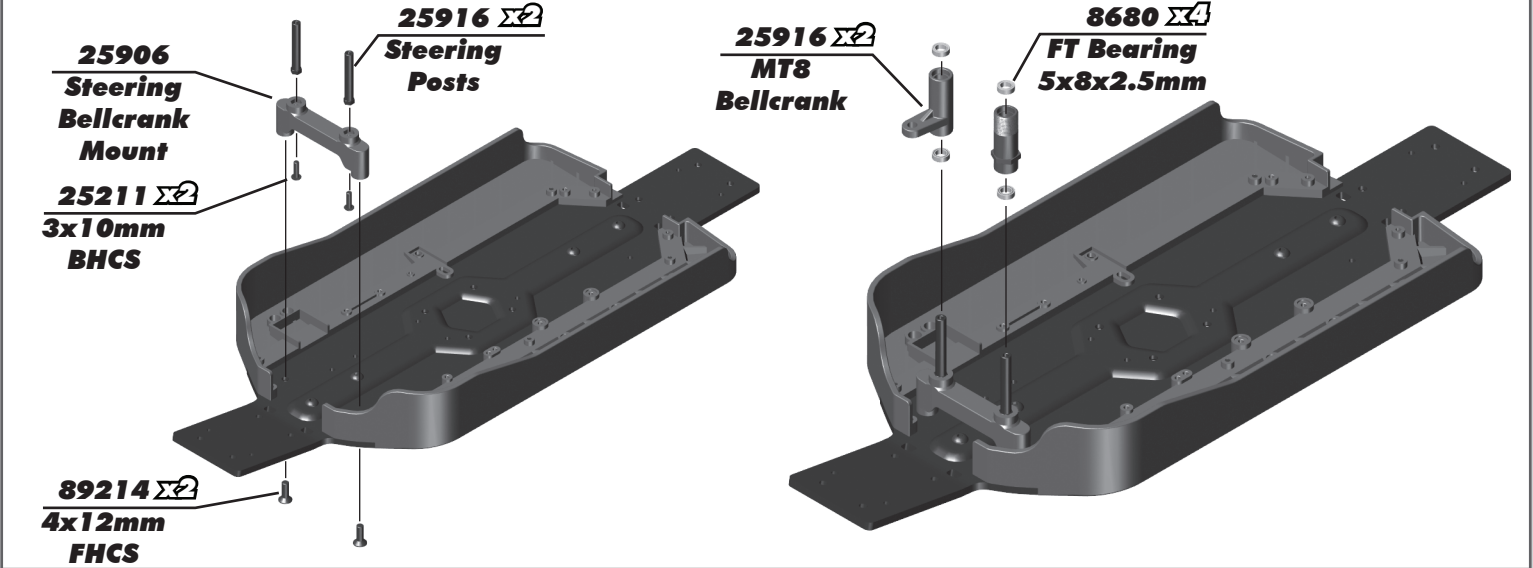

:: Step 24

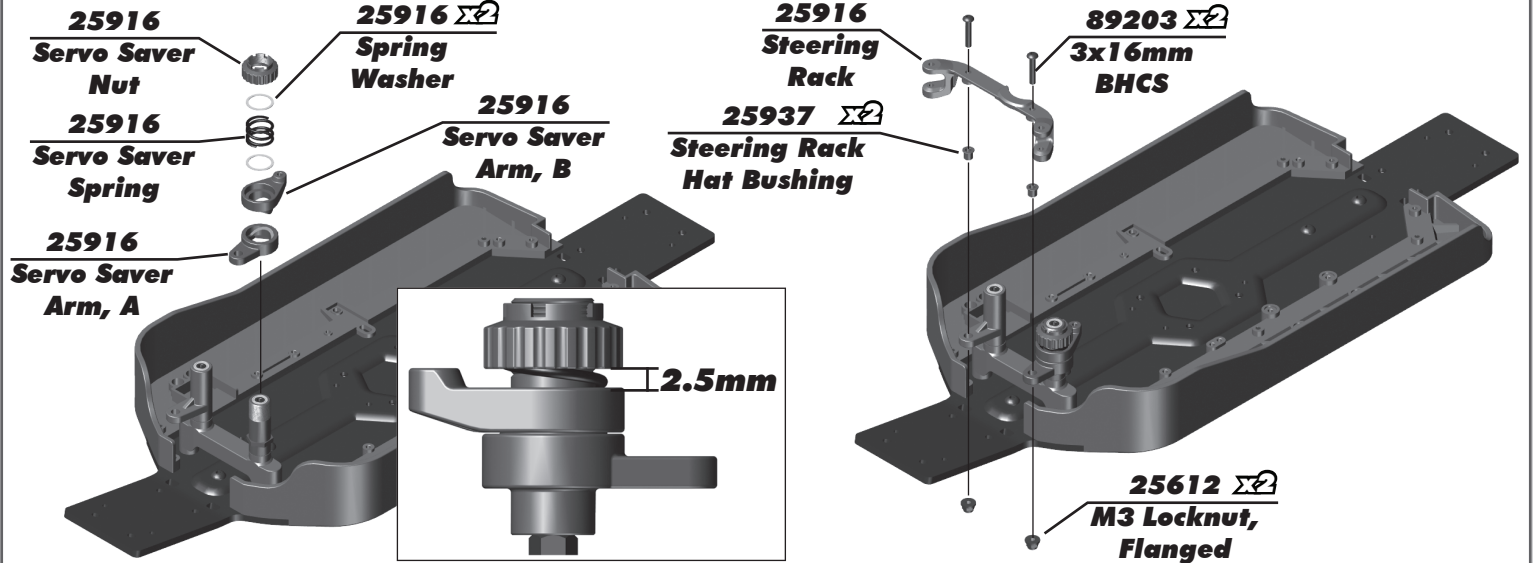

:: Step 25

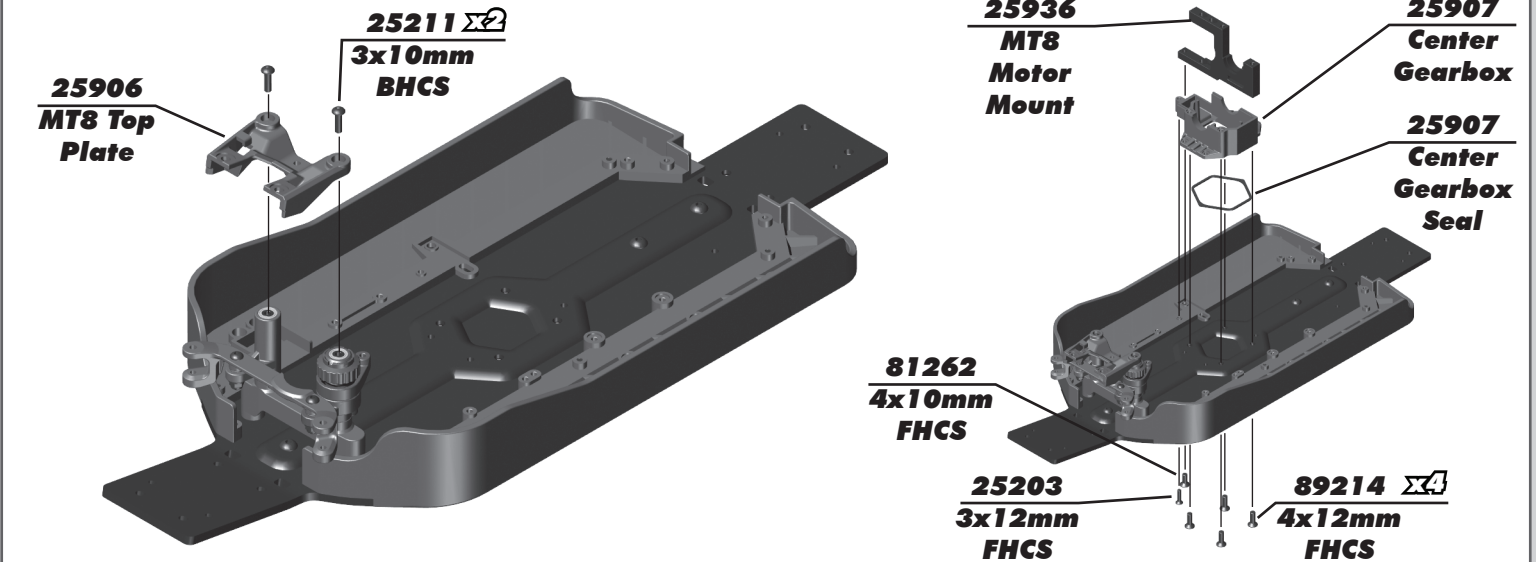

:: Step 26

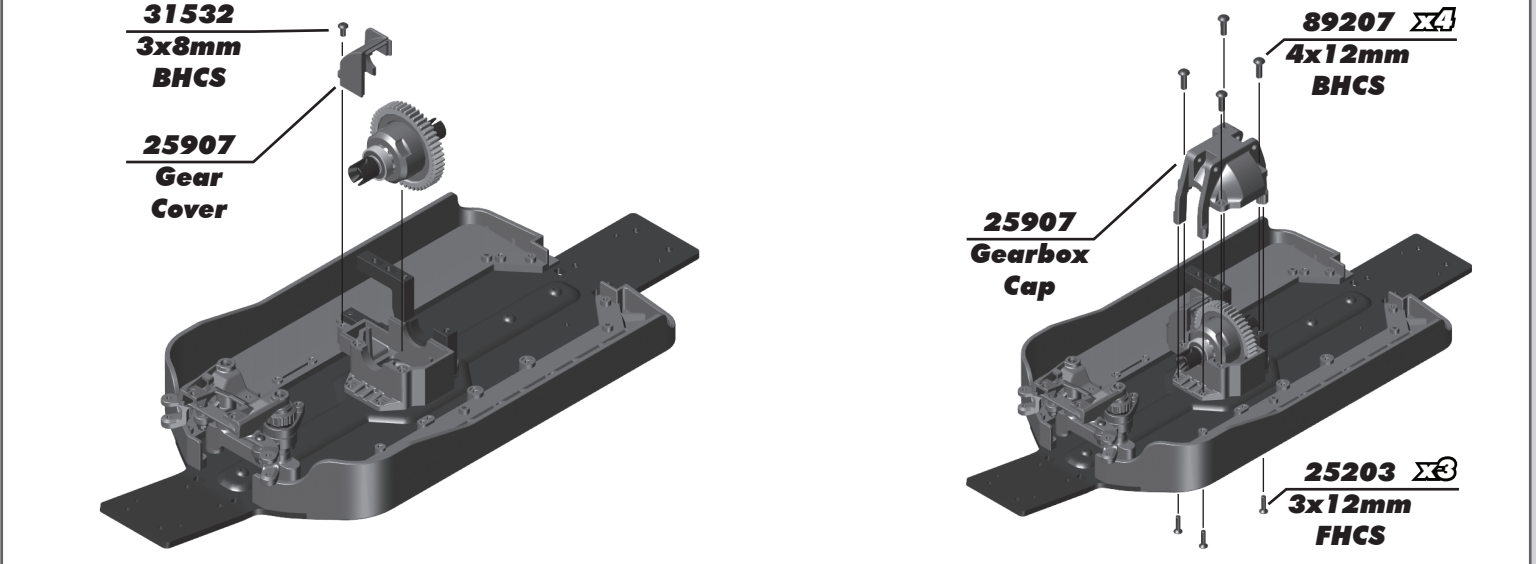

:: Step 27

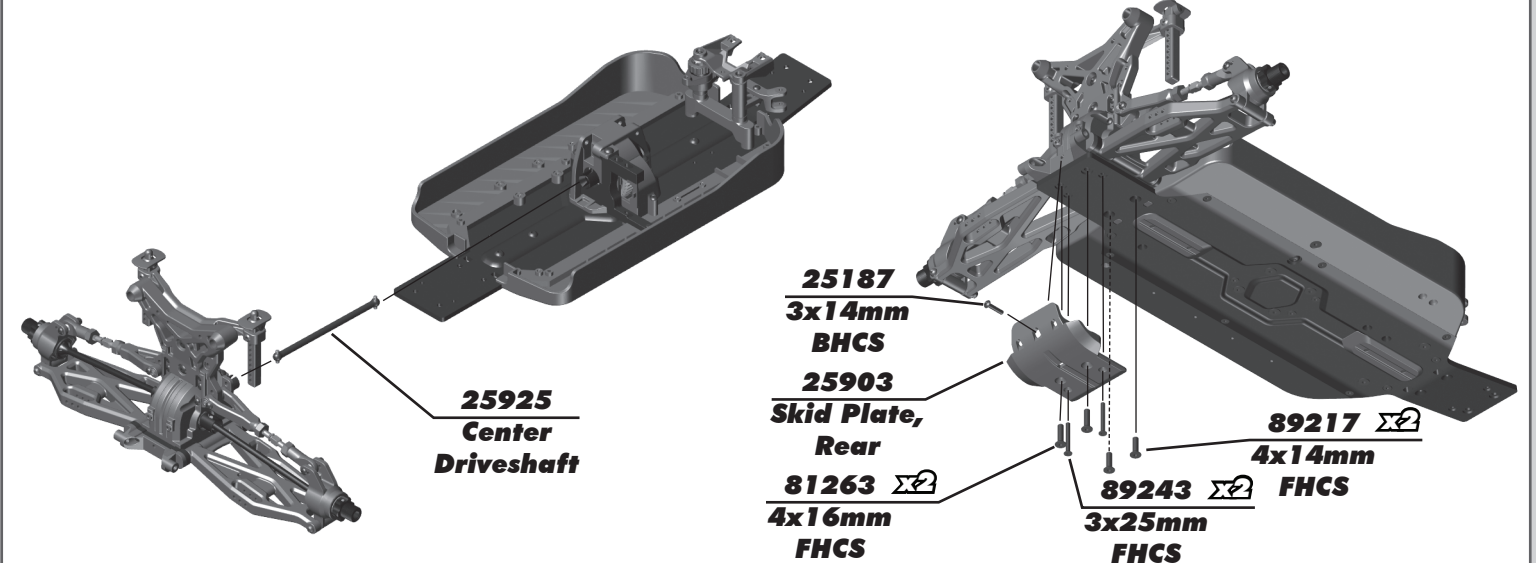

:: Step 28

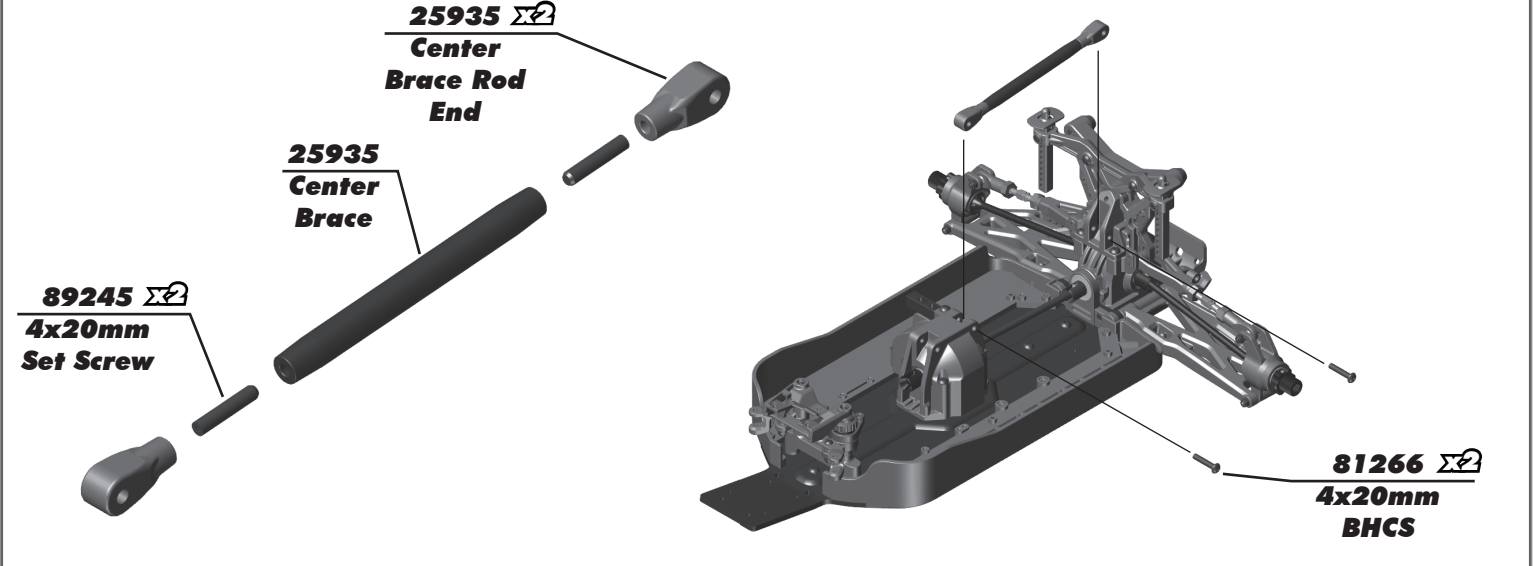

:: Step 29

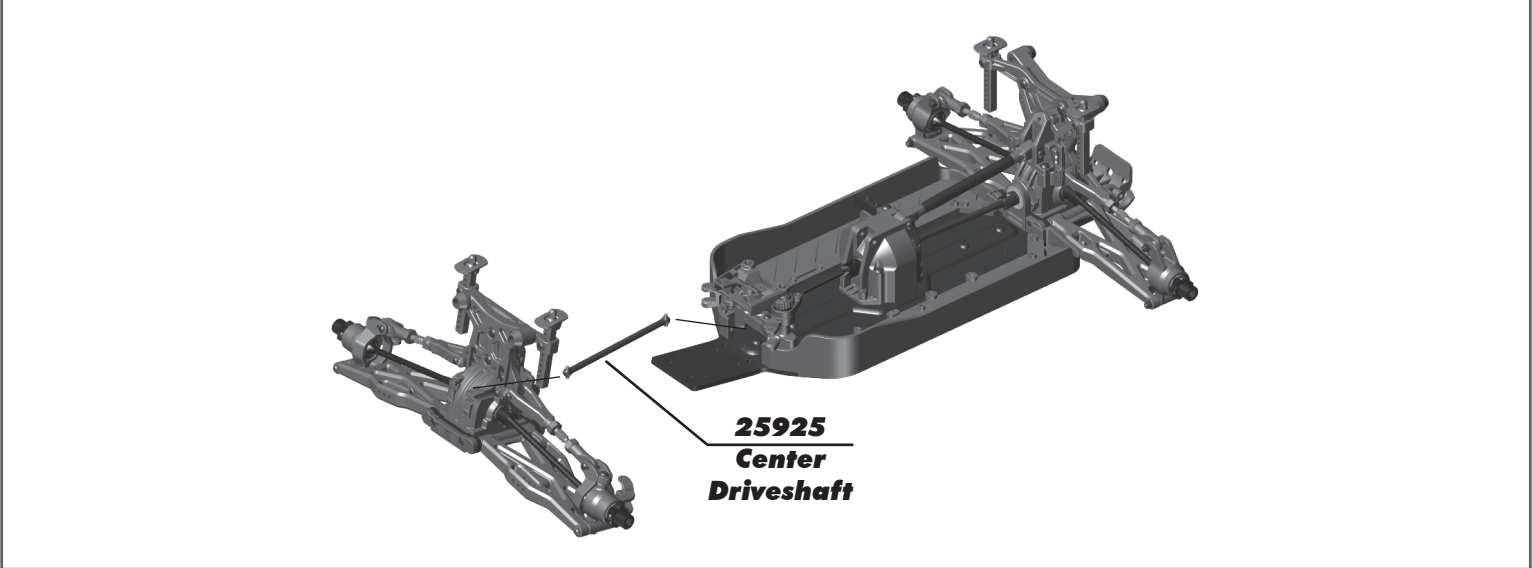

:: Step 30

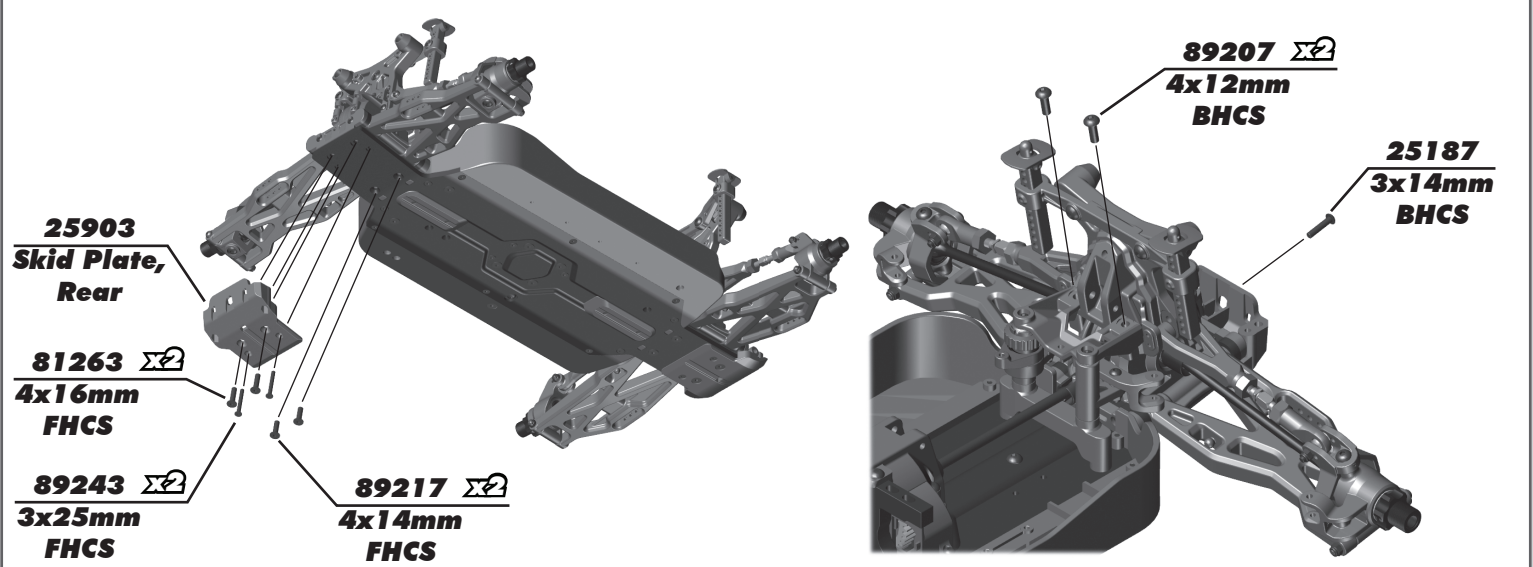

:: Step 31

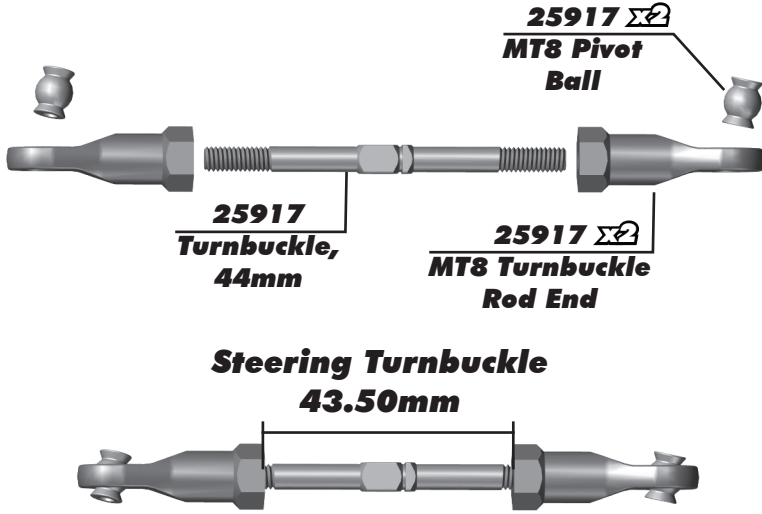

Build x2 (right and left side)

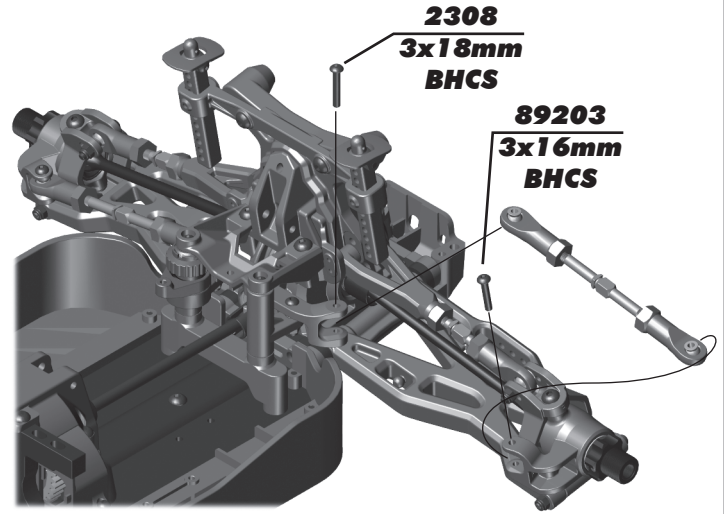

:: Step 32

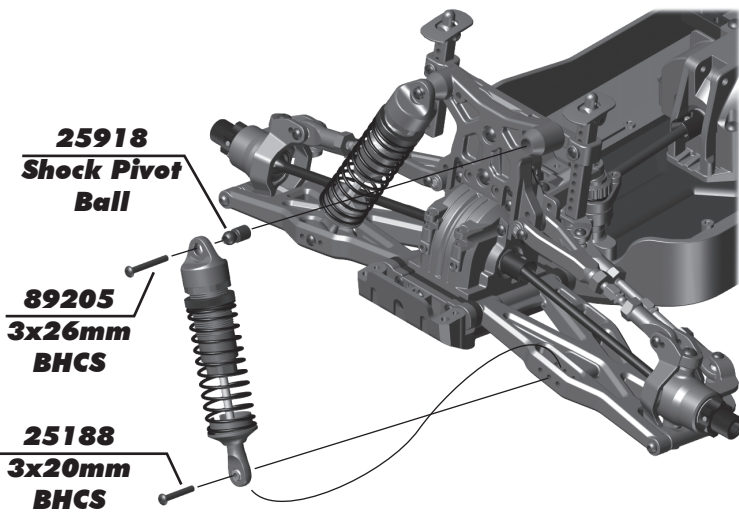

Build x2 (right and left side)

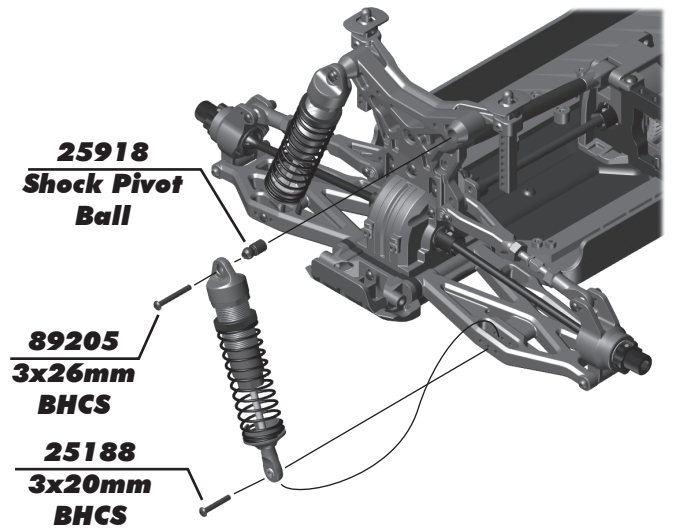

:: Step 33

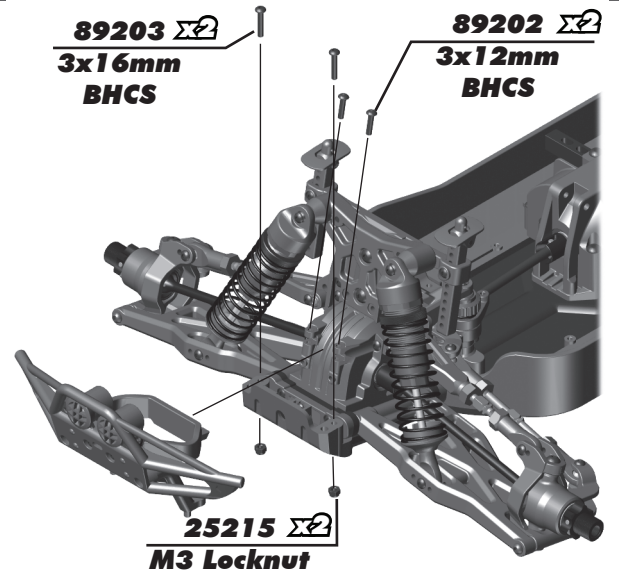
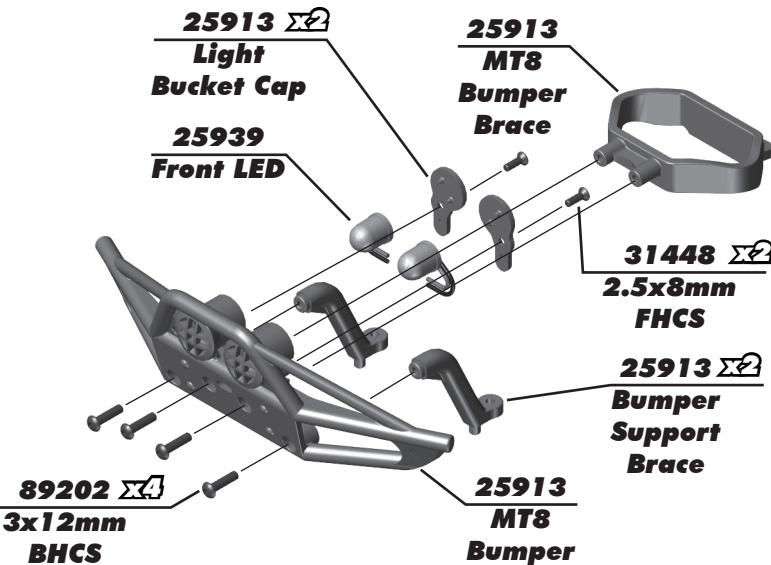

:: Step 34

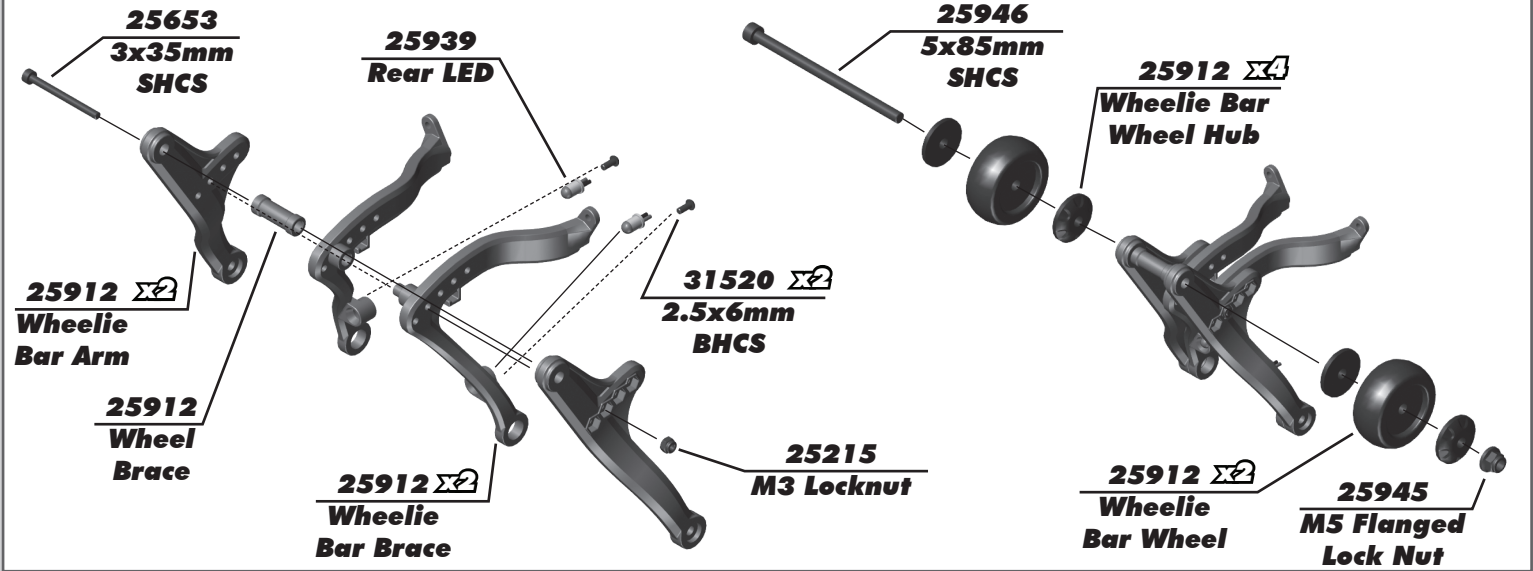

:: Step 35

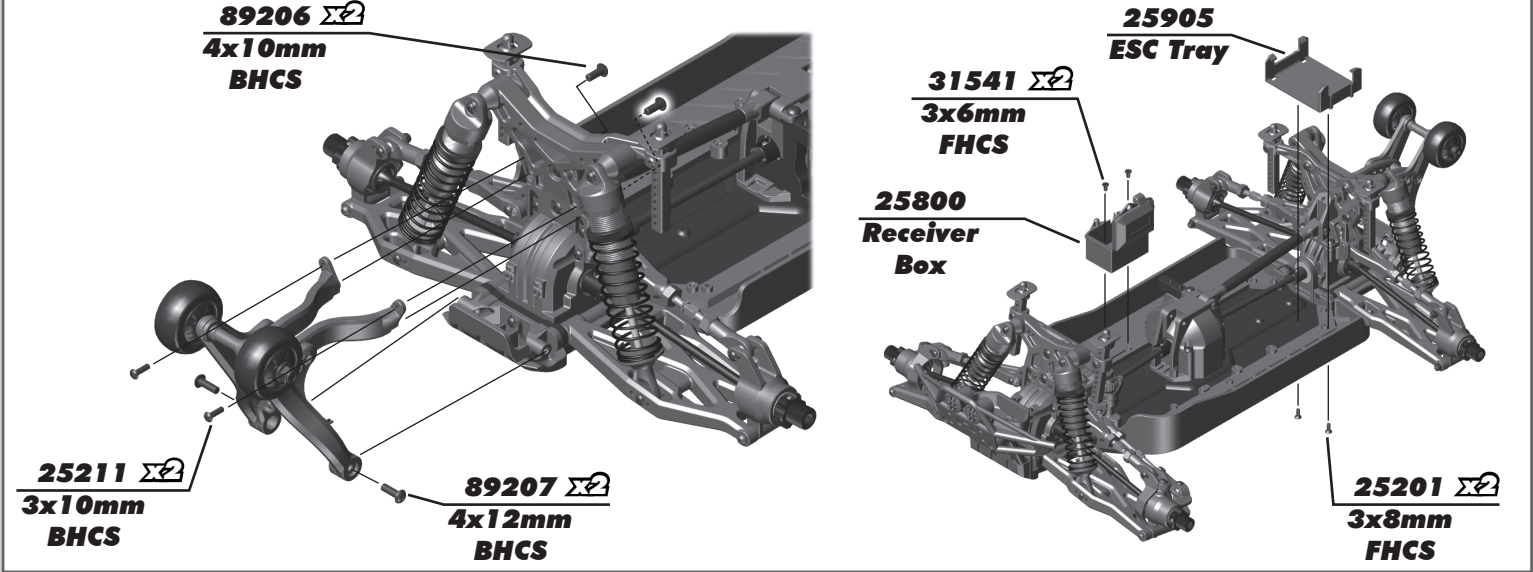

:: Step 36

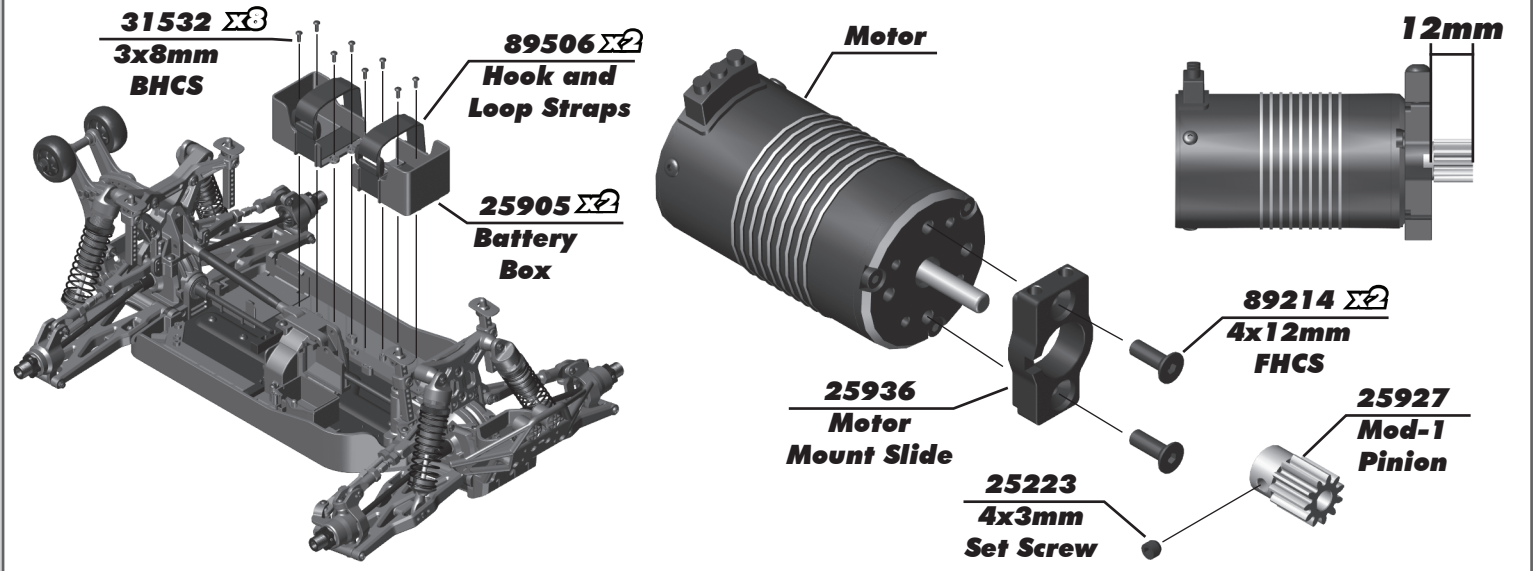

:: Step 37

25914
Wire Loop

31532
3x8mm
BHCS

81261 $\Sigma 2$
4x16mm
BHCS

81261
4x16mm
BHCS

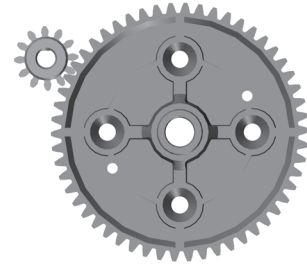
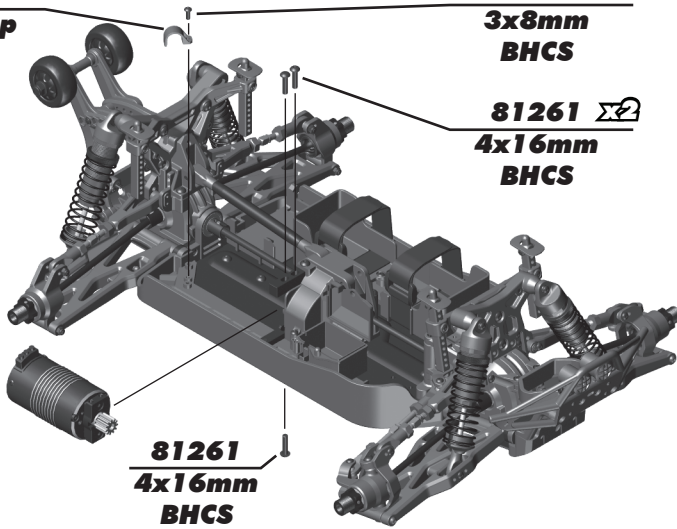

Set The Gear Mesh:

To set the gear mesh, rock the spur gear back and forth without making the pinion gear move. Excessive amounts of spur gear movement (loose gear mesh) will cause premature gear failure. If the spur gear mesh is tight, there will be no movement between the spur and pinion gears. A gear mesh that is too tight or too loose will reduce power and damage the gear teeth.

:: Step 38

25906
Servo
Mount

31532 $\Sigma 4$
3x8mm
BHCS

Servo

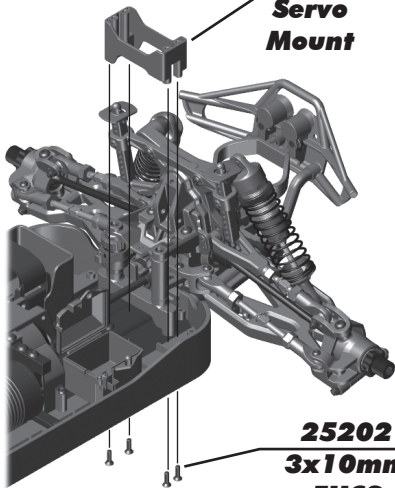

25202 $\Sigma 4$
3x10mm
FHCS

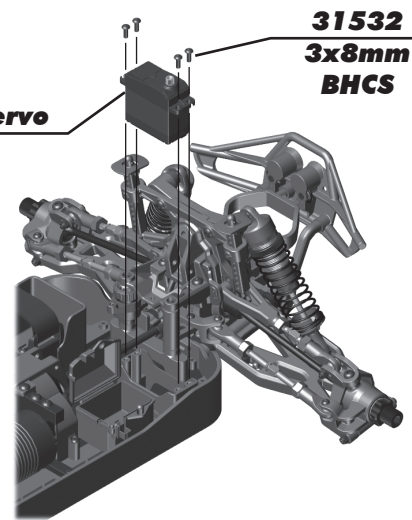

:: Step 39

25917 $\Sigma 2$
MT8 Pivot
Ball

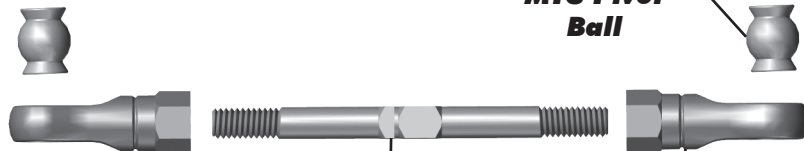

25917
Turnbuckle,
50mm

25917 $\Sigma 2$
MT8 Turnbuckle
Rod End

Servo Turnbuckle
30.50mm



31532
3x8mm
BHCS

25187 $\Sigma 2$
3x14mm
BHCS

25930
Servo
Horn

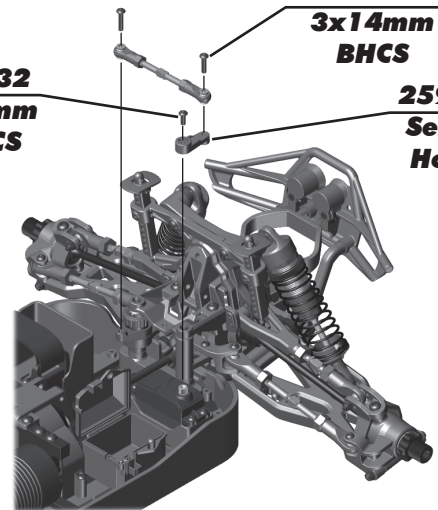

:: Step 40

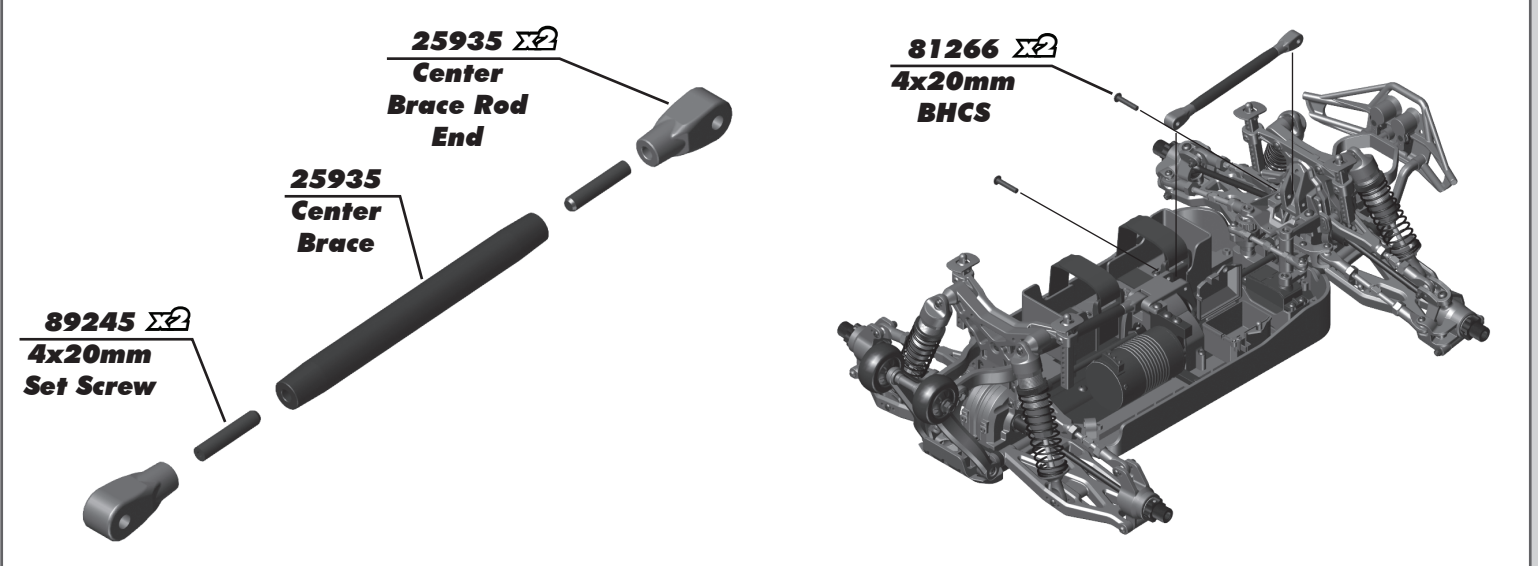

:: Step 41

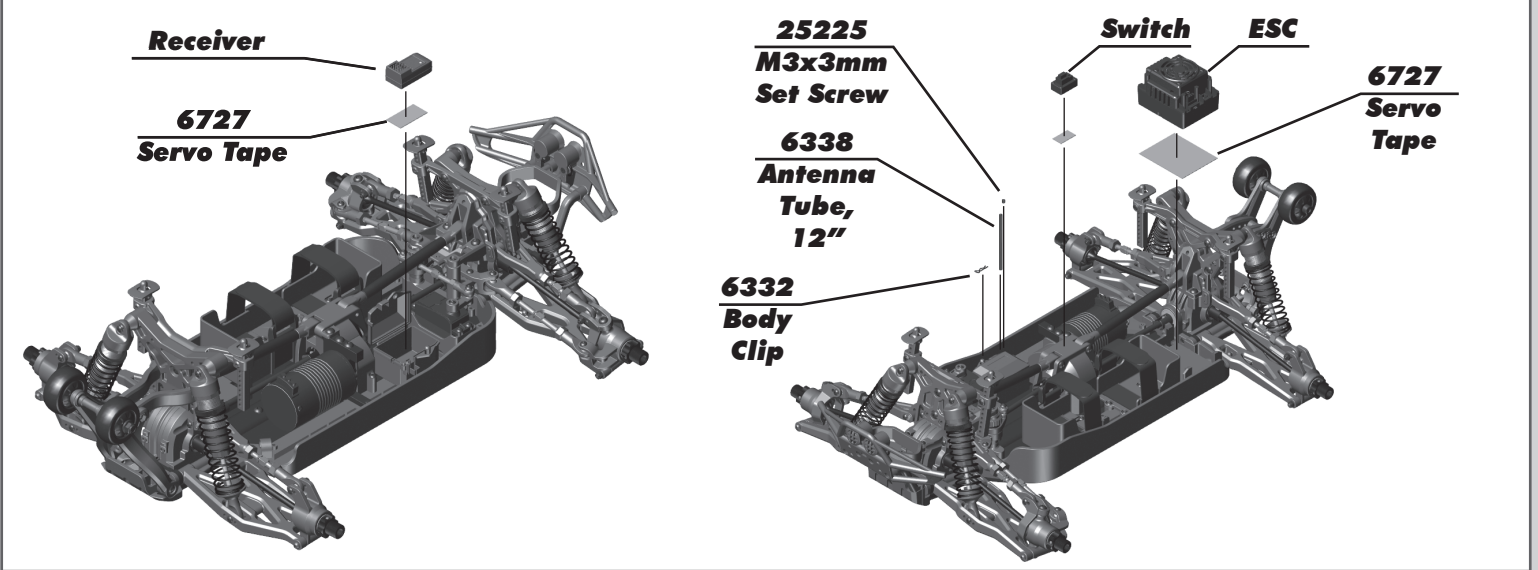

:: Step 42

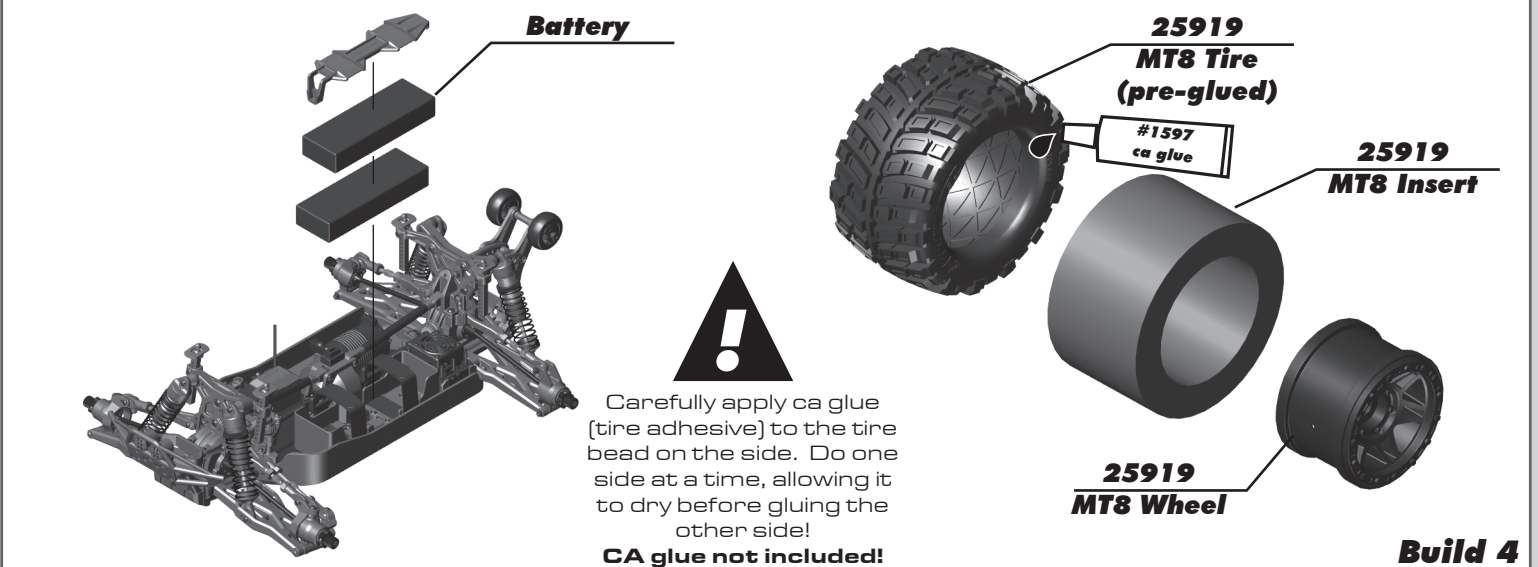

:: Step 43

Install 4

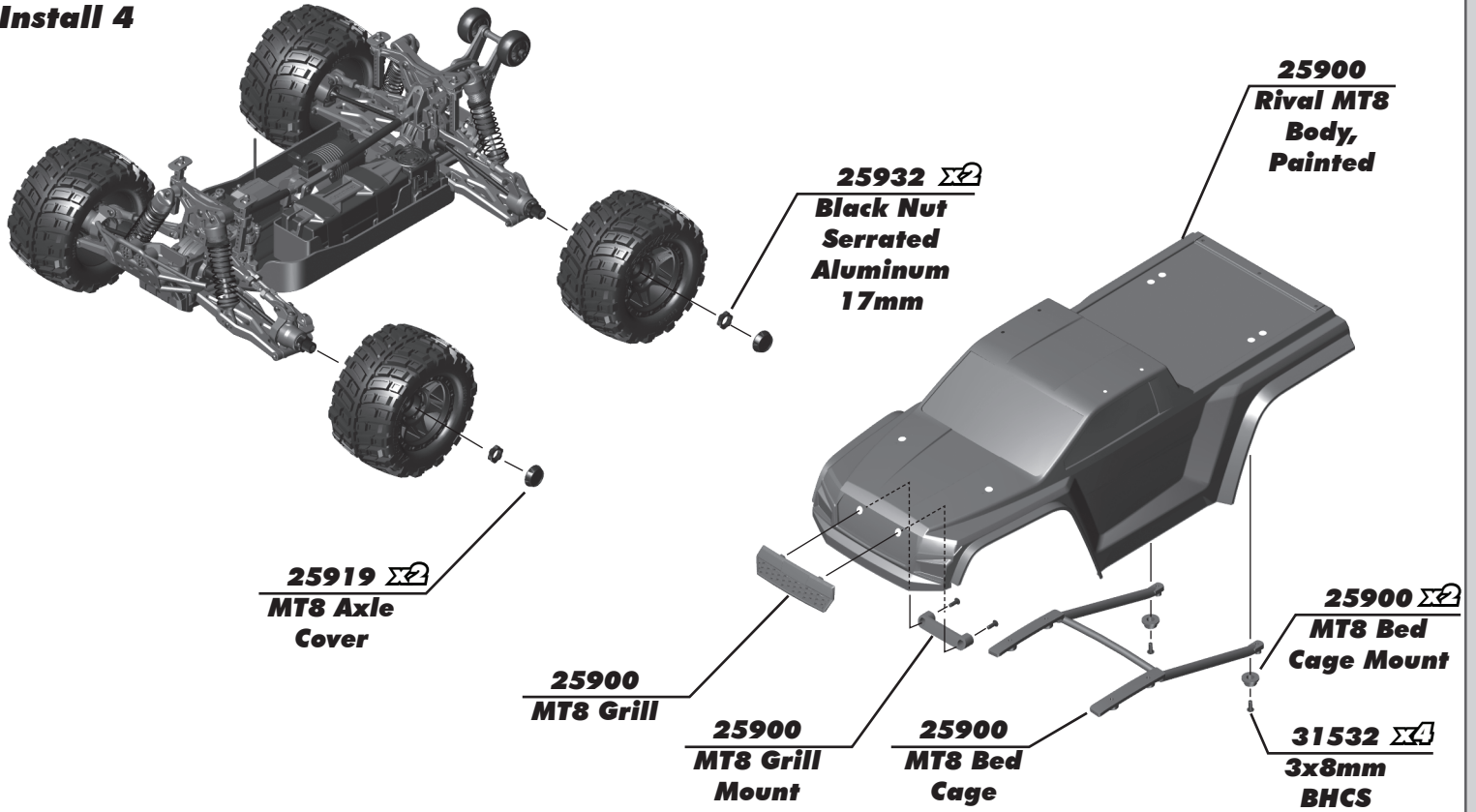

:: Step 44

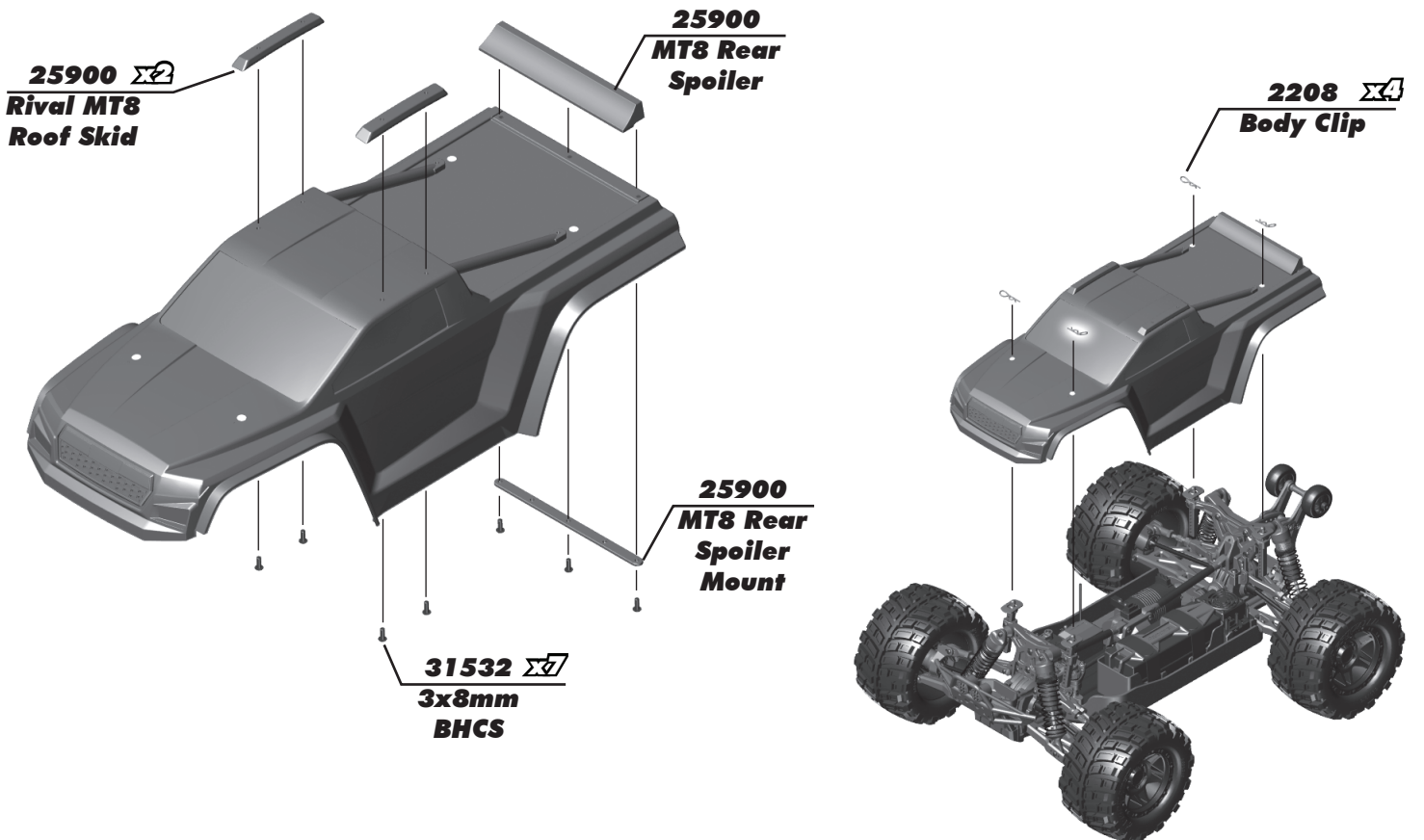

:: Tuning Tips

Tips for Beginners:

Before making any changes to the standard setup, make sure you can get around the track without crashing. Changes to your vehicle will not be beneficial if you can't stay on the track. Your goal is consistent laps. Once you can get around the track consistently, start tuning your vehicle. Make only ONE adjustment at a time, testing it before making another change. If the result of your adjustment is a faster lap, mark the change on the included setup sheet (make additional copies of the sheet before writing on it). If your adjustment results in a slower lap, revert back to the previous setup and try another change. When you are satisfied with your vehicle, fill in the setup sheet thoroughly and file it away. Use this as a guide for future track days or conditions. Periodically check all moving suspension parts. Suspension components must be kept clean and move freely without binding to prevent poor and/or inconsistent handling.

Set The Gear Mesh:

You should be able to rock the spur gear back and forth in the teeth of the pinion gear without making the pinion gear move. If the spur gear mesh is tight, then loosen the #81261 screw and move the motor away, then try again. A gear mesh that is too tight or too loose will reduce power and damage the gear teeth.

Front Camber:

Camber describes the angle at which the tire and wheel rides when looked at from the front. Negative camber means that the tire leans inward at the top. A good starting camber setting is -1° . Positive camber, where the top of the tire is leaning out, is not recommended.

Rear Camber:

Camber describes the angle at which the tire and wheel rides when looked at from the back. Negative camber means that the tire leans inward at the top. A good starting camber setting is -1° . Adding a small amount of positive camber, where the top of the tire is leaning out, will tend to improve straight-line acceleration on loose tracks.

Front Camber Links:

Changing the length of the camber link is considered a bigger step than adjusting the ball end height on the tower. Shortening the camber link (or lowering the ball end) will give the front end less roll and quicken steering response. Lengthening the camber link (or raising the ball end) will give the front more roll and slower steering response. Longer camber links are typically used on high grip tracks and shorter links tend to work better on medium-grip loose tracks.

Rear Camber Link:

Changing the length of the camber link is considered a bigger step than adjusting the ball end height on the rear chassis brace. Shortening the camber link (or lowering the ball end) will give the rear end less roll and the car will tend to accelerate or "square up" better. Lengthening the camber link (or raising the ball end) will give the rear more roll and more cornering grip. Longer camber links are typically used on high grip tracks, while shorter links tend to work better on medium grip loose tracks. The kit setting is the best compromise of cornering grip and acceleration.

Ackermann:

Ackermann is the angle difference between the front wheels when they are turned to steer the car. For minimal tire slip, it is standard for the inside wheel to steer to a greater angle than the outside wheel. If corner entry steering is too aggressive, try increasing the Ackermann by moving the ball studs to the rearward holes. Increasing the Ackermann will increase the angle difference of the front wheels when steered, resulting in a more stable car on corner entry.

TEAM ASSOCIATED

WORLD CHAMPION R / C CARS

Associated Electrics, Inc.
21062 Bake Parkway Lake Forest, CA 92630 USA

call: (949) 544-7500 - fax: (949) 544-7501

**Check out the following web sites for all of our kits,
current products, new releases, setup help, tips, and racing info!**
www.AssociatedElectrics.com

FOLLOW US ON SOCIAL MEDIA



TeamAssociated
ReedyPower
ElementRC



@TeamAssociatedRC
@ReedyPower
@Element_RC



@Team_Associated
@ReedyPower



AEFactoryTeam