



Fly First Class™

Tango 40 ARF

ASSEMBLY MANUAL



Specifications

Wingspan..... 48.2 in (1225mm)
 Wing Area 747 sq in (48.2 sq dm)
 Length..... 49.4 in (1255mm)
 Weight..... 5.5–6.5 lb (2.5 kg–2.95 kg)

Engine..... .56–.82 Four-Stroke
40–.52 Two-Stroke
 Power 46 Electric
 Radio..... 4-Channel w/5 Servos (4 for electric)

Table of Contents

Using the Manual	3
Required Tools and Adhesives	3
UltraCote Covering Colors	3
Before Starting Assembly	3
Radio and Power Systems Requirements	4
Recommended JR, JR SPORT and Spektrum Systems	4
Recommended Setup—Glow	4
Recommended Setup—Electric	4
FS One	4
Field Equipment	4
Warranty Period	5
Limited Warranty	5
Damage Limits	5
Safety Precautions	5
Questions, Assistance, and Repairs	6
Inspection or Repairs	6
Warranty Inspection and Repairs	6
Non-Warranty Repairs	6
Safety, Precautions, and Warnings	7
Contents of Kit	7
Section 1: Aileron Servo Installation	8
Section 2: Landing Gear and Tail Installation	11
Section 3A: Two-Stroke Engine Installation	13
Section 3B: Electric Motor Installation	17
Section 4: Final Assembly	20
Control Throws	22
Recommended Center of Gravity (CG)	22
Pre-Flight	23
Adjusting the Engine	23
Range Test Your Radio	23
Maintaining Your Tango 40 ARF	24
Glossary of Terms	25
2007 Official AMA National Model Aircraft Safety Code	26–27

Using the Manual

This manual is divided into sections to help make assembly easier to understand, and to provide breaks between each major section. In addition, check boxes have been placed next to each step to keep track of each step completed. Steps with a single box (☐) are performed once, while steps with two boxes (☐ ☐) indicate that the step will require repeating, such as for a right or left wing panel, two servos, etc. Remember to take your time and follow the directions.

Required Tools and Adhesives

Tools

- Felt-tipped pen or pencil
- Adjustable wrench
- Hobby knife
- Phillips screwdriver (large)
- Ruler
- Soldering iron
- Hex wrench: 3/32-inch
- Drill bit: 1/16-inch (1.5mm), 5/64-inch (2mm), 9/64-inch (3.5mm)
- Flat screwdriver
- Drill
- Masking tape
- Phillips screwdriver (small)
- Sandpaper
- Solder

Adhesives

- Formiula 560 Canopy Glue (PAAPT56)
- Thin CA (cyanoacrylate) Glue (PAAPT07)
- Pacer Z-42 Threadlock (PAAPT42)
- CA Remover/Debonder (PAAPT16)

UltraCote Covering Colors

- Orange HANU877
- Deep Blue HANU873
- White HANU870

Before Starting Assembly

Before beginning the assembly of the Tango™ 40, remove each part from its bag for inspection. Closely inspect the fuselage, wing panels, rudder, and stabilizer for damage. If you find any damaged or missing parts, contact the place of purchase.

If you find any wrinkles in the covering, use a heat gun or sealing iron to remove them. Use caution while working around areas where the colors overlap to prevent separating the colors.



HAN101 – Sealing Iron

**HAN141 – Sealing Iron
Sock**



HAN100 – Heat Gun

HAN150 – Covering Glove

Radio and Power Systems Requirements

- 4-channel radio system (minimum) w/Receiver
- JR Standard Switch (JSP98010)
- 18-inch Servo Lead Extension (JSP98120) (2)
- Y-harness (Ailerons) (JSP98020) (Required when using 4-channel radio) or 6-inch Servo Lead Extension (JSP98110) (2) when mixing ailerons through the radio
- ST47 Standard Servo (JSP20050) (5) or equivalent (4 when building electric version)
- Large Servo Arms (JSP98060) (3 pkgs)
- 700mAh Ni-Cd 4-cell (JSP91010)

Recommended JR, JR SPORT and Spektrum Systems

- XP9303
- XP7202
- DX7
- XP6102
- XS600



JR XP9303



Spektrum DX7



JR XP7202

Recommended Setup—Glow

- Evolution® .52NX with Muffler (EVOE0520)
- Evolution Propeller 11 x 5 (EVO11050) to 11 x 6 (EVO11060)



Evolution .52NX
EVOE0520

Recommended Setup—Electric

- E-flite® Power 46 BL Outrunner Motor (EFLM4046A)
- Castle Creations 60A ESC (CSEPHX60)
- Thunder Power 4S 3850–4500mAh Li-Po Battery Pack
- APC Propeller 13x6.5-inch (APC13065E) to 14x7 (APC14070E)



Power 46 Brushless
Outrunner Motor,670KV
EFLM4046A

FS One

With FS One® you get more than photorealistic fields, gorgeous skies and realistic-looking aircraft. You get incredibly advanced aerodynamic modeling that simulates every possible aspect of real-world flight.



HANS2000

Field Equipment

- Propeller
- Glow Plug Wrench (HAN2510)
- Glow Plug (EVOGP1)
- Fuel
- Glow Plug Igniter w/charger(HAN7101)
- Manual Fuel Pump (HAN118)

Warranty Period

Exclusive Warranty- Horizon Hobby, Inc., (Horizon) warrants that the Products purchased (the "Product") will be free from defects in materials and workmanship at the date of purchase by the Purchaser.

Limited Warranty

(a) This warranty is limited to the original Purchaser ("Purchaser") and is not transferable. REPAIR OR REPLACEMENT AS PROVIDED UNDER THIS WARRANTY IS THE EXCLUSIVE REMEDY OF THE PURCHASER. This warranty covers only those Products purchased from an authorized Horizon dealer. Third party transactions are not covered by this warranty. Proof of purchase is required for warranty claims. Further, Horizon reserves the right to change or modify this warranty without notice and disclaims all other warranties, express or implied.

(b) Limitations- HORIZON MAKES NO WARRANTY OR REPRESENTATION, EXPRESS OR IMPLIED, ABOUT NON-INFRINGEMENT, MERCHANTABILITY OR FITNESS FOR A PARTICULAR PURPOSE OF THE PRODUCT. THE PURCHASER ACKNOWLEDGES THAT THEY ALONE HAVE DETERMINED THAT THE PRODUCT WILL SUITABLY MEET THE REQUIREMENTS OF THE PURCHASER'S INTENDED USE.

(c) Purchaser Remedy- Horizon's sole obligation hereunder shall be that Horizon will, at its option, (i) repair or (ii) replace, any Product determined by Horizon to be defective. In the event of a defect, these are the Purchaser's exclusive remedies. Horizon reserves the right to inspect any and all equipment involved in a warranty claim. Repair or replacement decisions are at the sole discretion of Horizon. This warranty does not cover cosmetic damage or damage due to acts of God, accident, misuse, abuse, negligence, commercial use, or modification of or to any part of the Product. This warranty does not cover damage due to improper installation, operation, maintenance, or attempted repair by anyone other than Horizon. Return of any goods by Purchaser must be approved in writing by Horizon before shipment.

Damage Limits

HORIZON SHALL NOT BE LIABLE FOR SPECIAL, INDIRECT OR CONSEQUENTIAL DAMAGES, LOSS OF PROFITS OR PRODUCTION OR COMMERCIAL LOSS IN ANY WAY CONNECTED WITH THE PRODUCT, WHETHER SUCH CLAIM IS BASED IN CONTRACT, WARRANTY, NEGLIGENCE, OR STRICT LIABILITY. Further, in no event shall the liability of Horizon exceed the individual price of the Product on which liability is asserted. As Horizon has no control over use, setup, final assembly, modification or misuse, no liability shall be assumed nor accepted for any resulting damage or injury. By the act of use, setup or assembly, the user accepts all resulting liability.

If you as the Purchaser or user are not prepared to accept the liability associated with the use of this Product, you are advised to return this Product immediately in new and unused condition to the place of purchase.

Law: These Terms are governed by Illinois law (without regard to conflict of law principals).

Safety Precautions

This is a sophisticated hobby Product and not a toy. It must be operated with caution and common sense and requires some basic mechanical ability. Failure to operate this Product in a safe and responsible manner could result in injury or damage to the Product or other property. This Product is not intended for use by children without direct adult supervision. The Product manual contains instructions for safety, operation and maintenance. It is essential to read and follow all the instructions and warnings in the manual, prior to assembly, setup or use, in order to operate correctly and avoid damage or injury.

Questions, Assistance, and Repairs

Your local hobby store and/or place of purchase cannot provide warranty support or repair. Once assembly, setup or use of the Product has been started, you must contact Horizon directly. This will enable Horizon to better answer your questions and service you in the event that you may need any assistance. For questions or assistance, please direct your email to productsupport@horizonhobby.com, or call 877.504.0233 toll free to speak to a service technician.

Inspection or Repairs

If this Product needs to be inspected or repaired, please call for a Return Merchandise Authorization (RMA). Pack the Product securely using a shipping carton. Please note that original boxes may be included, but are not designed to withstand the rigors of shipping without additional protection. Ship via a carrier that provides tracking and insurance for lost or damaged parcels, as **Horizon is not responsible for merchandise until it arrives and is accepted at our facility**. A Service Repair Request is available at www.horizonhobby.com on the "Support" tab. If you do not have internet access, please include a letter with your complete name, street address, email address and phone number where you can be reached during business days, your RMA number, a list of the included items, method of payment for any non-warranty expenses and a brief summary of the problem. Your original sales receipt must also be included for warranty consideration. Be sure your name, address, and RMA number are clearly written on the outside of the shipping carton.

Warranty Inspection and Repairs

To receive warranty service, you must include your original sales receipt verifying the proof-of-purchase date. Provided warranty conditions have been met, your Product will be repaired or replaced free of charge. Repair or replacement decisions are at the sole discretion of Horizon Hobby.

Non-Warranty Repairs

Should your repair not be covered by warranty the repair will be completed and payment will be required without notification or estimate of the expense unless the expense exceeds 50% of the retail purchase cost. By submitting the item for repair you are agreeing to payment of the repair without notification. Repair estimates are available upon request. You must include this request with your repair. Non-warranty repair estimates will be billed a minimum of ½ hour of labor. In addition you will be billed for return freight. Please advise us of your preferred method of payment. Horizon accepts money orders and cashiers checks, as well as Visa, MasterCard, American Express, and Discover cards. If you choose to pay by credit card, please include your credit card number and expiration date. Any repair left unpaid or unclaimed after 90 days will be considered abandoned and will be disposed of accordingly. **Please note: non-warranty repair is only available on electronics and model engines.**

Electronics and engines requiring inspection or repair should be shipped to the following address:

Horizon Service Center
4105 Fieldstone Road
Champaign, Illinois 61822

All other Products requiring warranty inspection or repair should be shipped to the following address:

Horizon Product Support
4105 Fieldstone Road
Champaign, Illinois 61822

Please call 877-504-0233 with any questions or concerns regarding this product or warranty.

Safety, Precautions, and Warnings

This model is controlled by a radio signal that is subject to interference from many sources outside your control. This interference can cause momentary loss of control so it is advisable to always keep a safe distance in all directions around your model, as this margin will help to avoid collisions or injury.

- Always operate your model in an open area away from cars, traffic, or people.
- Avoid operating your model in the street where injury or damage can occur.
- Never operate the model into the street or populated areas for any reason.
- Never operate your model with low transmitter batteries.
- Carefully follow the directions and warnings for this and any optional support equipment (chargers, rechargeable battery packs, etc.) that you use.
- Keep all chemicals, small parts and anything electrical out of the reach of children.
- Moisture causes damage to electronics. Avoid water exposure to all equipment not specifically designed and protected for this purpose.

Contents of Kit

Replacement Parts

A. HAN4601	Wing Set
B. HAN4602	Fuselage
C. HAN4603	Tail Set
D. HAN4604	Landing Gear w/o Wheels
E. HAN4607	Windshield

Items Not Shown

HAN4605	Decal Sheet
HAN4606	Pushrod Set

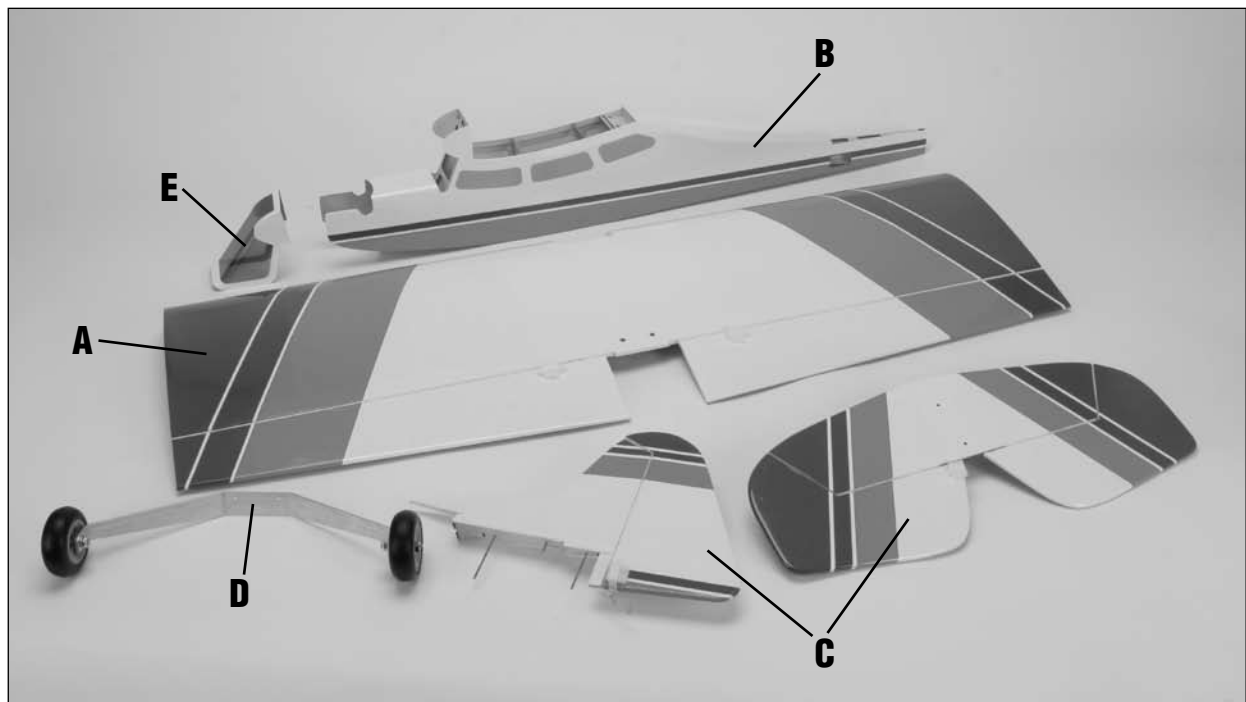

Section 1: Aileron Servo Installation

Required Parts

- Wing panel w/ailerons
- Servo w/hardware (2)
- Pre-assembled 3 1/2-inch (89mm) aileron linkage (2)

Required Tools and Adhesives

- Drill
- Thin CA
- Phillips screwdriver
- Long servo arm
- Drill bit: 1/16-inch (1.5mm)

□ □ Step 1

Check to make sure the hinges have been securely glued into place. Gently pull on each aileron to make sure the hinges are secure. Avoid too much pressure which could cause damage to the wing and aileron. Saturate each hinge if you find any that are loose.

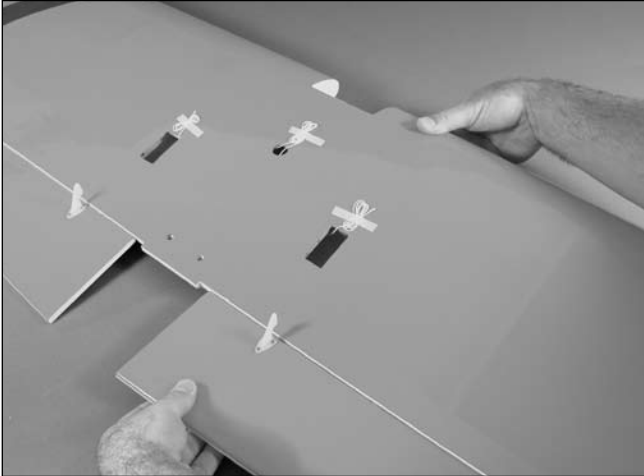

□ □ Step 2

Flex each aileron up and down a number of times to break in the hinges.

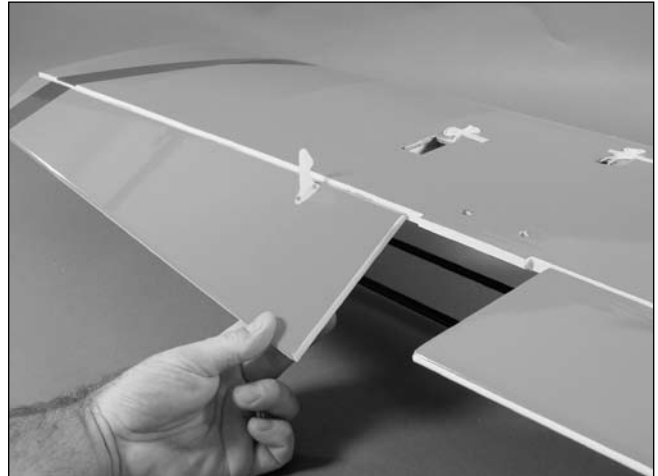
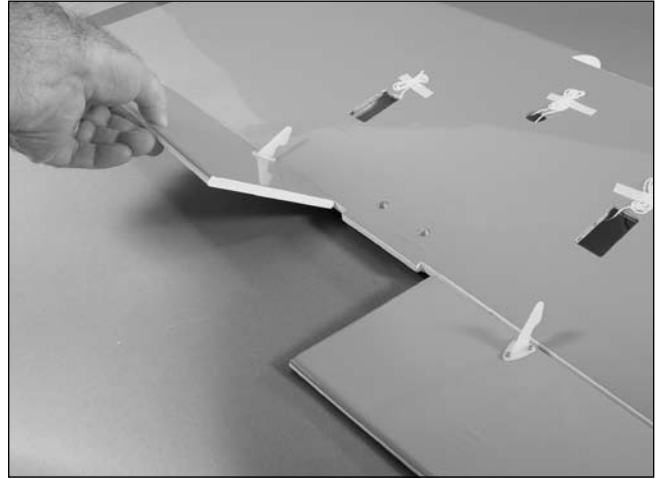

□ □ Step 3

Prepare an aileron servo by installing the grommets and brass eyelets provided with the servo.

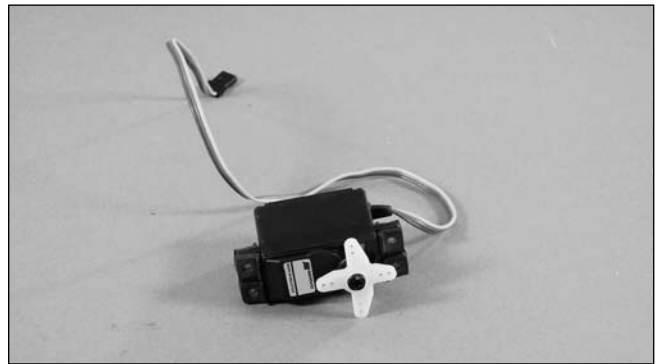

Section 1: Aileron Servo Installation

□ □ Step 4

Tie the string that exits the servo opening to the servo extension. Use the string to pull the servo lead through the wing.

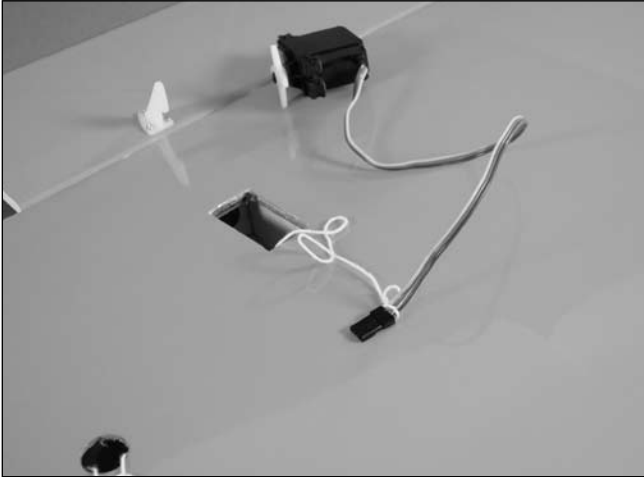

□ □ Step 5

Place the servo into the opening with the servo output arm towards the leading edge of the wing. Use a felt-tipped pen to mark the locations for the four servo mounting screws.



□ □ Step 6

Remove the servo and drill the locations for the servo mounting screws using a 1/16-inch (1.5mm) drill bit.

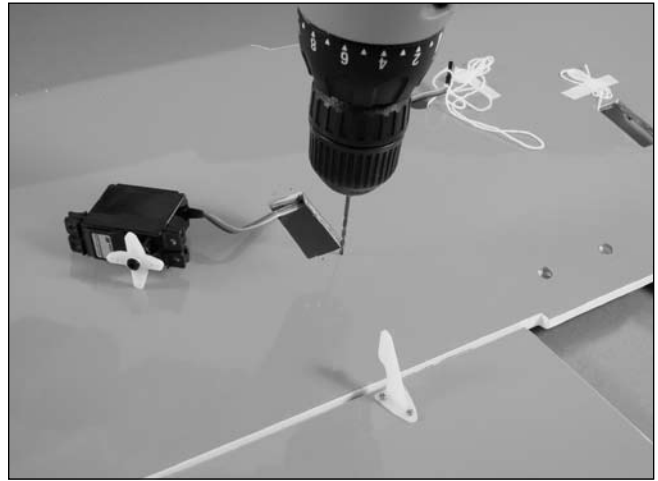

□ □ Step 7

Apply a couple drops of thin CA to each hole to harden the wood, which will help in preventing the screws from damaging the wood.

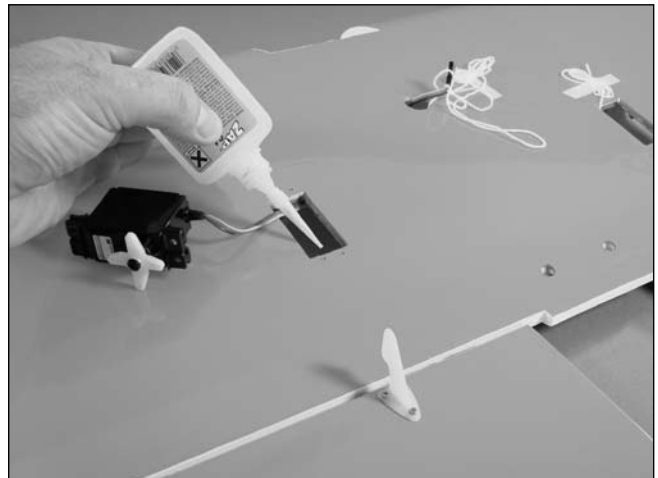

Section 1: Aileron Servo Installation

□ □ Step 8

Secure the servo using the screws provided with the servo. Remove the stock servo horn and install a long servo arm in its place. Remove the side of the arm that does not align with the control horn.

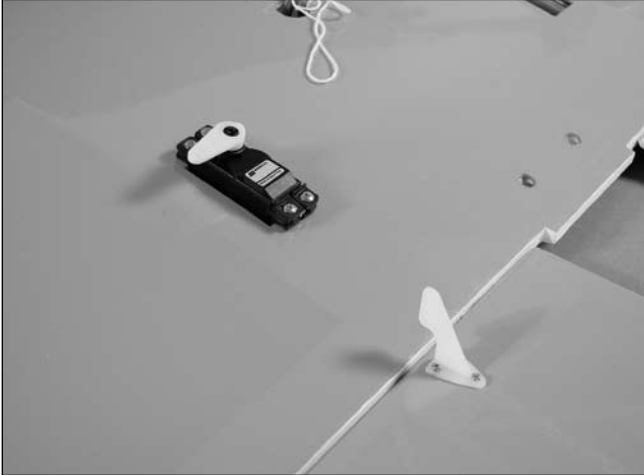

□ □ Step 9

Enlarge the outer hole of the servo arm using a 5/64-inch (2mm) drill bit. Remove the pushrod keeper from the linkage and slide the bend through the servo arm. Secure the pushrod to the servo arm by replacing the pushrod keeper.

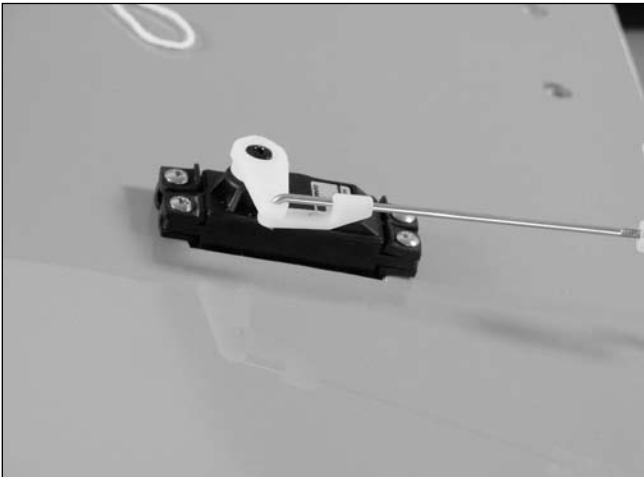

□ □ Step 10

Attach the clevis to the control horn. With the radio system on and the aileron trim and stick centered, check that the aileron is centered when viewed from the wing tip. Adjust the length of the linkage if necessary.

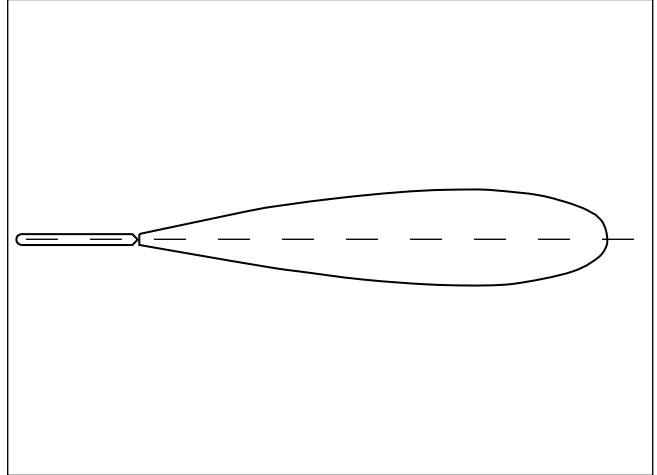

□ □ Step 11

Use tape on the servo lead to prevent it from falling back into the wing.

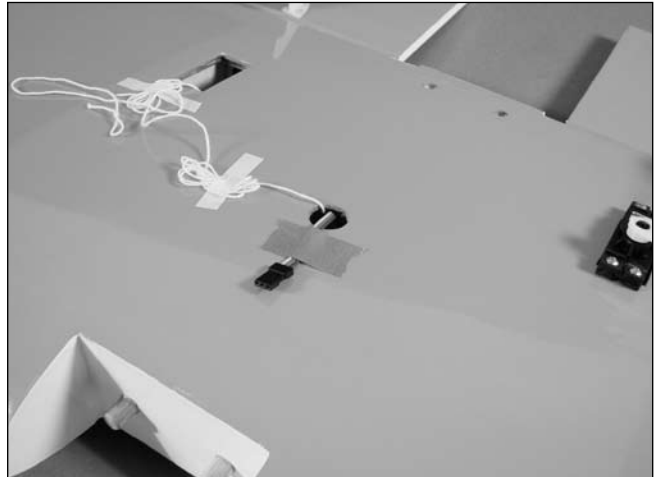

□ Step 12

Repeat Steps 1 through 11 for the remaining aileron servo.

Section 2: Landing Gear and Tail Installation

Required Parts

- Landing gear w/wheels
- 1-inch (25mm) tail wheel
- Stabilizer assembly
- #4 washer (large) (2)
- 5/64-inch wheel collar
- 6-32 x 3/4-inch machine screw (3)
- Pre-assembled 4 1/2-inch (114mm) linkage (2)
- Fuselage
- Rudder assembly
- 4-40 locknut (2)
- #6 washer (3)
- 4-40 setscrew

Required Tools and Adhesives

- Servo w/hardware (2)
- Adjustable wrench
- Threadlock
- 18-inch (458mm) servo extension (2)
- Long servo arm (2)

□ Step 1

Attach the landing gear to the bottom of the fuselage using three 6-32 x 3/4-inch machine screws and three #6 washers.

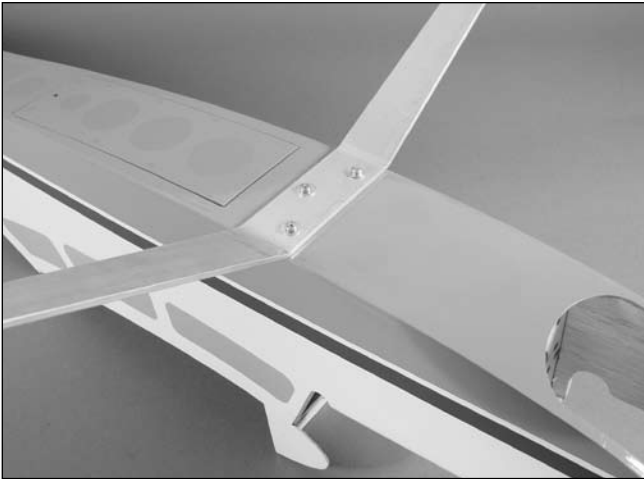

Note: Use threadlock on the screws to prevent them from vibrating loose in flight.

□ Step 2

Slide the threaded rods from the rudder assembly into the holes in the stabilizer. The two forward rods go through the stabilizer as shown.

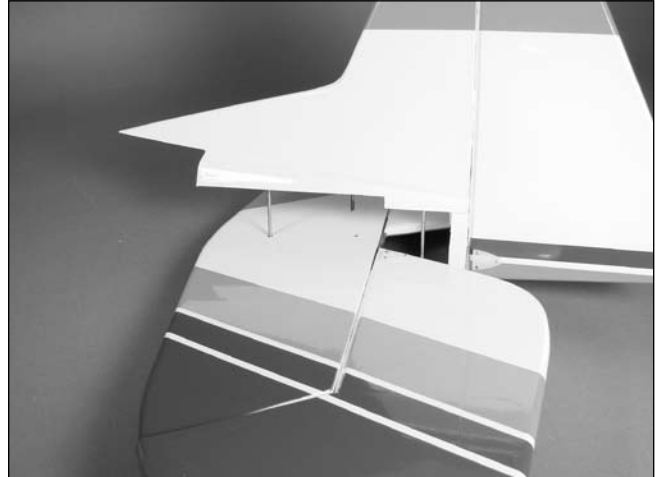

□ Step 3

Slide the rudder/stabilizer onto the fuselage. Guide the threaded rods through the stabilizer saddle then through the holes in the bottom of the fuselage.



Section 2: Landing Gear and Tail Installation

□ Step 4

Secure the tail assembly to the fuselage using two larger #4 washers and two 4-40 locknuts. Do not over-tighten the nuts and crush the fuselage.



□ Step 5

Secure the tail wheel into position using the 5/64-inch wheel collar and the 4-40 setscrew.

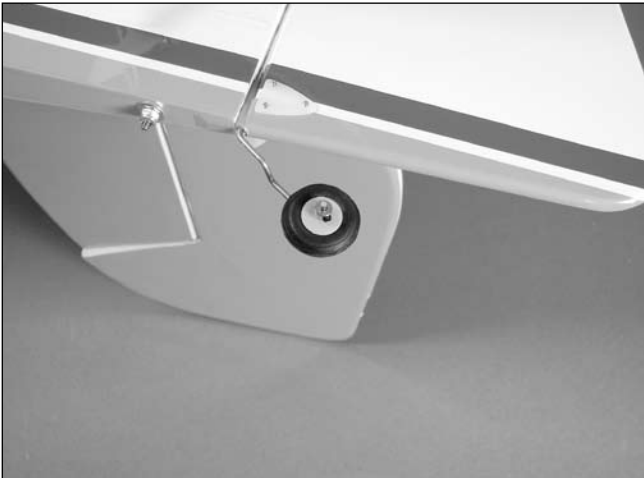

Note: Use threadlock on the setscrew to prevent it from vibrating loose in flight.

□ □ Step 6

Attach an 18-inch (458mm) servo extension to the rudder servo. Secure the extension using a commercially available connector, heat shrink tubing or string so it will not unplug inside the fuselage.

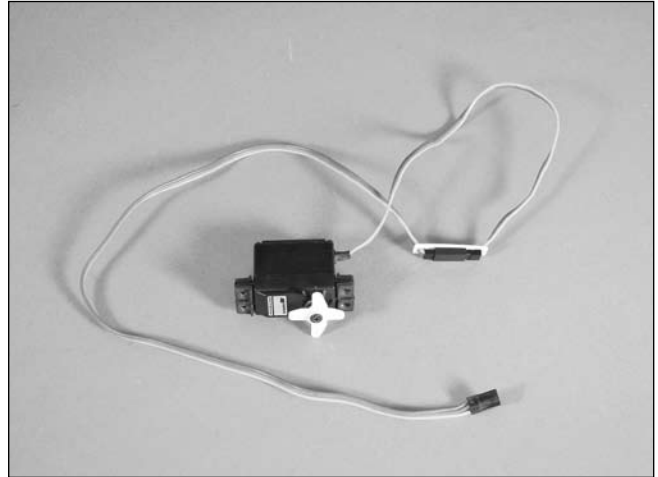

□ □ Step 7

Center the servo using the radio and install a long servo arm onto the servo. Use the photo to determine which arm to trim off, as it will hit the elevator if left in place. Mount the rudder servo into the fuselage using the same procedure as the aileron servo.

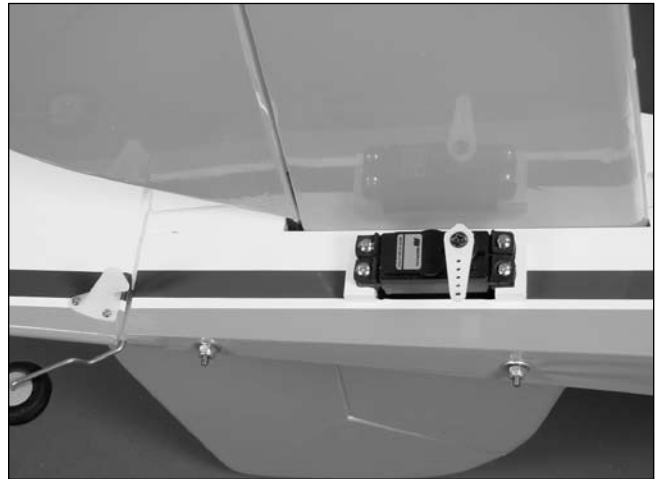

Section 2: Landing Gear and Tail Installation

□ □ Step 8

Install the pre-assembled 4 1/2-inch (114mm) rudder linkage. With the radio on, adjust the length of the linkage so the rudder is centered.

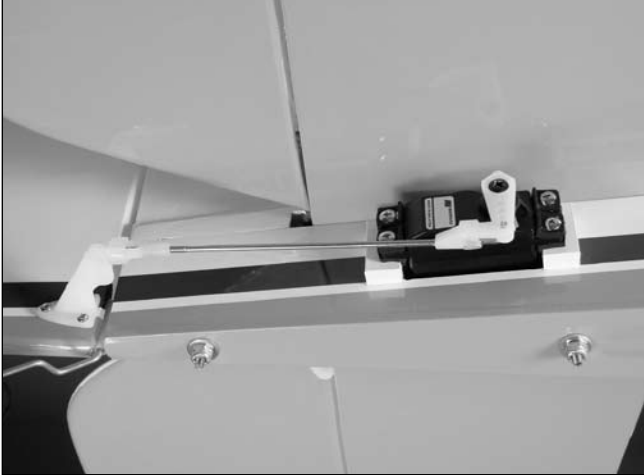

□ Step 9

Repeat Steps 6 through 8 to install the elevator servo and linkage.

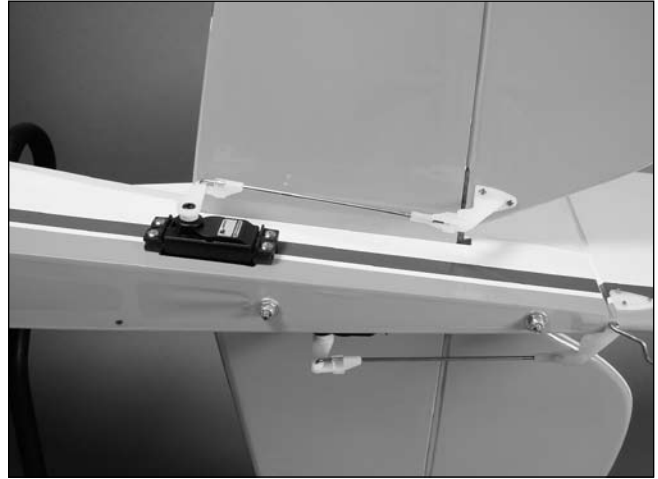

Section 3A: Two-Stroke Engine Installation

Required Parts

- Fuselage
- #6 washer (4)
- 6-32 locknut (4)
- 4-40 x 1/2-inch socket head screw
- 6-32 x 1-inch machine screw (8)
- 15-inch (380mm) throttle pushrod
- 2 1/2-inch (64mm) spinner w/hardware
- Pushrod connector backplate
- 3mm x 5mm machine screw
- Plywood radio tray (glow)
- Engine mount (2)
- Pushrod connector
- #4 washer

Required Tools and Adhesives

- Servo w/hardware
- Drill
- Hex wrench: 3/32-inch
- Drill bit: 1/16-inch (1.5mm), 5/64-inch (2mm), 9/64-inch (4mm)
- Ruler
- Phillips screwdriver
- Hobby knife

□ Step 1

Mount the engine mount onto the firewall using four 6-32 x 1-inch screws.



Note: Use the vertical holes for mounting the engine mount.

Note: Use threadlock on the screws to prevent them from vibrating loose in flight.

Section 3A: Two-Stroke Engine Installation

□ Step 2

Position the engine on the engine mount so the drive washer is 4 inches (102mm) ahead of the firewall. Mark the location of the engine mounting bolts using a felt-tipped pen. Use a 9/64-inch (4mm) drill bit to drill the holes in the engine mount.



Hint: Use a drill press to get the holes in the mount perpendicular to the mount.

□ Step 3

Mount the engine to the mount using four 6-32 x 1-inch machine screws, four #6 washers and four 6-32 locknuts.



□ Step 4

Slide the 15-inch (380mm) throttle pushrod into the pushrod tube and attach the clevis to the carburetor arm.

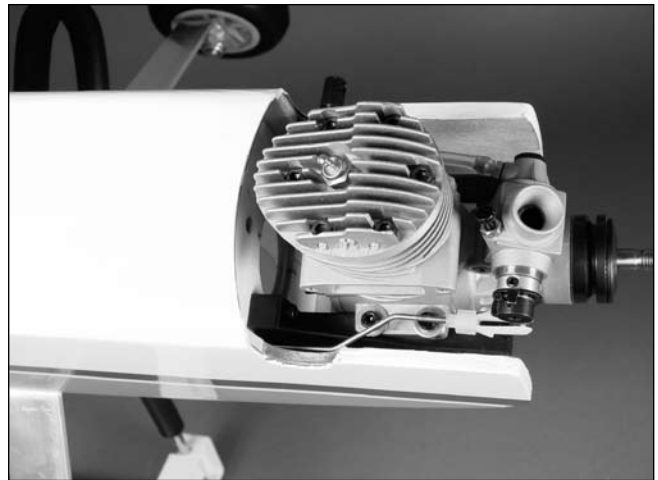

□ Step 5

Install the muffler onto your engine using the instructions provided with the engine as a guide.



Section 3A: Two-Stroke Engine Installation

□ Step 6

Install the propeller and spinner onto the engine. Consult the instructions provided with your engine for further details.



□ Step 7

Remove the access hatch from the bottom of the fuselage.



□ Step 8

Install the throttle servo into the fuselage. Turn on the radio system and center the throttle stick and trim. Slide the pushrod into the brass connector. Position the servo horn onto the servo so the horn is perpendicular to the servo centerline.

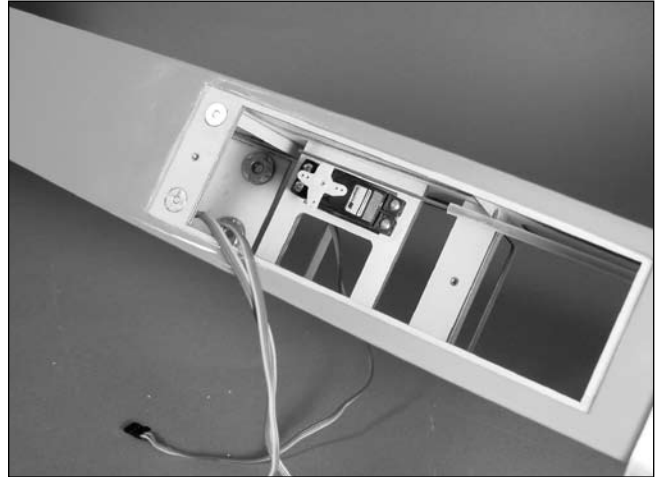

□ Step 9

Remove the servo horn and attach the pushrod connector to the throttle servo arm using the connector backplate. You will need to enlarge the hole in the servo arm using a 5/64-inch (2mm) drill bit.

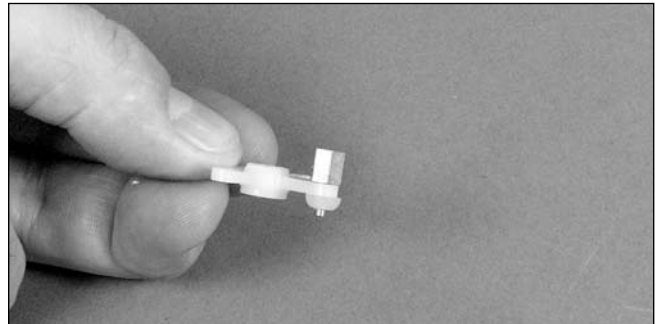

Section 3A: Two-Stroke Engine Installation

□ Step 10

Use the radio to move the throttle to the low setting using the stick and trim. Move the pushrod so the carburetor is closed. Secure the pushrod wire using a 3mm x 5mm machine screw.

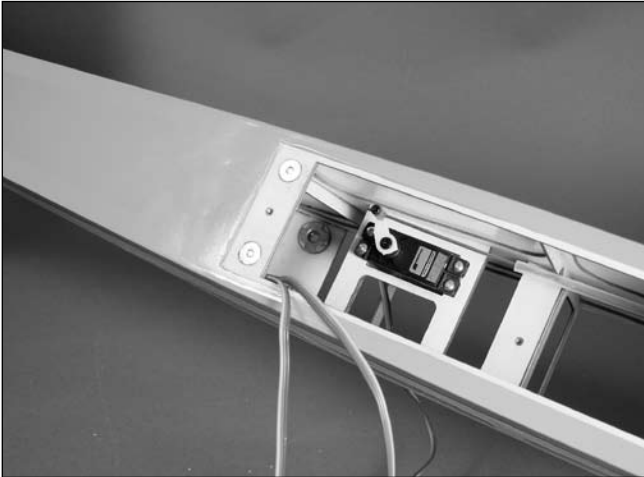

□ Step 11

Check that the throttle operates from the radio without binding at low and high throttle. Use the ATV setting of the radio or change the position of the clevis at the carburetor or the pushrod connector at the servo to eliminate any binding.

□ Step 12

Place the tank inside the fuselage with the vent towards the top of the fuselage. Use the rubber bands to hold the fuel tank in position inside the fuselage.



□ Step 13

Attach the lines from the fuel tank to the engine. The green line will attach to the fuel inlet, and the red to the muffler pressure.



□ Step 14

Use a 4-40 x 1/2-inch socket head screw to secure the radio tray in the fuselage. Two trays have been supplied with your Tango 40, so use the one with the notch at the front that will hold the fuel tank in position.

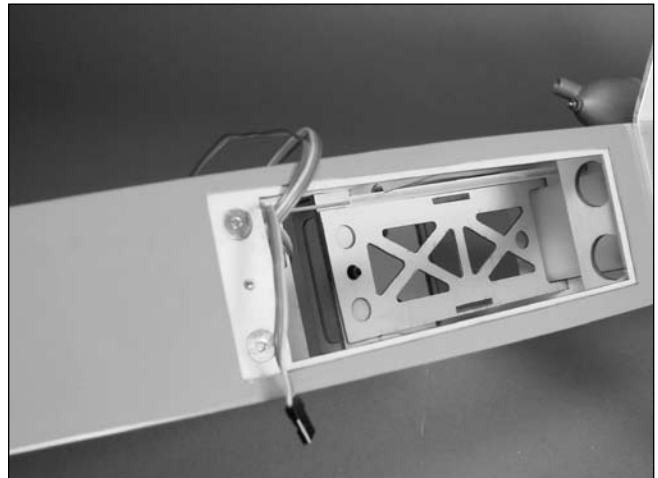

Section 3B: Electric Motor Installation

Required Parts

- Fuselage
- Hook and loop strap
- Plywood battery tray (electric)
- 6-32 x 2 1/2-inch machine screw (4)
- 4-40 x 1/2-inch socket head screw
- 1-inch (25mm) aluminum motor spacer (4)
- 2 1/2-inch (64mm) spinner w/hardware
- #4 washer

Required Tools and Adhesives

- Phillips screwdriver
- Hobby knife
- Solder
- Hex wrench: 3/32-inch
- Female Deans connector w/wire
- Male Deans connector
- Threadlock
- Soldering iron
- Drill

Step 1

Attach the X-mount to the back of the motor using the hardware provided with the motor. Remember to put a drop of threadlock on each of the screws to prevent them from vibrating loose.



Step 2

Attach the motor to the firewall using the four 1-inch (25mm) aluminum motor spacers and four 6-32 x 1 1/2-inch machine screws.

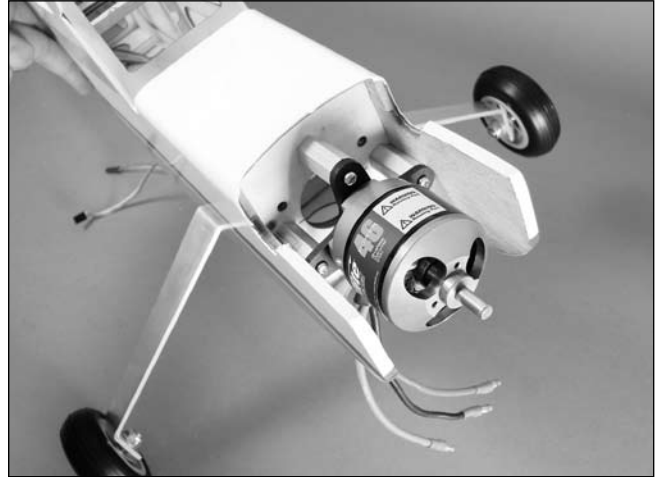

Note: Use threadlock on the screws to prevent them from vibrating loose in flight.

Section 3B: Electric Motor Installation

Step 4

Solder the appropriate connectors onto the speed control.

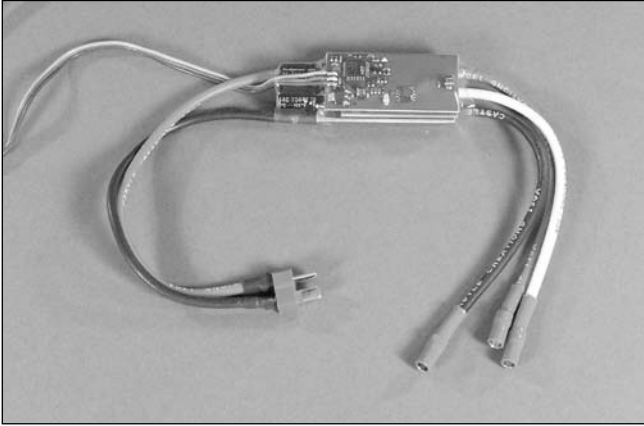

Step 5

Secure the speed control to the plywood battery tray as shown. Make sure it will not move when installed in the fuselage.

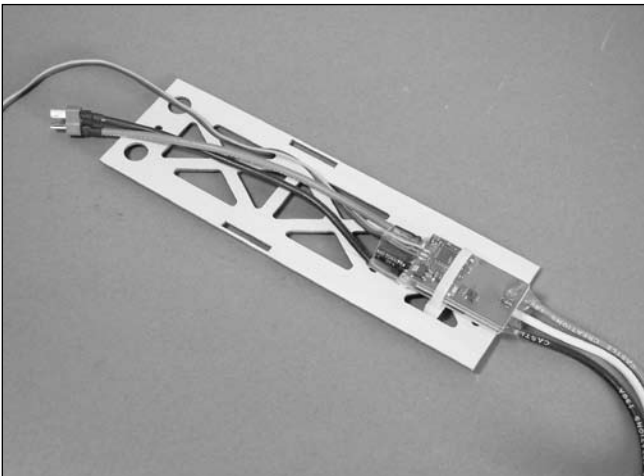

Step 6

Slide the plywood battery tray into the fuselage. Secure the tray using a 4-40 x 1/2-inch socket head screw and #4 washer.

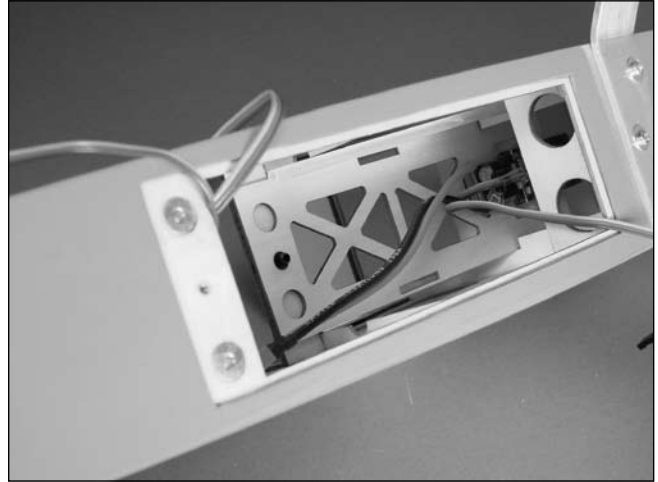

Step 7

Connect the leads from the motor to the speed control. Secure the wires so they will not interfere with the operation of the motor.

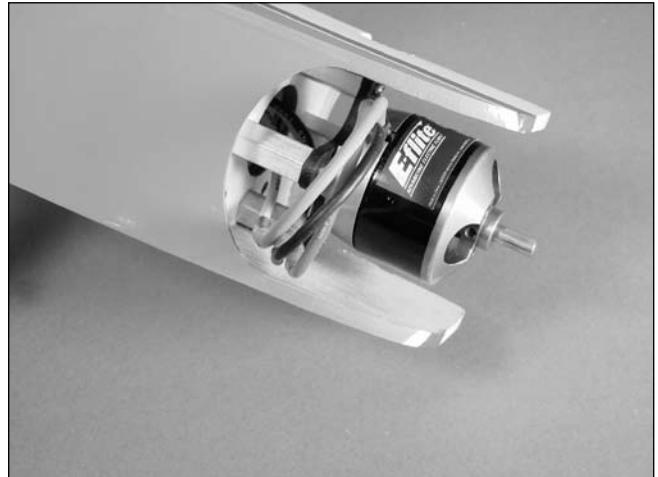

Section 3B: Electric Motor Installation

□ Step 8

Remove the covering from the bottom of the fuselage to allow for cooling air through the fuselage.

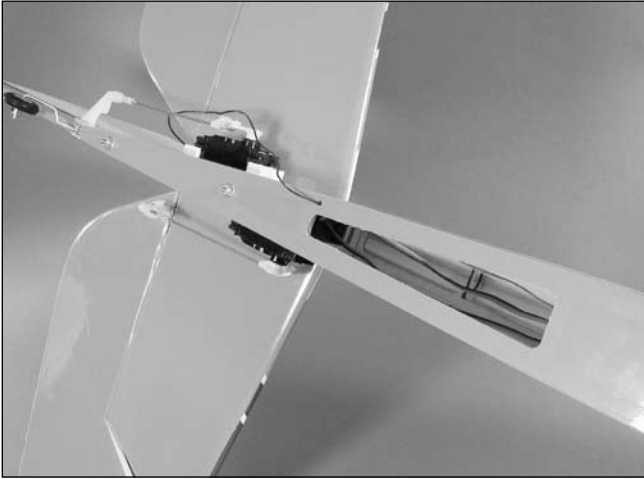

□ Step 9

Plug the motor into the speed control. Secure the batteries using the hook and loop strap. Plug the speed control into the receiver. Mount the speed control inside the fuselage so it will not interfere with the installation and removal of the batteries.

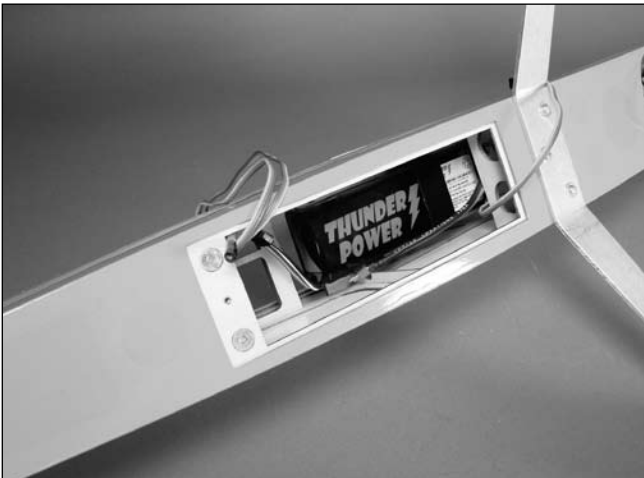

Note: Apply a piece of hook and loop (not included) on the batteries and battery tray if you find the batteries slide forward or aft.

□ Step 10

Turn on the radio system. Plug the batteries and speed control together. Use the throttle on the transmitter to check that everything is working correctly. Check that the motor is rotating counterclockwise. If not, follow the directions included with the speed control to correct the situation.

Note: Always check that the motor will not interfere with anything on your workbench.

Never operate the motor at full throttle without a load. Simply use this to check the rotation of the motor before installing the propeller.

□ Step 11

Install the propeller and spinner using the instructions included with your particular motor.



Section 4: Final Assembly

Required Parts

- Fuselage
- Canopy
- 1/4-20 x 2-inch nylon bolt (2)
- Wing
- Hook and loop strap

Required Tools and Adhesives

- Canopy glue
- Masking tape
- Hobby knife
- Receiver battery
- Flat screwdriver
- 1/4-inch foam
- Receiver
- Switch harness

□ Step 1

Wrap the receiver and receiver battery in 1/4-inch foam to protect them from vibration.

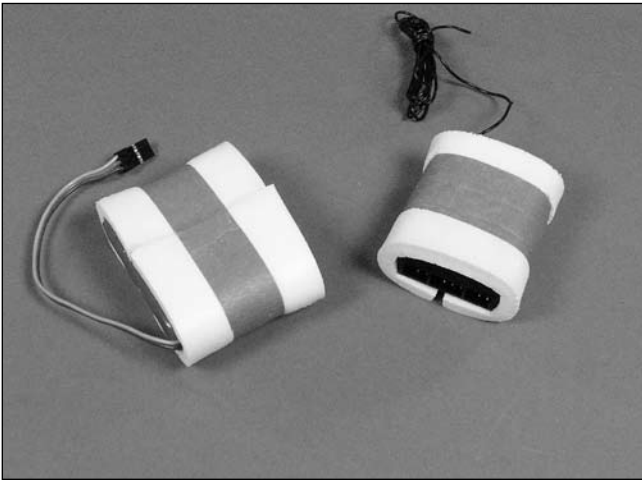

□ Step 2

Plug the throttle, elevator and rudder servo leads, as well as the switch harness, into the receiver. Route the receiver antenna to the rear of the fuselage. A tube has been pre-installed for routing the receiver antenna wire.



□ Step 3

Place the receiver (both electric and glow) into the fuselage on the top of the plywood tray. Use a hook and loop strap to secure the battery to the tray as shown.

Note: When using an electric motor and a receiver pack, place the pack underneath the receiver to provide more room for the motor batteries.

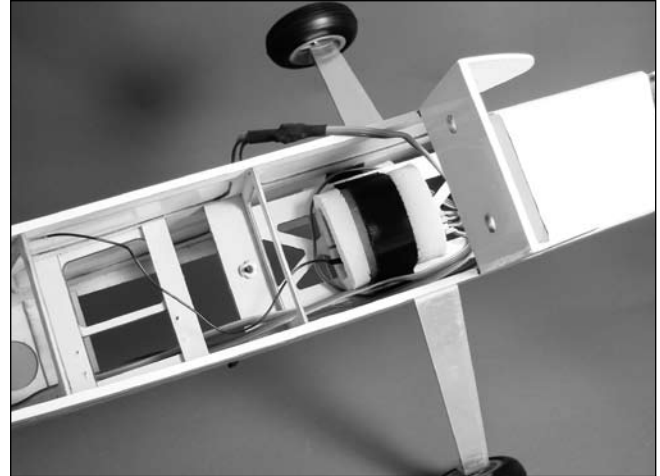

Note: In glow applications, the receiver battery is placed on the bottom side of the plywood tray, and the strap will go around both the receiver and receiver battery.



□ Step 4

Mount the switch harness in the side of the fuselage. The switch should be on the opposite side of the muffler when using a glow engine.

Section 4: Final Assembly

Step 5 (Glow)

Place the hatch back into position on the bottom of the fuselage. Use a 4-40 x 1/2-inch socket head screw and #4 washer to secure the hatch in position.



Note: Use a small 1/4-inch (4mm) piece of fuel tubing slide onto the screw before installation to keep it from vibrating loose in flight.

Step 5 (Electric)

Use a hobby knife to remove the covering from the small hole near the magnets in the hatch. This is so you can easily remove the hatch. Place the hatch into position on the bottom of the fuselage.

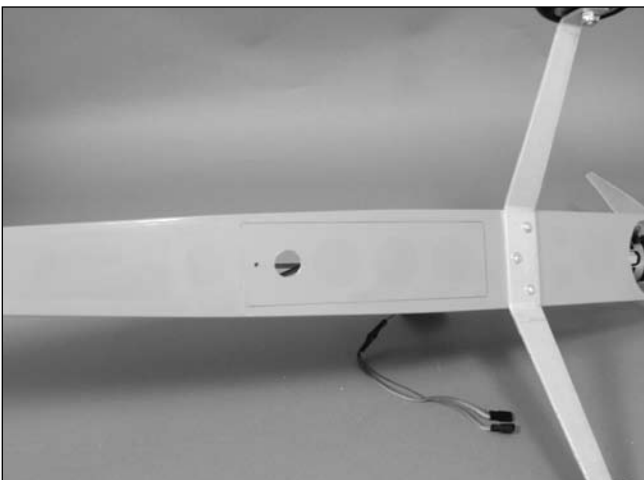

Step 6

Use canopy glue to secure the canopy to the fuselage. Use masking tape to hold the canopy in position until the glue fully cures.

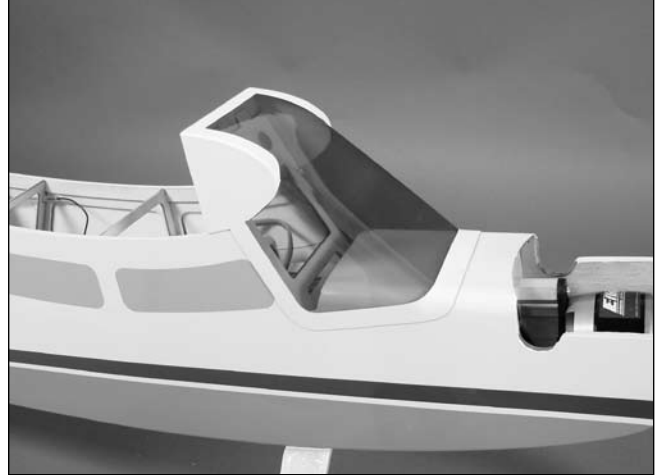

Step 7

Attach the wing to the fuselage using two 1/4-20 x 2-inch nylon bolts.



Control Throws

The amount of control throw should be adjusted as closely as possible using mechanical means, rather than making large changes electronically at the radio. By moving the position of the clevis at the control horn toward the outermost hole, you will decrease the amount of control throw of the control surface. Moving it toward the control surface will increase the amount of throw. Moving the pushrod wire at the servo arm will have the opposite effect: Moving it closer to center will decrease throw, and away from center will increase throw. Work with a combination of the two to achieve the closest or exact control throws listed.

Aileron Low Rate 1 1/2-inch (38mm) up/down
Aileron High Rate 2 1/2-inch (63mm) up/down

Note: Aileron throw is measured at the inboard trailing edge of the aileron.

Elevator Low Rate 1 1/4-inch (32mm) up/down
Elevator High Rate 2 1/2-inch (63mm) up/down

Note: Elevator throw is measured at the inboard trailing edge of the elevator.

Rudder Low Rate 2-inch (51mm) right/left
Rudder High Rate 2 3/4-inch (70mm) right/left

Note: Rudder throw is measured at the bottom of the rudder.

Once the control throws have been set, slide the clevis retainers over the clevis to prevent them from opening during flight.



Recommended Center of Gravity (CG)

An important part of preparing the aircraft for flight is properly balancing the model. This is especially important when various engines are mounted.

Caution: Do not inadvertently skip this step!

The recommended Center of Gravity (CG) location for the Tango 40 is 4- to 5-inches (102–127mm) behind the leading edge of the wing against the fuselage. Mark the location of the CG on the bottom of the wing as shown. Turn the airframe upright to balance. The Tango 40 must be upright when measuring the CG or it will not balance correctly. If necessary, move the battery pack or add weight to either the nose or the tail until the correct balance is achieved. Stick-on weights are available at your local hobby store and work well for this purpose.

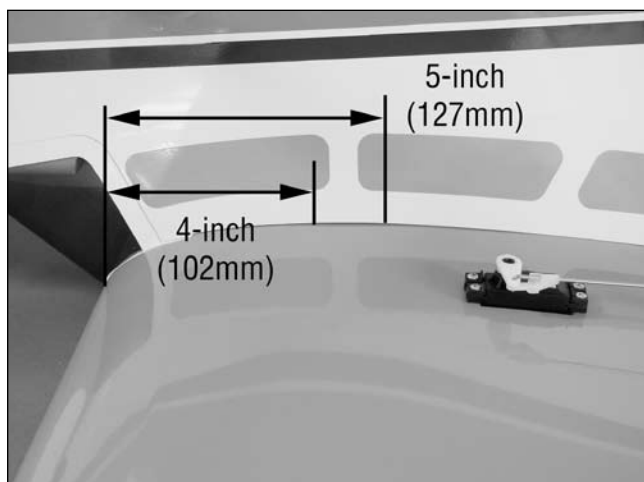

Pre-Flight

Charge both the transmitter and receiver pack for your airplane. Use the recommended charger supplied with your particular radio system, following the instructions provided with the radio. In most cases, the radio should be charged the night before going out flying.

Check the radio installation and make sure all the control surfaces are moving correctly (i.e. the correct direction and with the recommended throws). Test run the engine and make sure it transitions smoothly from idle to full throttle and back. Also ensure the engine is tuned according to the manufacturer's instructions, and it will run consistently and constantly at full throttle when adjusted.

Check all the control horns, servo horns and clevises to make sure they are secure and in good condition. Replace any items that would be considered questionable. Failure of any of these components in flight would mean the loss of your aircraft.

Adjusting the Engine

Step 1

Completely read the instructions included with your engine and follow the recommended break in procedure.

Step 2

At the field, adjust the engine to a slightly rich setting at full throttle and adjust the idle and low-speed needle so that a consistent idle is achieved.

Step 3

Before you fly, be sure that your engine idles reliably, transitions and runs at all throttle settings. Only when this is achieved should any plane be considered ready for flight.

Range Test Your Radio

Range check your radio system before each flying session. This is accomplished by turning on your transmitter with the antenna collapsed. Turn on the radio in your airplane. With your airplane on the ground, you should be able to walk 30 paces away from your airplane and still have complete control of all functions. If not, don't attempt to fly! Have your radio equipment checked out by the manufacturer.

Maintaining Your Tango 40 ARF

The following is a check list that you should follow every time you have completed a flying session with your Tango 40. Doing so will keep your aircraft in the best flying condition.

Clean Up

If you are flying with a glow engine you will want to clean your Tango 40 before loading it into your vehicle to head home. Use a cleaner such as Windex or 409 and a paper towel to wipe down the exterior of your plane, removing the fuel residue. Remember a clean plane will last longer since the fuel won't be allowed to soak into any exposed wood. Even an electric plane may need a little cleaning to remove any grass or bugs from the airframe.

Checking the Propeller

Check to make sure the propeller is tightly secured to the engine. If not, remove the spinner and use a crescent wrench to tighten it back down. If you have had any not-so-great landings, you will want to inspect the propeller for any damage. Small nicks and scratches can quickly become fractures, causing the propeller to be unsafe for flight. Always carry a few spare propellers so a damaged propeller can be replaced at the field, increasing your flying time per trip to the field.

Checking the Clevises

Inspect the aileron, elevator and rudder clevises to make sure they are connected and in good working order. If you find a clevis that is showing signs of wear or is broken, replace it with a new clevis. Also check the nylon connectors at the servo for any wear or damage. If they look worn or in bad shape, replace them as well.

Checking the Control Horns

Inspect the control horns to make sure they have not crushed the wood of the control surface. If so, remove the control horn screws to remove the control horn. Place 2–3 drops of thin CA into each of the screw holes. In addition, use a T-pin to poke small holes in the covering in the area where the control horn mounts, then saturate the area with thin CA. This will harden the wood and give the control horns a solid surface to be mounted to.

Checking the Wheel Collars

Check the setscrews on the main and tail wheel wheel collars to make sure they are not loose. Use a 1.5mm hex wrench to tighten the setscrews. It is suggested if they loosen frequently to remove them, apply threadlock to the setscrews, then secure the wheel collars back into position.

Check the Muffler Bolts

If you are flying with a glow engine, use a 2.5mm hex wrench to make sure the bolts holding the muffler onto the engine are tight and have not vibrated loose during flight.

Check the Engine or Motor Mount Bolts

Remove the spinner and propeller from the engine (or motor) and then remove the cowling from the fuselage. Remove the muffler from the engine (if using a glow engine). Use a Phillips screwdriver and adjustable wrench to make sure the four bolts securing the engine to the mount are tight. Use a Phillips screwdriver to check that the bolts holding the mount to the firewall are tight as well.

Glossary of Terms

- **Ailerons:** Each side of this airplane has a hinged control surface (aileron), located on the trailing edge of the wing. Move the aileron stick on the transmitter left; the left aileron moves up and the right aileron moves down. Moving the left aileron up causes more drag and less lift, causing the left wing to drop down. When the right aileron moves down, more lift is created, causing the right wing to rise. This interaction causes the airplane to turn or roll to the left. Perform the opposite actions, and the airplane will roll to the right.
- **Clevis:** The clevis connects the wire end of the pushrod to the control horn of the control surface. A small clip, the clevis has fine threads so that you can adjust the length of the pushrod.
- **Control Horn:** This arm connects the control surface to the clevis and pushrod.
- **Dihedral:** The degree of angle (V-shaped bend) at which the wings intersect the fuselage is called dihedral. More dihedral gives an airplane more aerodynamic stability. Some sailplanes and trainer planes with large dihedral dispense with ailerons and use only the rudder to control the roll and yaw.
- **Elevator:** The hinged control surface on the back of the stabilizer that moves to control the airplane's pitch axis. Pulling the transmitter's control stick toward the bottom of the transmitter moves the elevator upward, and the airplane begins to climb. Push the control stick forward, and the airplane begins to dive.
- **Fuselage:** The main body of an airplane.
- **Hinge:** Flexible pieces used to connect the control surface to the flying surface. All hinges must be glued properly and securely to prevent the airplane from crashing.
- **Horizontal Stabilizer:** The horizontal flying surface of the tail gives the airplane stability while in flight.
- **Leading Edge:** The front of a flying surface.
- **Main Landing Gear:** The wheel and gear assembly the airplane uses to land. It is attached to the bottom of the fuselage.
- **Pitch Axis:** The horizontal plane on which the airplane's nose is raised or lowered. By moving the elevator, you can raise the airplane's nose above the pitch axis (climb) or lower it below the pitch axis (dive).
- **Pushrod:** The rigid mechanism that transfers movement from the servo to the control surface.
- **Roll Axis:** The horizontal plane on which the airplane's wings are raised or lowered. By adjusting the ailerons, you can drop a wing tip below the roll axis and cause the airplane to bank or roll.
- **Rudder:** The hinged control surface on the vertical stabilizer that controls the airplane's yaw. Moving the rudder to the left causes the airplane to yaw left; moving the rudder to the right causes it to yaw right.
- **Servo:** The servo transforms your transmitter commands into physical adjustments of the airplane.
- **Servo Output Arm:** A removable arm or wheel that connects the servo to the pushrod (also called servo horn).
- **Spinner:** Term describing the nose cone that covers the propeller hub.
- **Threadlock:** A liquid that solidifies; used to prevent screws from loosening due to vibration.
- **Torque Rods:** Inserted into the ailerons, these rigid wire rods run along the wing's trailing edge, then bend downward and connect to the pushrod.
- **Vertical Stabilizer:** The vertical flying surface of the tail gives an airplane stability while in flight.
- **Wheel Collar:** The round retaining piece that anchors wheels in place on the wheel axle.
- **Wing:** The lifting surface of an airplane.
- **Yaw Axis:** The vertical plane through which the airplane's nose rotates as it yaws to the left or to the right. The rudder controls the yaw axis.

2007 Official AMA National Model Aircraft Safety Code

GENERAL

1. A model aircraft shall be defined as a non-human-carrying device capable of sustained flight in the atmosphere. It shall not exceed limitations established in this code and is intended to be used exclusively for recreational or competition activity.
2. The maximum takeoff weight of a model aircraft, including fuel, is 55 pounds, except for those flown under the AMA Experimental Aircraft Rules.
3. I will abide by this Safety Code and all rules established for the flying site I use. I will not willfully fly my model aircraft in a reckless and/or dangerous manner.
4. I will not fly my model aircraft in sanctioned events, air shows, or model demonstrations until it has been proven airworthy.
5. I will not fly my model aircraft higher than approximately 400 feet above ground level, when within three (3) miles of an airport without notifying the airport operator. I will yield the right-of-way and avoid flying in the proximity of full-scale aircraft, utilizing a spotter when appropriate.
6. I will not fly my model aircraft unless it is identified with my name and address, or AMA number, inside or affixed to the outside of the model aircraft. This does not apply to model aircraft flown indoors.
7. I will not operate model aircraft with metal-blade propellers or with gaseous boosts (other than air), nor will I operate model aircraft with fuels containing tetranitromethane or hydrazine.
8. I will not operate model aircraft carrying pyrotechnic devices which explode burn, or propel a projectile of any kind. Exceptions include Free Flight fuses or devices that burn producing smoke and are securely attached to the model aircraft during flight. Rocket motors up to a G-series size may be used, provided they remain firmly attached to the model aircraft during flight. Model rockets may be flown in accordance with the National Model Rocketry Safety Code; however, they may not be launched from model aircraft. Officially designated AMA Air Show Teams (AST) are authorized to use devices and practices as defined within the Air Show Advisory Committee Document.
9. I will not operate my model aircraft while under the influence of alcohol or within eight (8) hours of having consumed alcohol.
10. I will not operate my model aircraft while using any drug which could adversely affect my ability to safely control my model aircraft.
11. Children under six (6) years old are only allowed on a flightline or in a flight area as a pilot or while under flight instruction.
12. When and where required by rule, helmets must be properly worn and fastened. They must be OSHA, DOT, ANSI, SNELL or NOCSAE approved or comply with comparable standards.

2007 Official AMA National Model Aircraft Safety Code

Radio Control

1. All model flying shall be conducted in a manner to avoid over flight of unprotected people.
2. I will have completed a successful radio equipment ground-range check before the first flight of a new or repaired model aircraft.
3. I will not fly my model aircraft in the presence of spectators until I become a proficient flier, unless I am assisted by an experienced pilot.
4. At all flying sites a line must be established, in front of which all flying takes place. Only personnel associated with flying the model aircraft are allowed at or in front of the line. In the case of airshows demonstrations straight line must be established. An area away from the line must be maintained for spectators. Intentional flying behind the line is prohibited.
5. I will operate my model aircraft using only radio-control frequencies currently allowed by the Federal Communications Commission (FCC). Only individuals properly licensed by the FCC are authorized to operate equipment on Amateur Band frequencies.
6. I will not knowingly operate my model aircraft within three (3) miles of any preexisting flying site without a frequency-management agreement. A frequency-management agreement may be an allocation of frequencies for each site, a day-use agreement between sites, or testing which determines that no interference exists. A frequency-management agreement may exist between two or more AMA chartered clubs, AMA clubs and individual AMA members, or individual AMA members. Frequency-management agreements, including an interference test report if the agreement indicates no interference exists, will be signed by all parties and copies provided to AMA Headquarters.
7. With the exception of events flown under official AMA rules, no powered model may be flown outdoors closer than 25 feet to any individual, except for the pilot and located at the flight line.
8. Under no circumstances may a pilot or other person touch a model aircraft in flight while it is still under power, except to divert it from striking an individual.
9. Radio-controlled night flying is limited to low-performance model aircraft (less than 100 mph). The model aircraft must be equipped with a lighting system which clearly defines the aircraft's attitude and direction at all times.
10. The operator of a radio-controlled model aircraft shall control it during the entire flight, maintaining visual contact without enhancement other than by corrective lenses that are prescribed for the pilot. No model aircraft shall be equipped with devices which allow it to be flown to a selected location which is beyond the visual range of the pilot.



Fly First Class™



© 2007 Horizon Hobby, Inc.
4105 Fieldstone Road
Champaign, Illinois 61822
(877) 504-0233
horizonhobby.com