



WACO

OPERATING MANUAL



www.rochobby.com

Please visit our homepage for updated product information

WARNING!

 **WARNING:** Read the ENTIRE instruction manual to become familiar with the features of the product before operating. Failure to operate the product correctly can result in damage to the product, personal property and cause serious injury.

This is a sophisticated hobby product and NOT a toy. It must be operated with caution and common sense and requires some basic mechanical ability. Failure to operate this Product in a safe and responsible manner could result in injury or damage to the product or other property. This product is not intended for use by children without direct adult supervision.

This manual contains instructions for safety, operation and maintenance. It is essential to read and follow all the instructions and warnings in this manual prior to assembly, setup, or use, in order to operate correctly and avoid damage or serious injury.

Safety Precautions and Warnings

As the user of this product, you are solely responsible for operating in a manner that does not endanger yourself and others or result in damage to the product or the property of others. This model is controlled by a radio signal subject to interference from many sources outside your control. This interference can cause momentary loss of control so it is advisable to always keep a safe distance in all directions around your model, as this margin will help avoid collisions or injury.

Age Recommendation: Not for children under 14 years. This is not a toy.

- Never operate your model with low transmitter batteries.
- Always operate your model in an open area away from cars, traffic or people.
- Avoid operating your model in the street where injury or damage can occur.
- Never operate the model in the street or in populated areas for any reason.
- Carefully follow the directions and warnings for this and any optional support equipment (chargers, rechargeable battery packs, etc.) you use.
- Keep all chemicals, small parts and anything electrical out of the reach of children.
- Moisture causes damage to electronics. Avoid water exposure to all equipment not specifically designed and protected for this purpose.
- Never lick or place any portion of your model in your mouth as it could cause serious injury or even death.

ROC HOBBY Friendly Reminder



Thank you for purchasing a ROC HOBBY product. Our goal is to provide high quality products and offer great customer service. If you have any problems with your product or want to offer suggestions for improvements (such as plane design, packaging, building instructions, etc.) please feel free to contact us at info@rochobby.com

Table of contents

Kit contents	1
The spare parts list	1
Spare parts list content	
The illustration of the spare parts	
Kit Inspection	3
Charging the Flight Battery	3
Low Voltage Cutoff	6
Assemble the plane	6
Install the control horn	
Install the lower wing	
Install the main landing gear	
Install the interplane strut	
Mount the top wing	
Arrange the LED wire	
Mount the Horizontal stabilizer	
Install the receiver and battery	
Hook the linkage rod	
Get your model ready to fly	14
Important ESC and plane information	
The transmitter and model setup	
Check the control throws	
Check the motor rotating direction	
Install the propeller	
Install the flapron linkage	
Install the flying wires and pilot	
Check the C.G. (Center of Gravity)	
Before the model flying	20
Find a suitable flying site	
Perform the range check of your plane	
Monitor your flight time	
Flying course	21
Take off	
Flying	
Landing	
Maintenance	
Troubleshooting	22
AMA	23

Kit contents



Kit contents

1. The fuselage assembly (With the motor, the canopy, the electronic parts, ESC)
2. Main wing set (The top wing and the lower wing)
3. Horizontal stabilizer with the elevator
4. Main landing gear set
5. Propeller and spinner
6. Spare parts bag and pilot figure
7. Interplane struts and cabane

The spare parts list

Replacement parts for the ROC **WACO** are available using the order numbers in the Spare parts list that follows. The fastest, most economical service can be provided by your hobby dealer or mail-order company.

Spare parts list content

- KE-101. Fuselage **Yellow/Red** (Bare with all the plastic parts installed)
- KE-102. Top wing **Yellow/Red** (Be painted with all the plastic parts installed)
- KE-103. Lower wing **Yellow/Red**(Be painted with all the plastic parts installed)
- KE-104. Elevator **Yellow/Red**
- KE-105. Cockpit **Yellow/Red**
- KE-106. Cowl **Yellow/Red**
- KE-107. Wind shield **Yellow/Red**
- KE-108. Main landing gear **Yellow/Red**(With the auxiliary stay bar)
- KE-109. Rear landing Gear **Yellow/Red**(With wheel)

- KE-110. Motor Board
- KE-111. Spinner (Propeller holder and spinner)
- KE-112. Propeller (11* 7)
- KE-113. Cabane **Yellow/Red**
- KE-114. Interplane strut **Yellow/Red**
- KE-115. Linkage rod
- KE-116. Motor Shaft
- KE-117. Motor (D3536- KV 850)
- KE-118. 9g Servo (With arm)
- KE-119. ESC (35A / 4A SBEC)
- KE-120. Battery (11.1v, 1800mAh, 25C)
- KE-121. Decal sheet **Yellow/Red**

The illustration of the spare parts



KE 101



KE 102



KE 103



KE 104



KE 105



KE 106



KE 107



KE 108



KE 109



KE 110



KE 111



KE 112

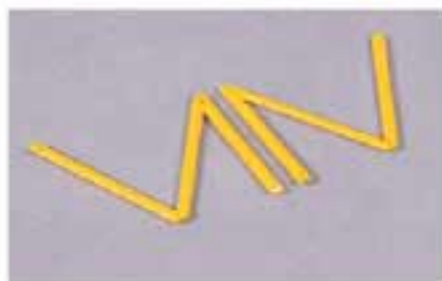

KE 113



KE 114

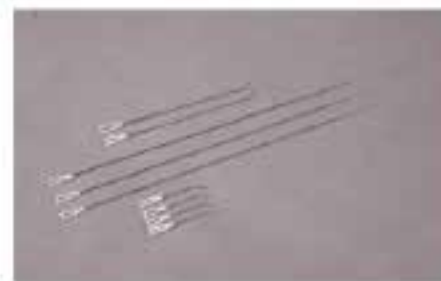

KE 115



KE 116



KE 117



KE 118



KE 119



KE 120

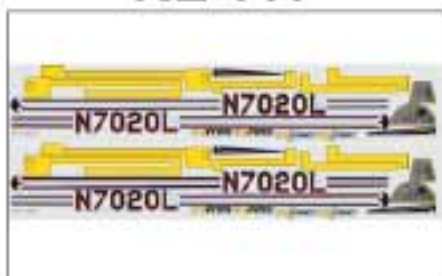

KE 121

Kit inspection

Before starting to build, inspect the parts to make sure they are acceptable quality. If any parts are missing or are not in good shape or acceptable quality, or if you need assistance with setup and assembly, please feel free to contact ROC TEAM. Please write down the name of the parts when you are reporting defective or missing of them.

ROC TEAM Product Support

ADDRESS: **3/F, Building B, 3rd Industry Zone, Matigang, Dalingshan Town, Dongguan City, P.R.C**

Tel: **86-0769-86976658**

Email: **info@rochobby.com**

Web: **www.rochobby.com**

Charging the Flight Battery

The Battery Charger included with your aircraft is designed to safely charge the Li-Po battery, **Caution:** All instructions and warnings must be followed exactly. Mishandling of Li-Po batteries can result in fire, personal injury, or property damage.

Battery warning:

By handling, charging or using the included Li-Po battery you assume all risks associated with lithium batteries.

If at any time the batteries begin to swell, or balloon, discontinue use immediately!

Charging or discharging a swelling or ballooning battery can result in fire.

Always store the batteries at room temperature in a dry area to extend the life of the battery. Always transport or temporarily store the battery in a temperature range of 40-120°F. Do not store battery or model in a car or in direct sunlight. If stored in a hot car, the battery can be damaged or even catch fire.

Never use a Ni-Mh charger. Failure to charge the battery with a compatible charger may cause fire resulting in personal injury and property damage.

Never discharge Li-Po cells to below 3V.

Never leave charging batteries unattended.

Never charge damaged batteries.

Charging the flight battery

RTF kits come with a DC balancing charger. You must charge the battery with a Li-Po specific charger only (such as the included **BC-3S10** DC charger). When charging the battery, make certain the battery is on a heat-resistant surface, charge the battery before assembly of the airplane. Install the fully charged battery to perform control tests and binding.

BC-3S10 Balance Charger

To correctly use the charger, please read the instructions before use.

Charging the Flight Battery

Electrical Parameters

Parameter	Min	Type	Max	Unit
Working Voltage	9	12	16	V
Input Power	15			W
Work Temperature	- 20		45	°C
Store Temperature	- 20		65	°C
Charging Stop Voltage	4 . 19	4 . 20	4 . 21	V
Charging Current			1000	mA
Balancing Current	150		200	mA
Activate Current	80		120	mA

Using Steps:

1. Connect the charger to adapter with enough voltage and wattage, then the Power LED will turn on;
2. Connect 2S/3S battery pack to the corresponding balance port (**Do not connect two battery packs at the same time**), then the Charge LED will flicker (1Hz) and start charging.
3. When the Charge LED stops flickering, charging is complete, and the batteries can be unplugged.

Charging Function Description

1. If all voltage of the installed battery pack is higher than 4.18V, charging will not start and the charge LED will shine.
2. If the voltage of one battery or some batteries is lower than 0.7V, charging will not start. If the voltage of the first battery of a 3S battery pack is lower than 0.7V, the charger will charge the battery pack as if it was a 2S battery pack.
3. If the voltage of one battery or some batteries is lower than 2.8V, the charger will activate the battery pack with a small current. If the voltage can't be increased above 2.8V after half an hour, the charger will judge the battery pack as bad. The charge LED will then flicker rapidly (0.5Hz), and charging will stop.

Self Checking Function

1. Charger will perform a self test before each charge. The charge LED will rapidly flicker (0.5Hz) if the charging function is abnormal;
2. Accuracy checking Function: Connect a fully charged 3S battery pack (all voltage at least 4.2V), the charge LED will flicker twice then shine always. This means that the accuracy is normal.

Charging the Flight Battery

Protection Function

1. Reverse connection protection of input
2. Reverse connection protection of output
3. Short circuit protection of output
4. Over voltage protection of output

Troubleshooting

1. **Power LED does not shine** – Adapter isn't connected correctly. Please check the polarity and reconnect adapter.
2. **Charging abruptly stops and tries to restart constantly during charging** – Output power of the adapter is not sufficient, please replace the adapter.
3. **Charge LED does not shine** – Reconnect the battery pack; Check the voltage of batteries.
4. **Charge LED rapidly flickers** – Battery is bad or charging function is abnormal. Replace battery or contact technical support.

Low voltage cut off (LVC)

When a Li-Po is discharged below 3V per cell, it will not hold a charge. The ESC protects the flight battery from over-discharge using Low Voltage Cutoff. Before the battery charge decreases too much, LVC removes power from motor in two ways: (1) Reduces power - ESC reduces motor power (recommended), (2) Hard cutoff - ESC instantly cuts motor power when the pre-set Low Voltage Protection Threshold value is reached. These settings can be changed using the ESC programming guide (available on-line).

Assemble the plane

Install the control horn

1. The control surface horns for the rudder are include in the bags labeled Rudder. Do not discard them incidently.



2. Attach the rudder control horn on the starboard (Right) of the surface with the horn toward the hinge line.

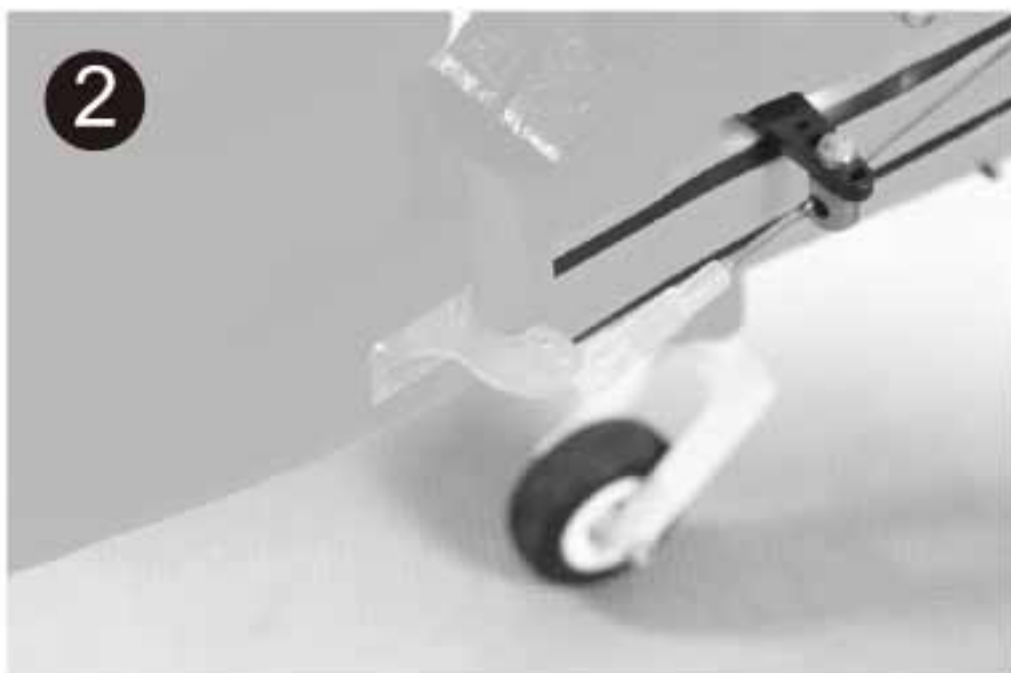

3. Mount the control horn backplate into the opposite side of the surface and secure the horn from the plate side.

Note: The longer screws for secure the horns always located on the leading side of the surface.

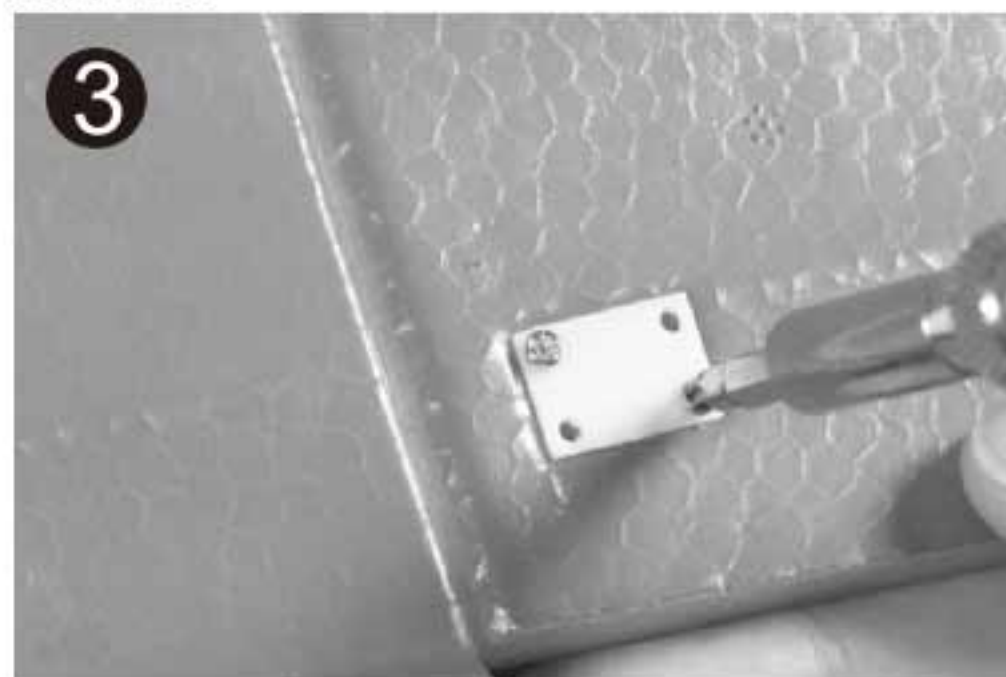

4. Make sure the two pieces of the securing screws are firmly grabbed into the control horn base.



Assemble the plane

5. The aileron control horns are contained in the spare parts bag with the linkage rod.



6. Attach the control horn of the ailerons to the servo side of the lower wing with the horn toward the hinge line.

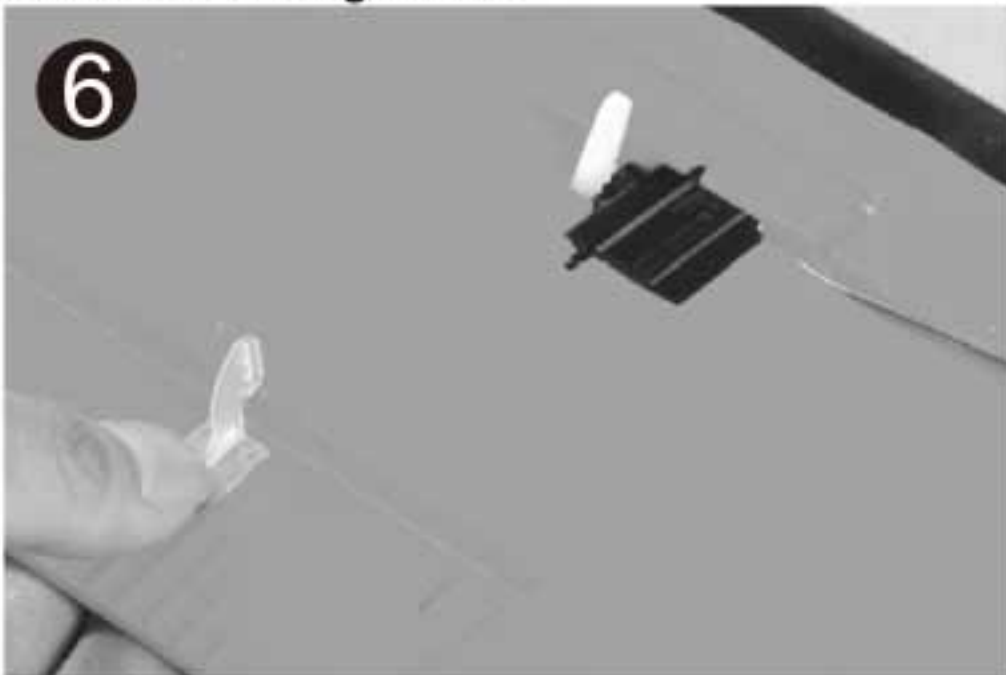

7. Secure the control horns the same with the rudder.

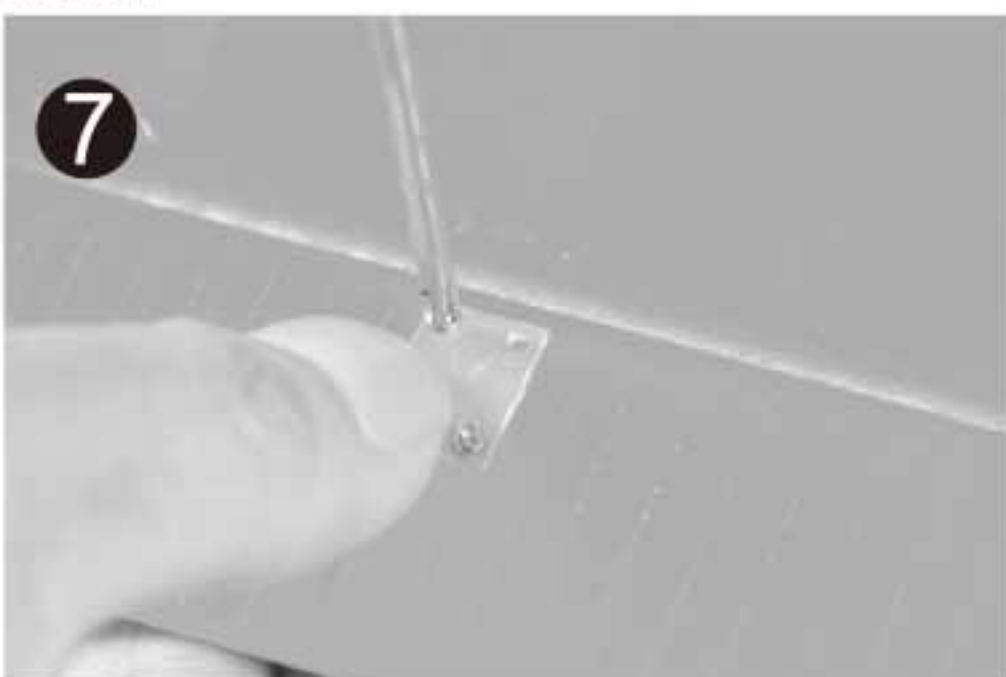

Install the lower wing

1. Insert the Leads of the main wing from the hole on bottom of the wing mounting bay to the cockpit hatch before mounting the lower wing into the bay.

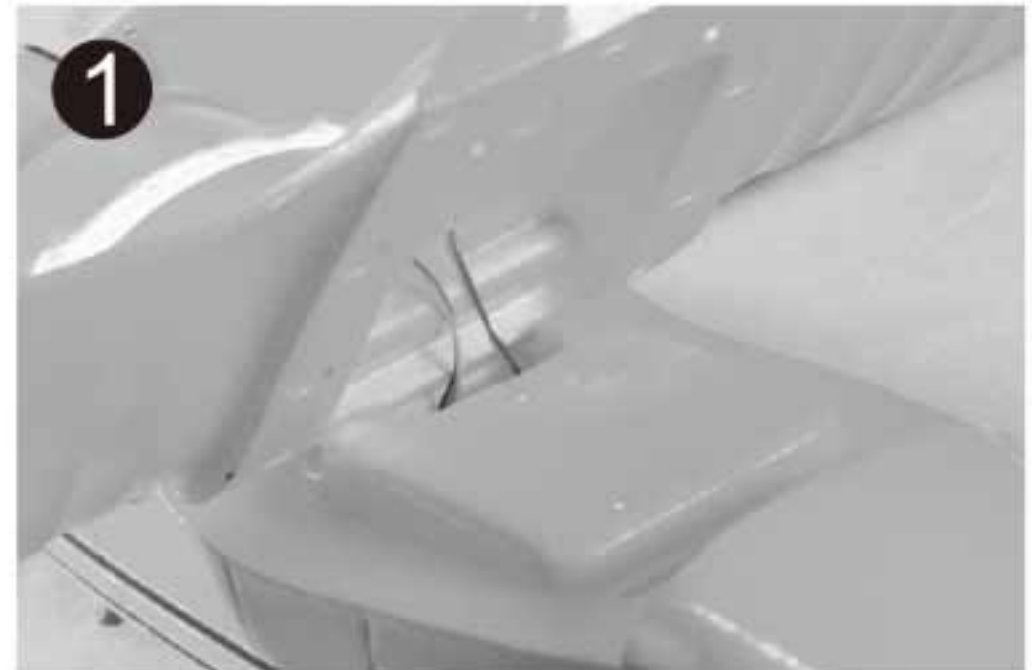

2. Pull the leads from the hatch slightly before fully seat the lower wing into place to avoid any tangling to stop the main wing from fully seat into the bay.



3. Secure the lower wing into place using the provided self tapping screws. (**Screws: A. PA2.6*30 2PCS , B. PA2.6*40 2PCS**)

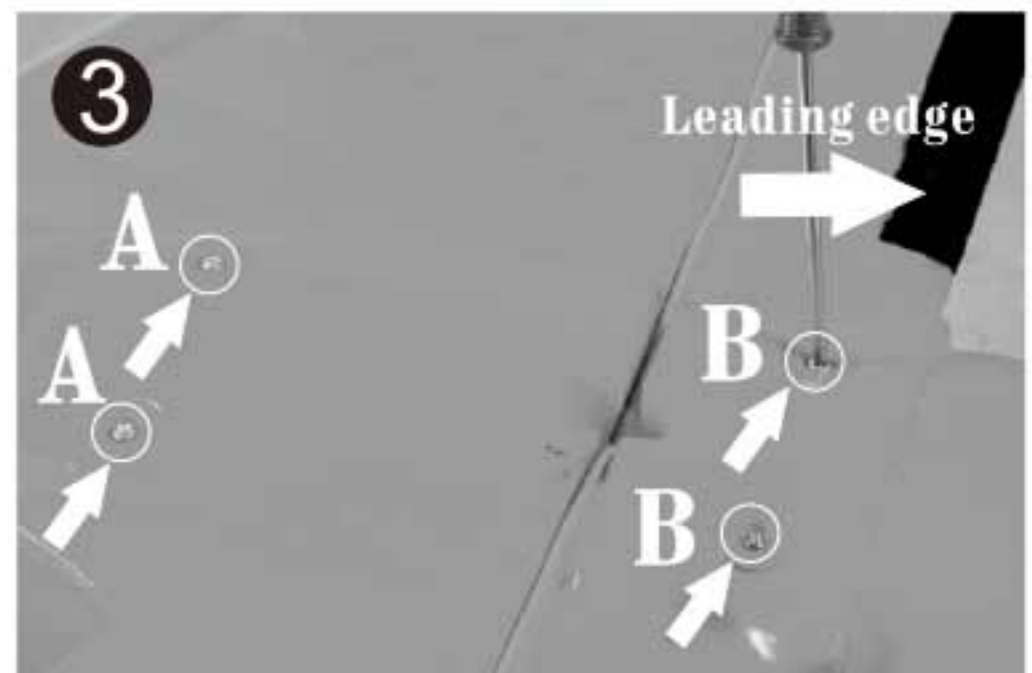

Assemble the plane

Install the main landing gear

1. Insert the landing gear strut into the slot on the landing gear base fully.

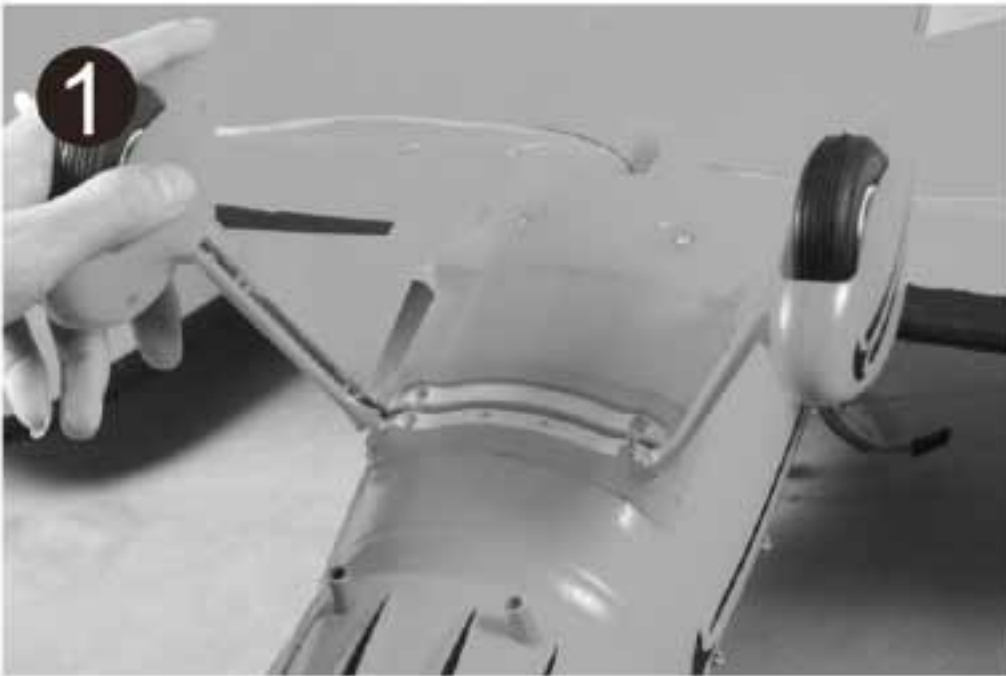

2. Place the landing gear securing fairing plate in place with the right direction.



3. Secure the plate using the provided self tapping screws with the plate.

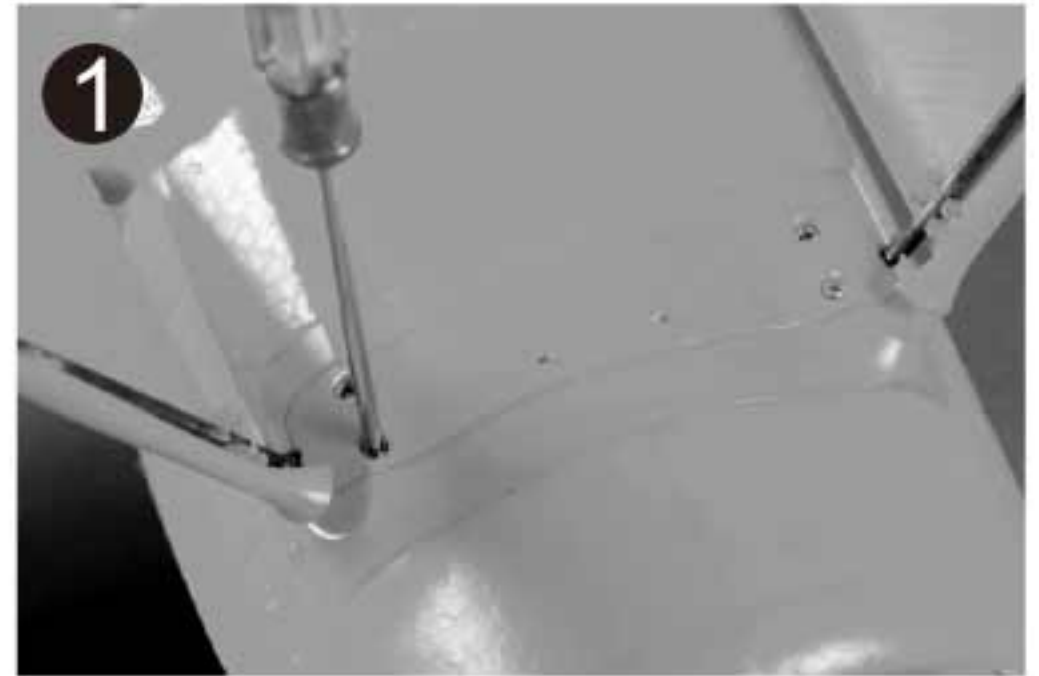

Mount the top wing

1. Test to make sure the port side LED is red and the starboard LED is green.

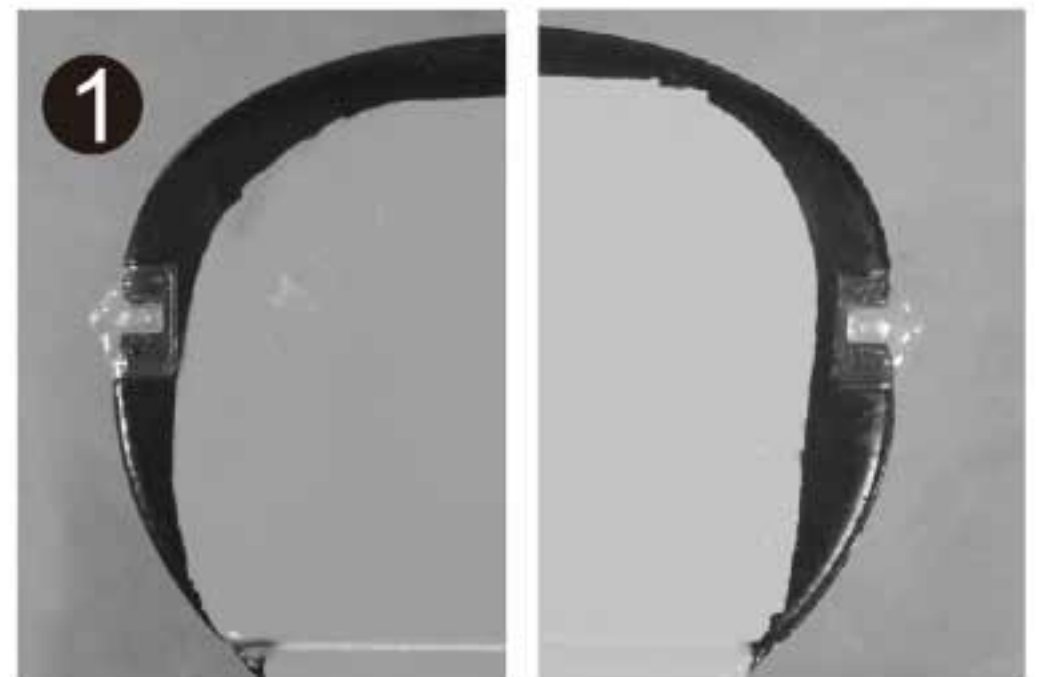

2. Install the interplane strut with a label L to the port side of the top wing.

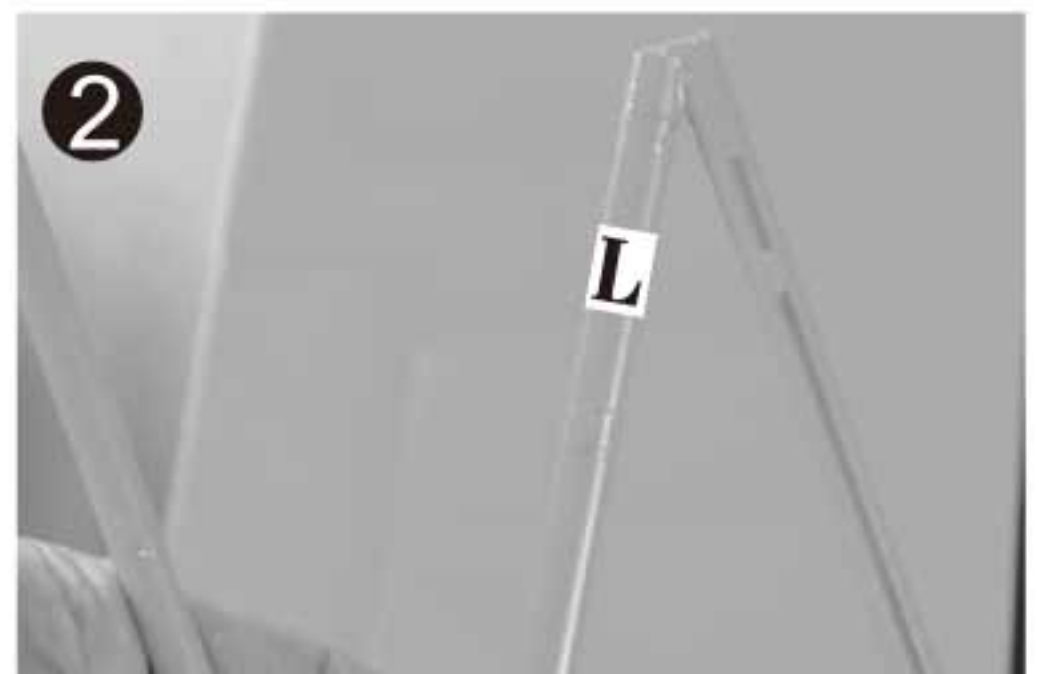

Assemble the plane

3. Secure the strut using two pieces of self tapping screws with the LED wire slot toward the leading edge of the wing. Repeat this step for other strut installation. (Screws: PA 2.0*8 4PCS)



4. Fit the LED wire into the slot on the strut and secure it using the tape. Repeat this step to install the other interplane strut.

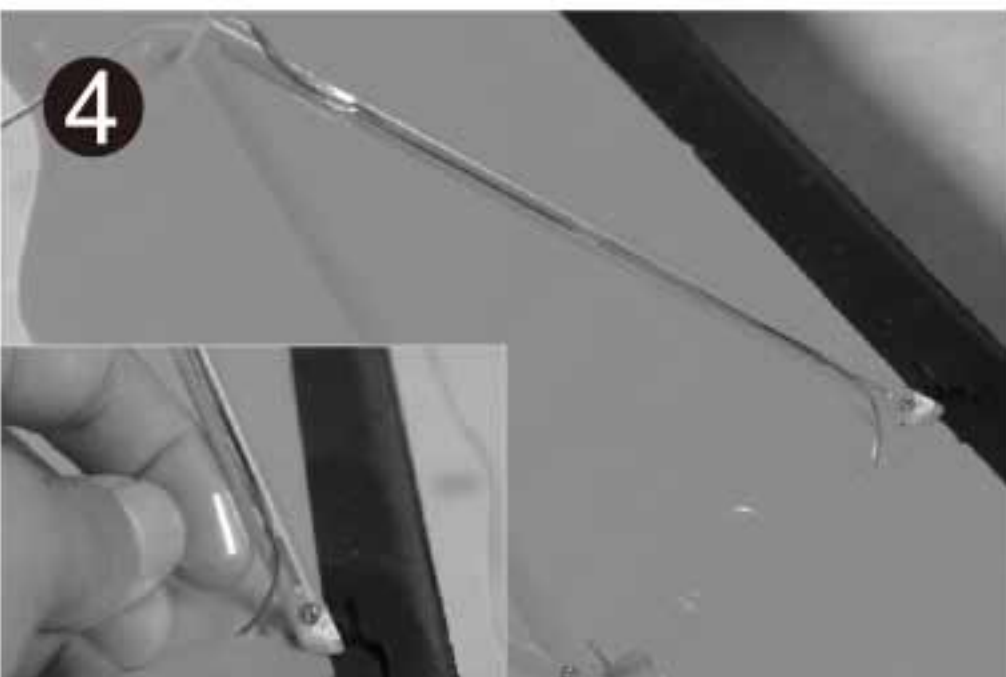

5. Install the wing cabane with a label L to the mounting base on port side of the fuselage.

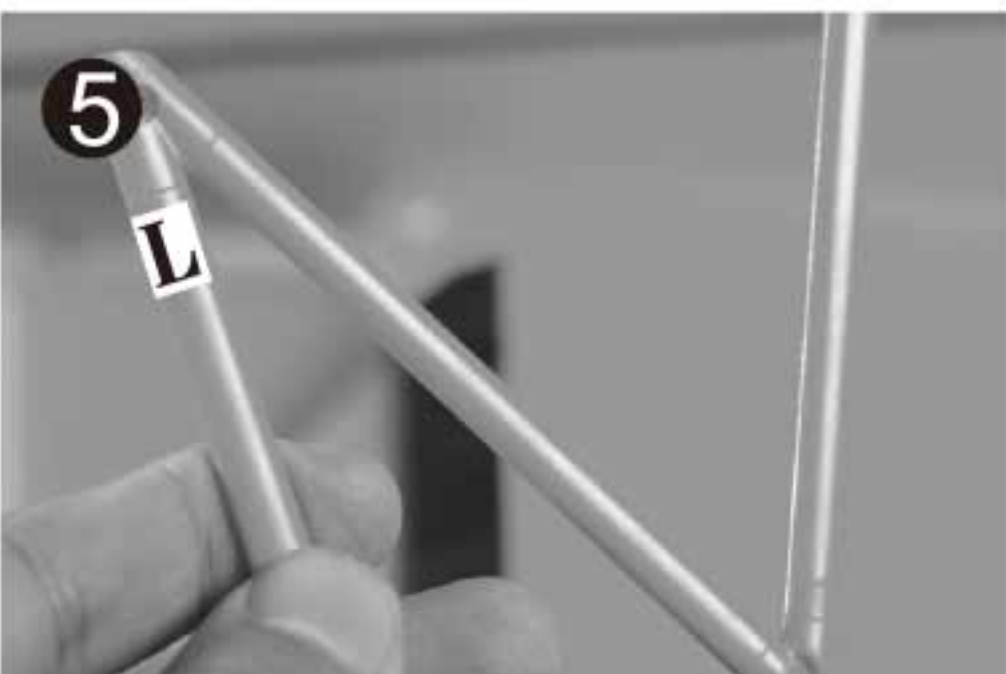

5. Secure the strut using two pieces of self tapping screws as the picture shows, repeat this step for another cabane mounting.



6. Mount the top wing to the cabane properly.



7. Secure the interplane strut to the lower wing top.

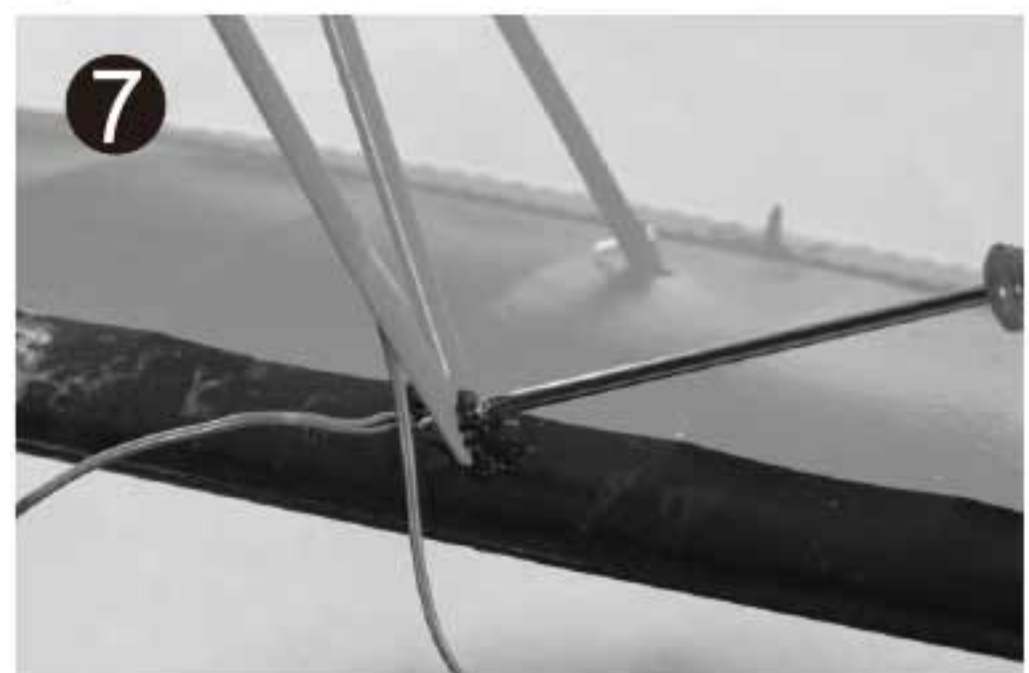

Assemble the plane

8. Turn over the plane so the bottom of the plane face up and secure the top wing to the cabane using self tapping screws. (Screws: PA2.0*8 4PCS)



Arrange the LED wire

1. Thread the leads from the top of the lower wing to the bottom and fix them in the pre-notched slot. Insert the leads from the hole on bottom of the wing to the cockpit hatch.

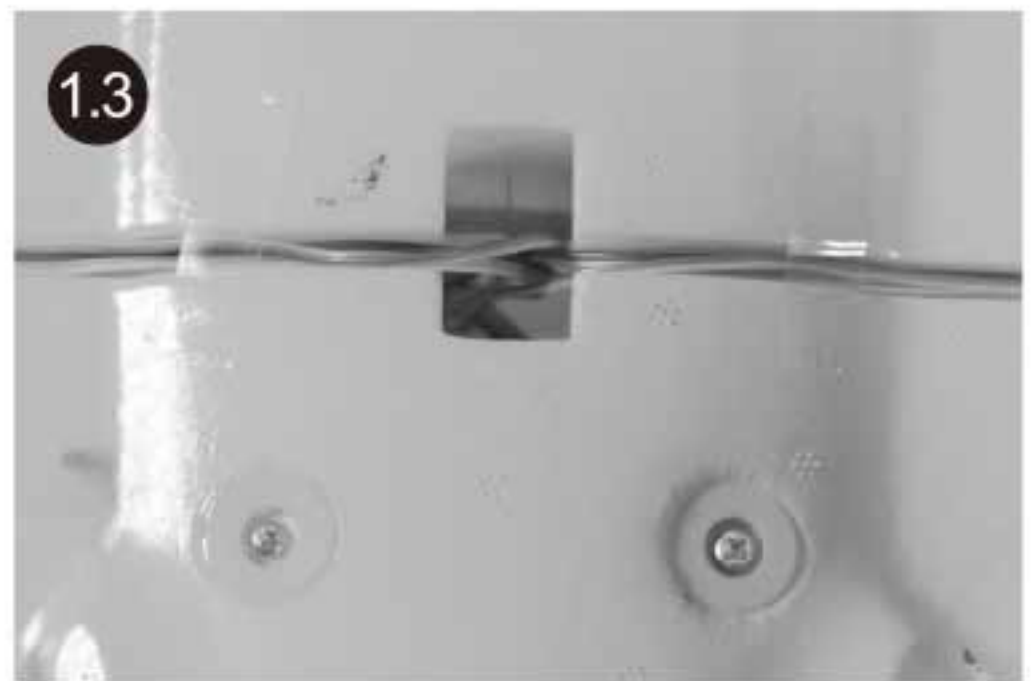
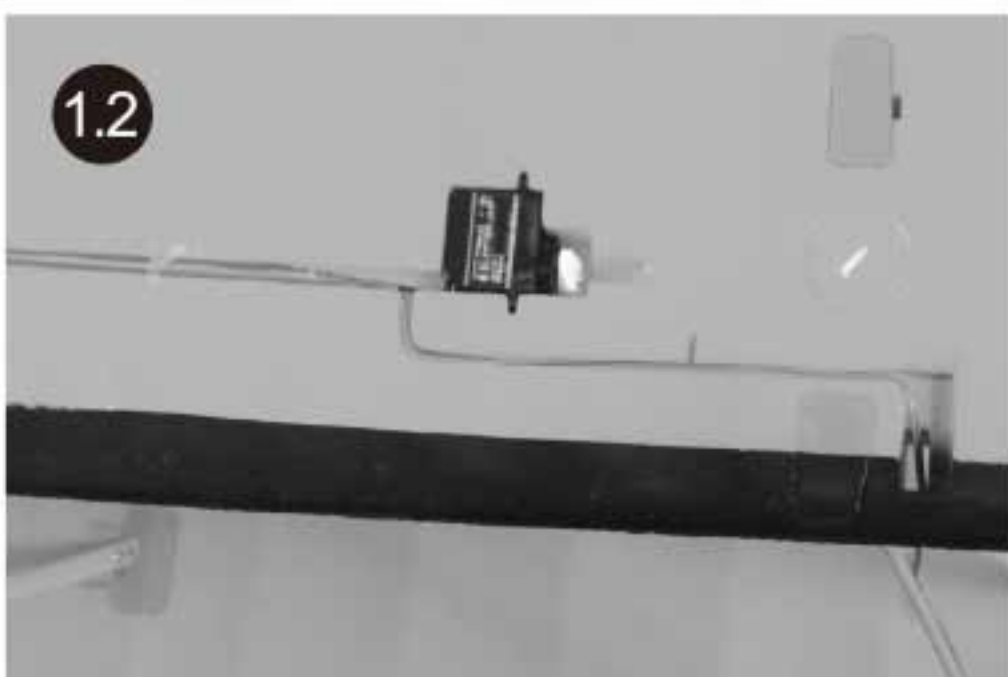
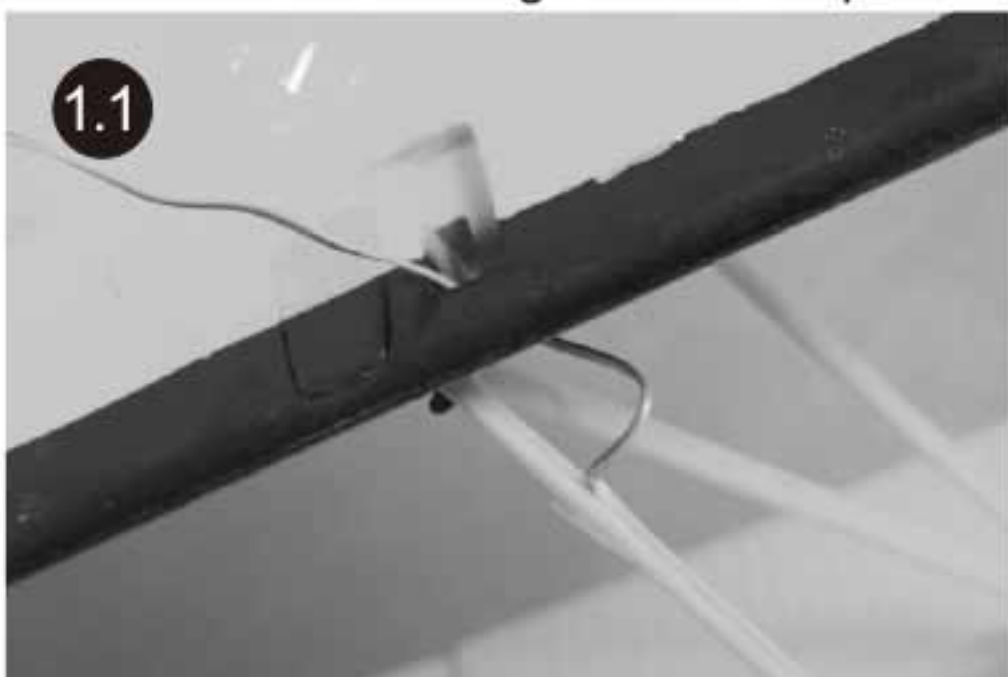

2. Secure the wire into the slot using the in stored wire camouflage tape.



Mount the Horizontal stabilizer

1. Turn over the plane and fully insert the right side (starboard) stabilizer into place.



Assemble the plane

2. Insert the left side stabilizer into place. Make sure the elevator joiners interlock to each other before fully fit the stabilizer into place.

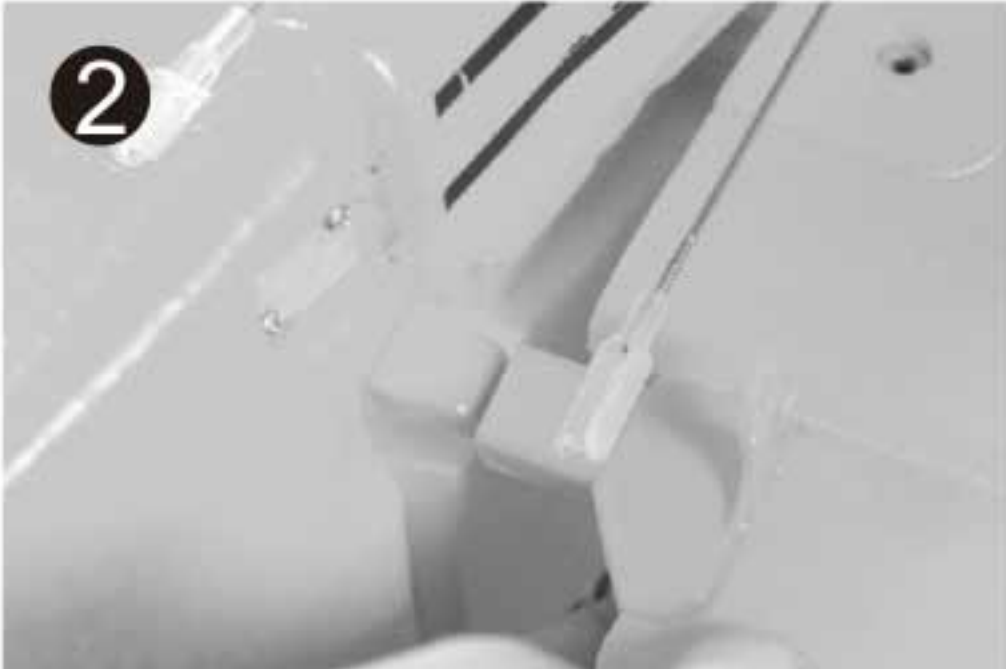

3. Secure the stabilizer into place using the provided screws. (PA2.6*10 2PCS)

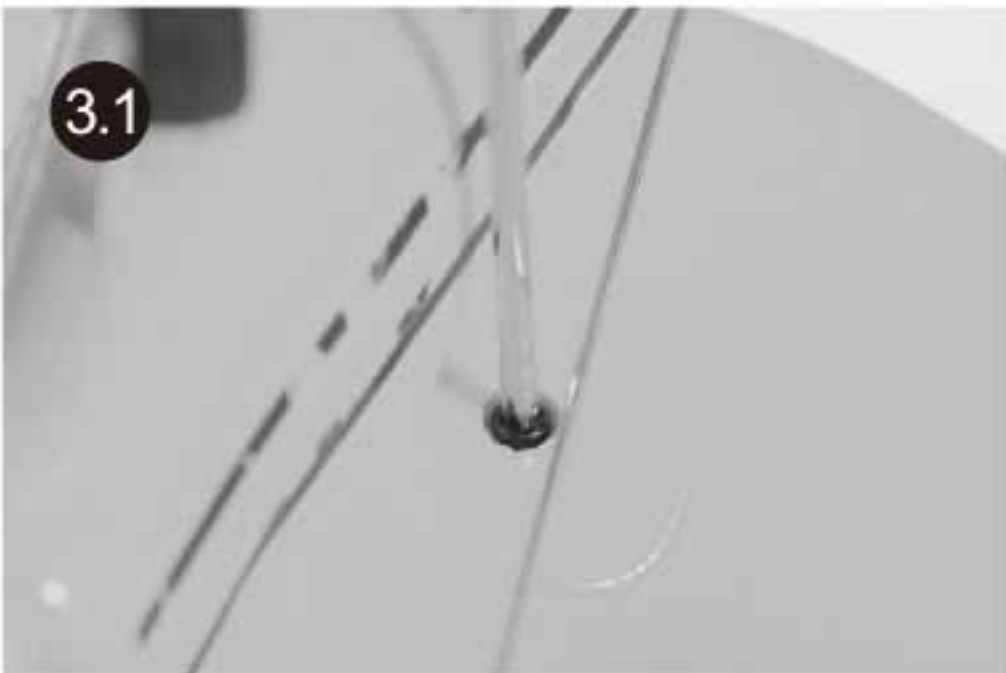

4. Secure the wing joiner from bottom of the elevator. (PA2.0*8 1PCS)

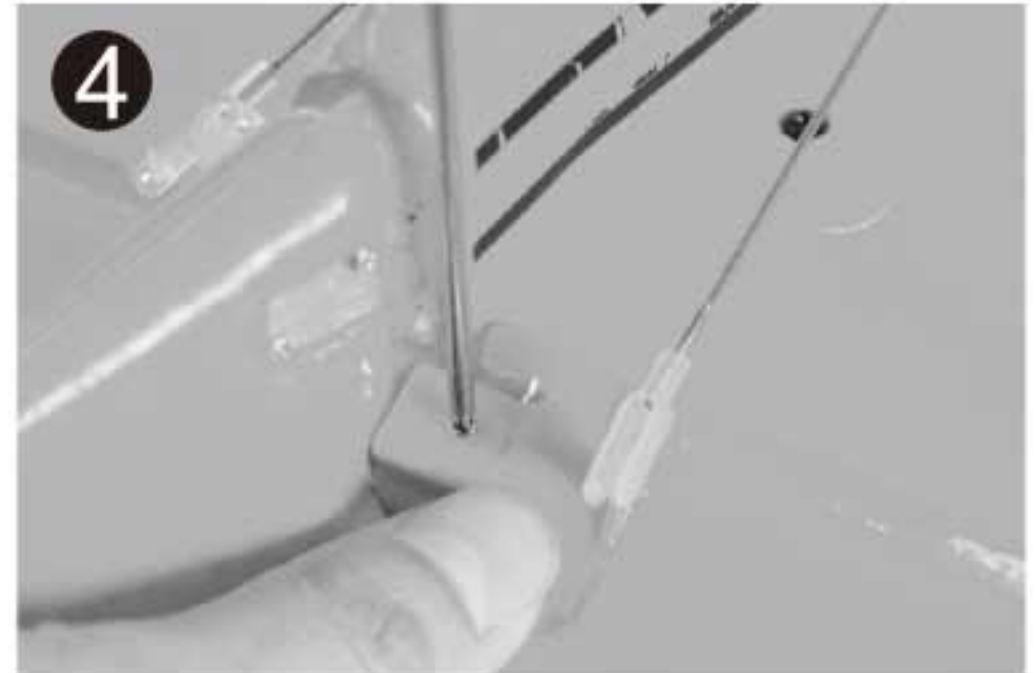

5. Install the main landing gear auxiliary star bar using screws. (PA2.3*5 2PCS)

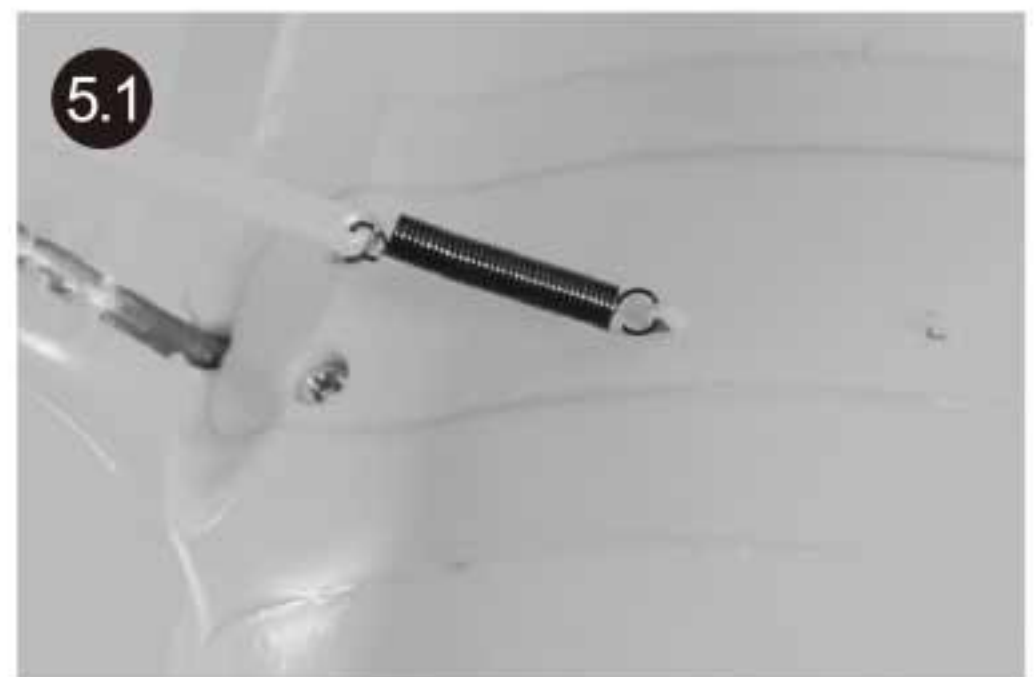

Assemble the plane

Install the receiver and battery

1. Plug the leads to the receiver as the diagram shows.

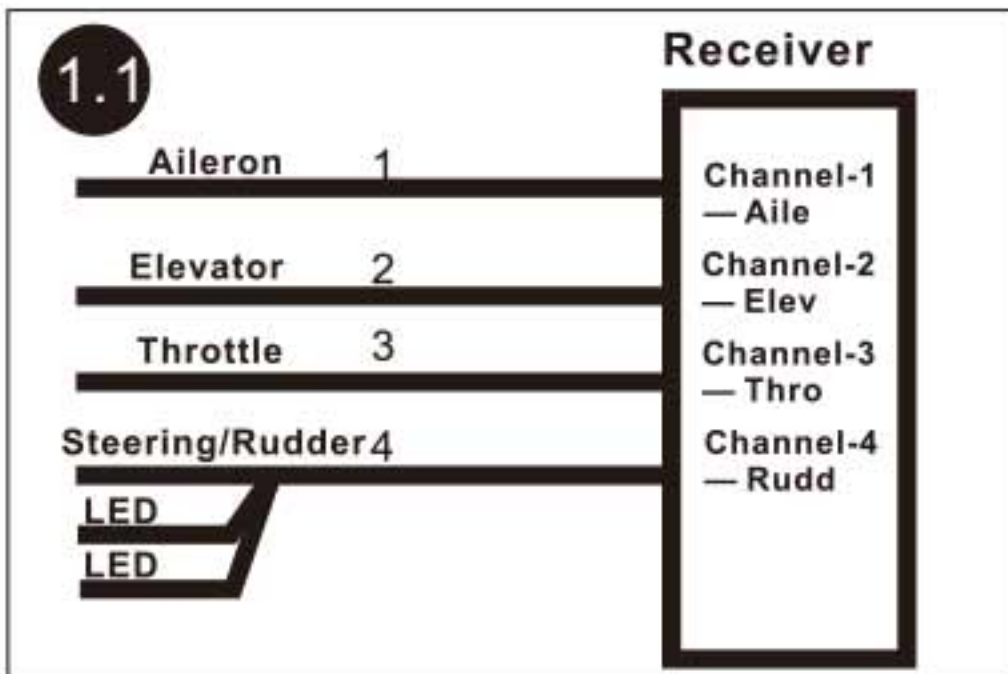

2. Tuck the wire leads into the recessed cavity at the rear end of the servo hatch. Make sure the wires do not interfere with the servo arm moving path.

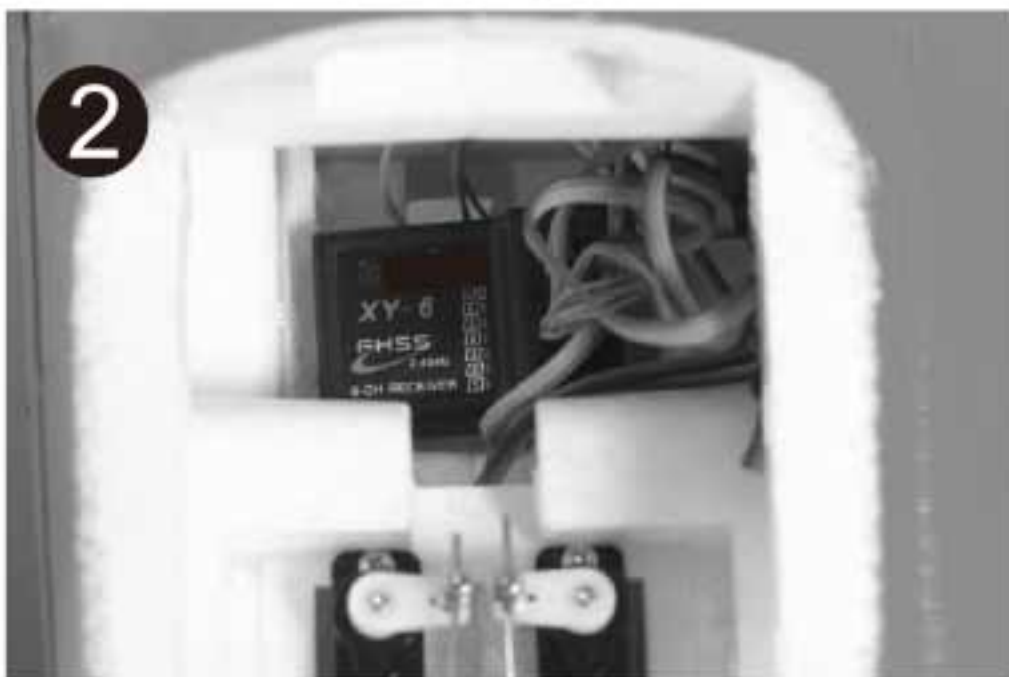

3. Open the battery hatch cover by raise the tape in front, install the battery with the cable toward the rear end of the plane.



Hook the Linkage rod

Before getting started, bind your receiver with your transmitter. Please refer to your **Transmitter Manual** for proper operation. **CAUTION:** To prevent personal injury, **DO NOT** install the propeller assembly onto the motor shaft while testing the control surfaces. **DO NOT** arm the ESC and do not turn on the transmitter until the **Transmitter Manual** instructs you to do so.

1. Set all of the trim or sub trim in neutral position before hook on the linkage rod, then connect the battery to the ESC, adjust the servo arm using a proper screw driver to make sure the arm almost vertical with the servo case.



Assemble the plane

- Put the Z-bend end of the linkage of the ailerons into the desired servo control horn hole. It is a tight fit and should allow the linkage to move just slightly within the hole to avoid binding up.



- Snap the clevis into the surface control horn.



- The provided piece of fuel tubing keeps the clevis closed during flight. Secure all the linkages the same way.

Note: Do not over slide the securing tube or it will impede the movement of the surface control horn.



Tips: Snap in all of the clevis the same and make sure to secure the folk with the rubber ring.

Get your model ready to fly

Important ESC and model information

1. The ESC included with the **WACO** has a safe start. If the motor battery is connected to the ESC and the throttle stick is not in the low throttle or off position, the motor will not start until the throttle stick is moved to the low throttle or off position. Once the throttle stick is moved to the low throttle or off position, the motor will emit a series of beeps. Several beeps with the same tune means the ESC has detected the cells of the battery. The count of the beeps equal the cells of the battery. The motor is now armed and will start when the throttle is moved.
2. The motor and ESC come pre-connected and the motor rotation should be correct. If for any reason the motor is rotating in the wrong direction, simply reverse two of the three motor wires to change the direction of rotation.
3. The motor has an optional brake setting. The ESC comes with the brake switched off and we recommended that the **WACO** be flown with the brake off. However, the brake could be accidentally switched on if the motor battery is connected to the ESC while the throttle stick is set at full throttle. To switch the brake off, move the throttle stick to full throttle and plug in the motor battery. The motor will beep one time. Move the throttle stick to low throttle or the off position. The motor is ready to run and the brake will be switched off.
4. Battery Selection and Installation. We recommend the 11.1V 1800mAh 25C (**150g/5.3oz**) Li-Po battery. If using another battery, the battery must be at least a 11.1V 1800mAh 25C battery. Your battery should be approximately the same capacity, dimension and weight as the 11.1V 1800mAh 25C Li-Po battery to fit in the fuselage without changing the center of gravity significantly.
5. No beeps from the motor, you need to calibrate the throttle or restore the factory setup defaults.

How to calibrate:

1. Power on your Transmitter
2. Set the Throttle stick all the way up to a 100%
3. Power on your aircraft.
4. Wait about 2 seconds in and you will hear 1 beeps, immediately after the first beep, bring your throttle stick all the way down to 0%.
5. You will hear a single initializing beep.
6. Power down you Aircraft then Transmitter.
7. Power on your Transmitter first then the Aircraft and you should be all set.

How to restore: Repeat the **How to calibrate** setting, but the restoring step holds more audible tone accounts, please refers to **ESC manual** to set the ESC, every signal means a tone in the manual. For example, the mark “* __ __*” means a tone. When you here the forth tone in the restore step, bring your throttle stick all the way down to 0%.

Caution: If you try to weld a new connector 3.5 Golden plug, XT 60 or a Dean plug. Please refers to the polarity on your battery and make sure you do not weld the connector pole in reverse, or the short circuit will ruins your battery and the ESC.

5. The specification of the model list as fellow:

Wingspan	: 1030mm /40.6 in
Length	: 810mm /32.3 in
Weight	: 1080g /38.1oz
Battery	: 11.1V 1800mAh Li-Po Battery
ESC	: 35A

Motor	: 3536-850kv
Wing Area	: 30.0dm ²
Wing Load	: 36.0g/dm ²
RC System	: 4 Channel, 4 Servos And 1 Brushless ESC

Get your model ready to fly

The transmitter and model setup

CAUTION: To prevent personal injury, DO NOT install the propeller assembly onto the motor shaft while testing the control surfaces. DO NOT arm the ESC and do not turn on the transmitter until the **Transmitter Manual** instructs you to do so.

Tips: Make sure all control sticks on your radio are in the neutral position (rudder, elevator, ailerons) and the throttle in the OFF position. Make sure both ailerons move up and down (travel) the same amount. This model tracks well when the left and right ailerons travel the same amount in response to the control stick.

1. Move the controls on the transmitter to make sure aircraft control surface move correctly. See diagrams below. Or you have to reverse the channel by referring the **Transmitter Manual**.

	Bank Left		Aileron
	Bank Right		
	Climb		Elevator
	Descend		
	Steer/Yaw Left		Steering Rudder
	Steer/Yaw Right		

Get your model ready to fly

2. Make sure all servo arms are fully vertical. If not, adjust the servo arm by using the trim function on your radio. **Note:** For computerized transmitters, use the servo/channel sub-trim feature to make each servo arm fully vertical.
3. The standard hole settings for linkage connections are shown by the black arrows in the diagram below. You can move the linkage to different hole positions to increase control surface travel and increase the aerobatics of the airplane.

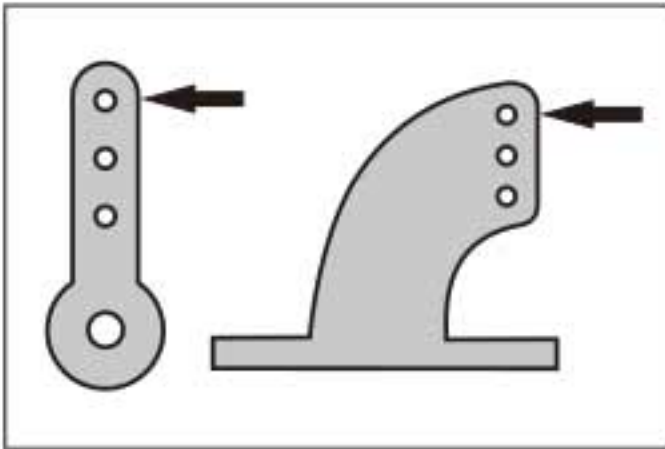

4. Align ailerons with the wing root by turning the clevis clockwise and counterclockwise on the linkage, carefully open the clevis fork and put the clevis pin in the desired hole of the control horn.

Note: Please secure the clevis with provided piece of tube after the alignment of the surface is completed.

Adjust the control connector on the servo arm to align the elevator and the rudder well.

Note: Make sure the tail wheel align with the fuselage centerline by adjusting the connector on the linkage rod.

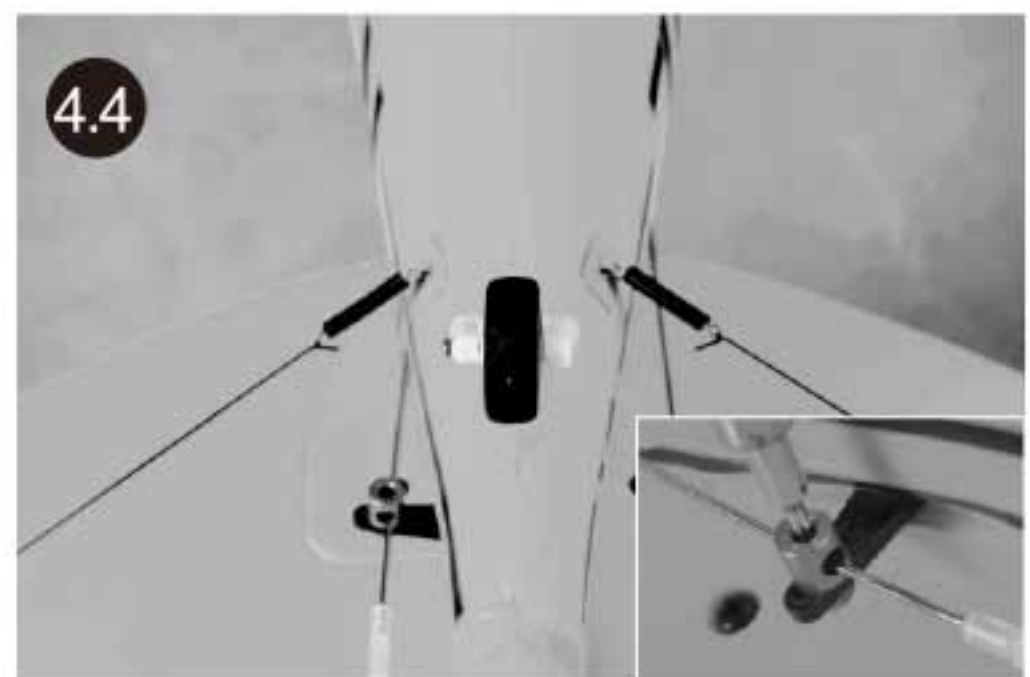
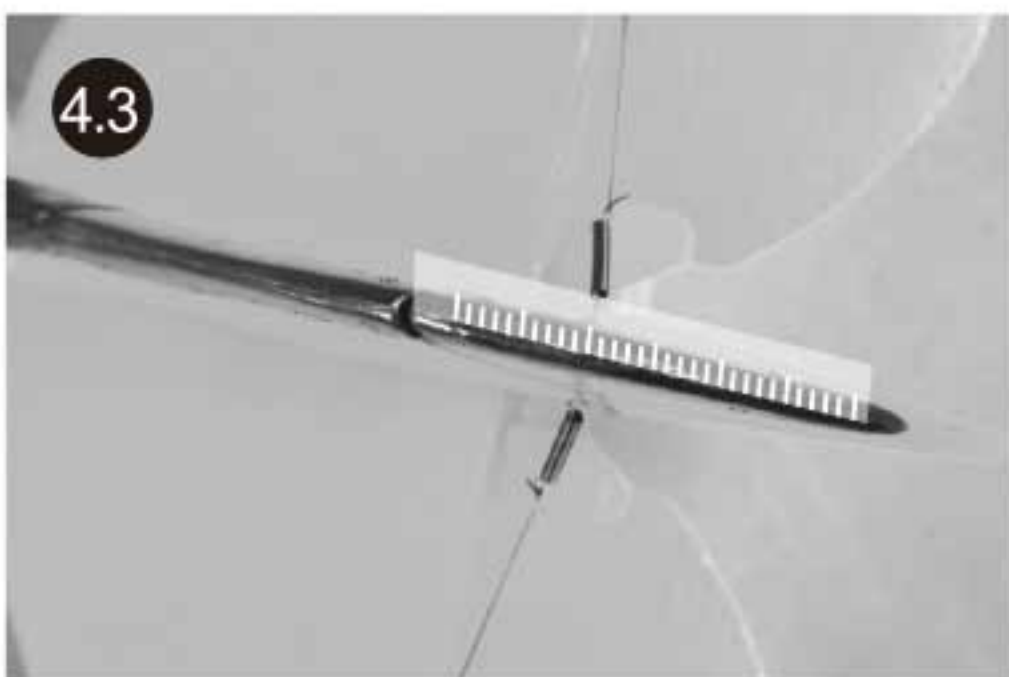
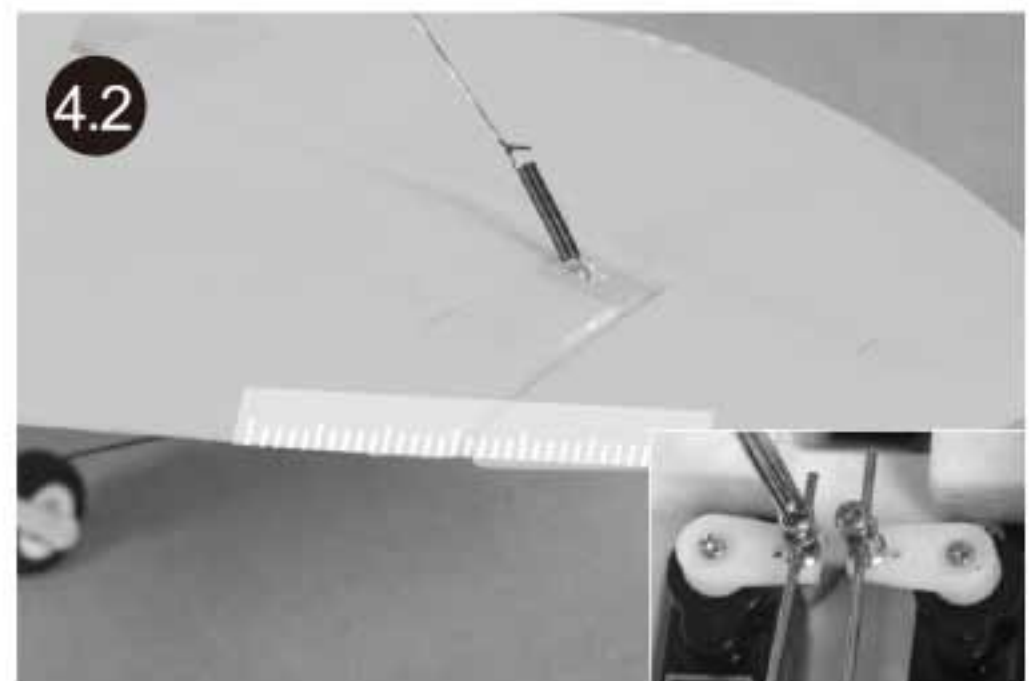
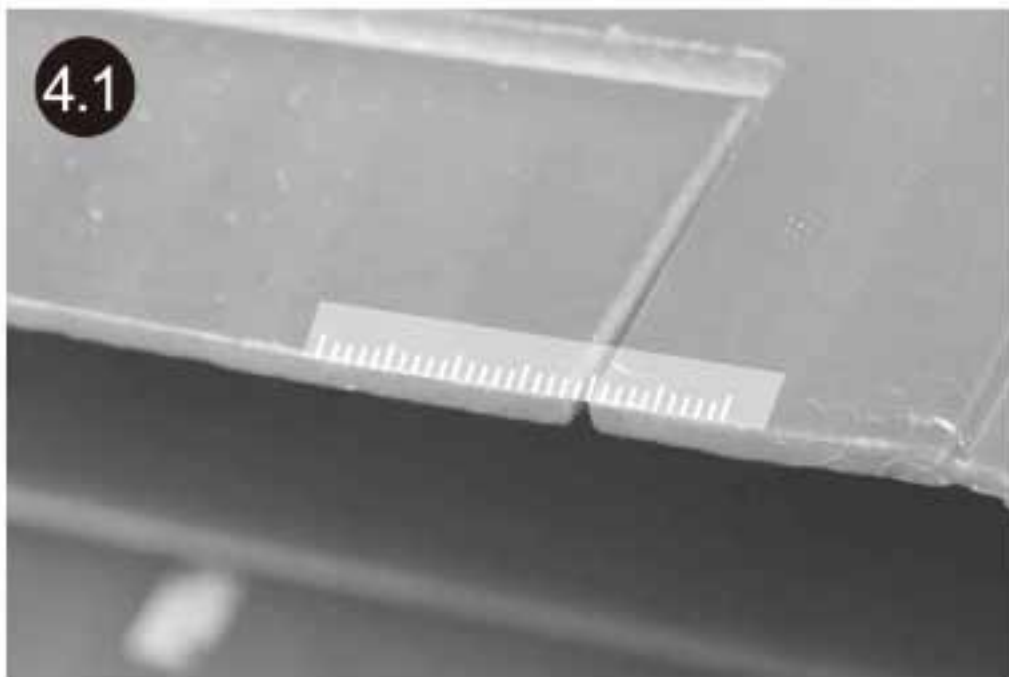

Get your model ready to fly

Check the control throws

The suggested control throw settings for **Roc HOBBY Waco** are as follows (Dual rate setting):

	High Rate	Low Rate
Elevator	15mm up/down	10mm up/down
Aileron	18mm up/down	12mm up/down
Rudder	12mm left/right	8mm left/right

Tips: At first flight, fly the model in low rate. The first time you use high rates, be sure to fly at low to medium speeds. High rates, as listed, are only for EXTREME maneuvering.

Check the motor rotating direction

1. The motor should rotate counter clockwise when viewing the plane from the front.
2. Hand tighten the spinner, make sure it is tight enough.



Install the propeller

1. Keyed the propeller assembly onto the motor shaft fully. Make sure fully keyed the hub on to the hex nut.



Install the flapron linkage

1. Put the Z-bend end of the linkage of the ailerons into the eyelet on top of lower wing control surface, it is a tight fit and should allow the linkage to move just slightly within the hole to avoid binding up.



Get your model ready to fly

2. Snap the clevis into the eyelet on bottom of top wing surface control horn and secure it using the rubber ring.

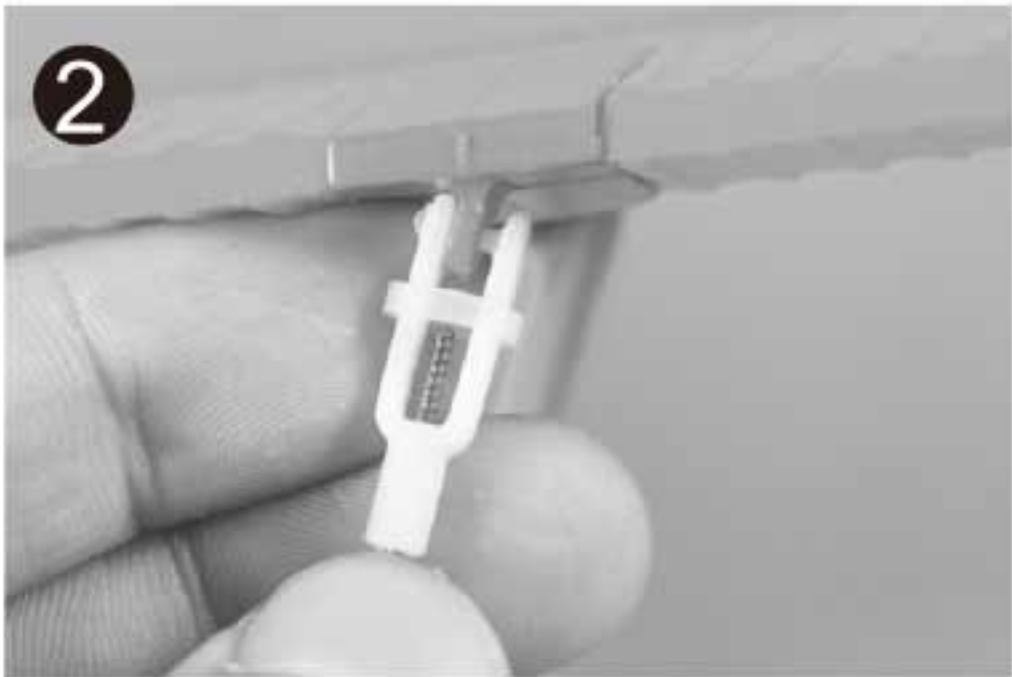

3. Turn the clevis clockwise or counter clockwise to make sure flapron level with either of the wing root.



Install the flying wires and pilot

1. Take proper length of nylon wire and attach to the spring firmly the first, hook it to the eyelet on the stabilizers.

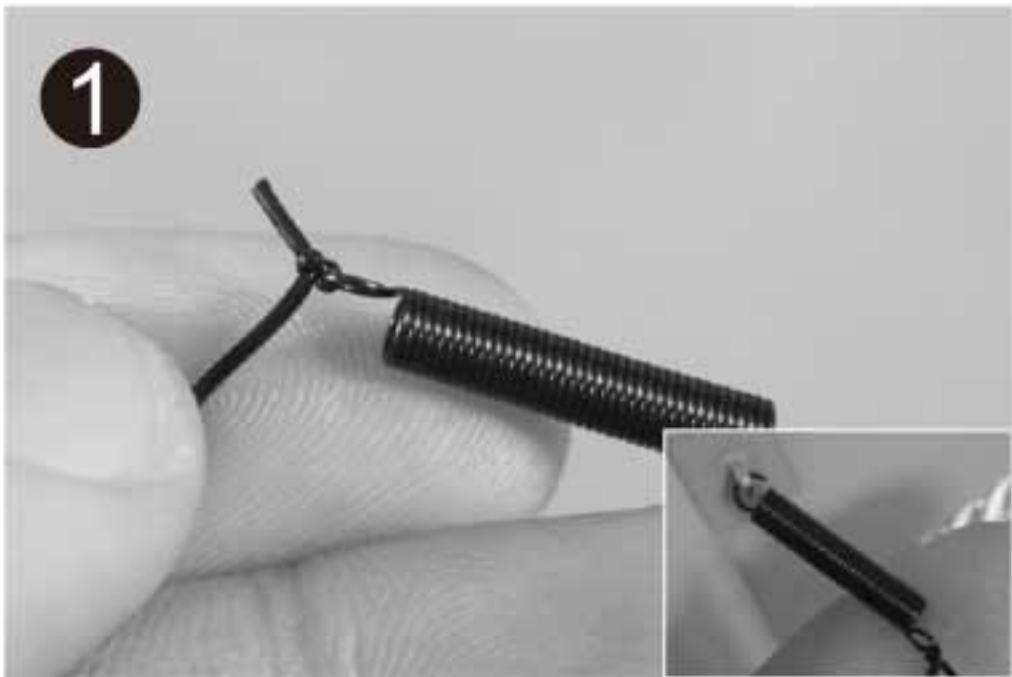

2. Verify the completed stabilizer flying wire linking.

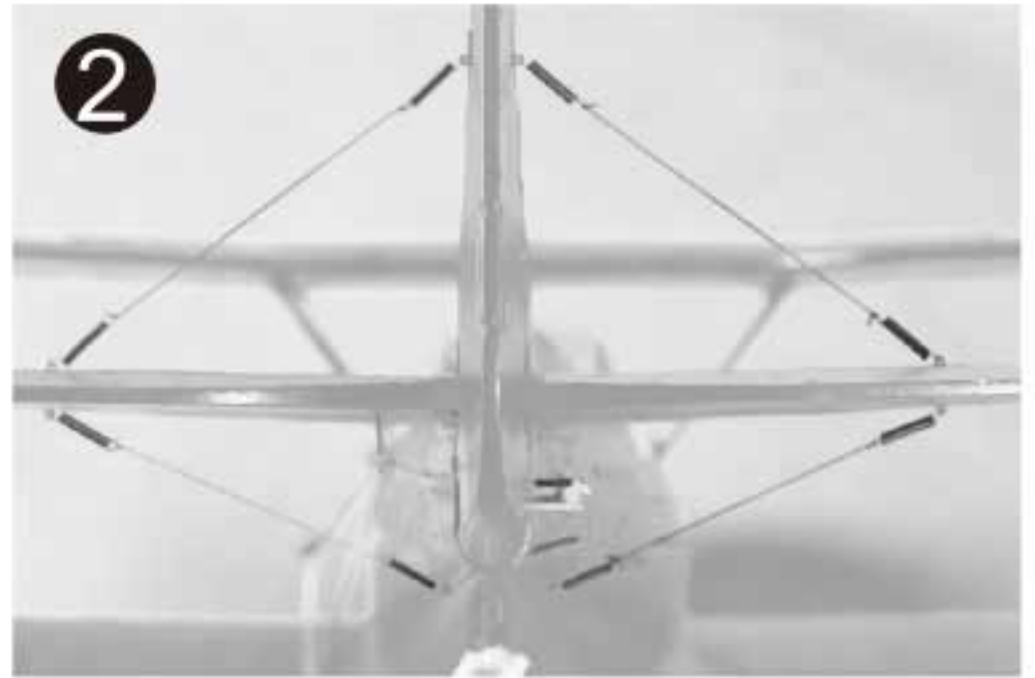

3. Verify the completed wing flying wire connection status with the bottom of the plane face up. Close both end of the spring using a needle nose plier for more reliable linking.

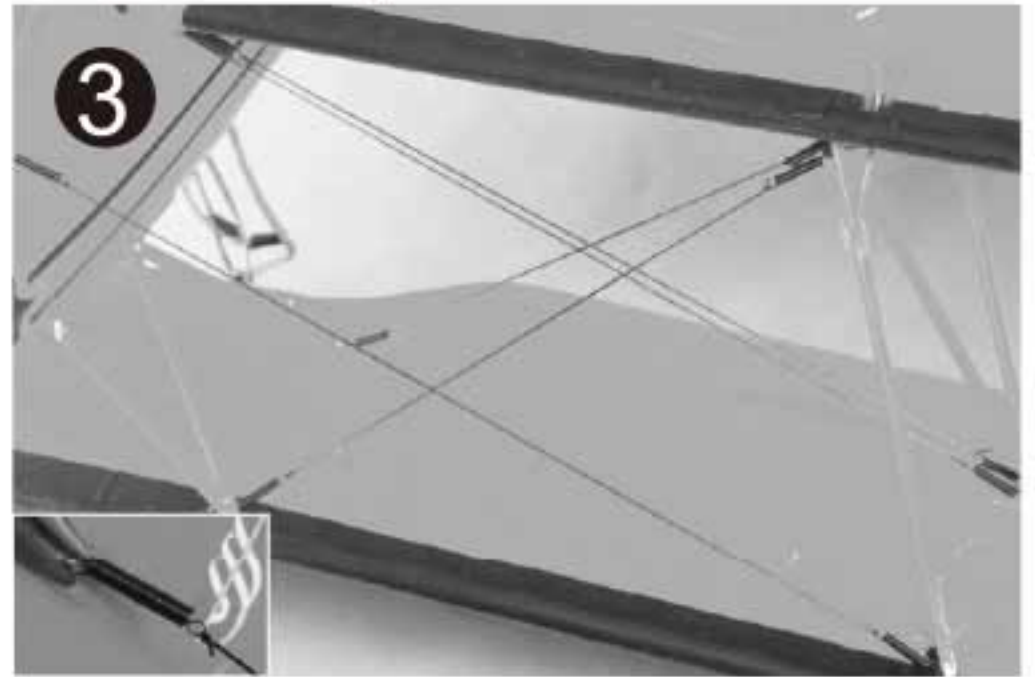

4. Glue the crew members into place.

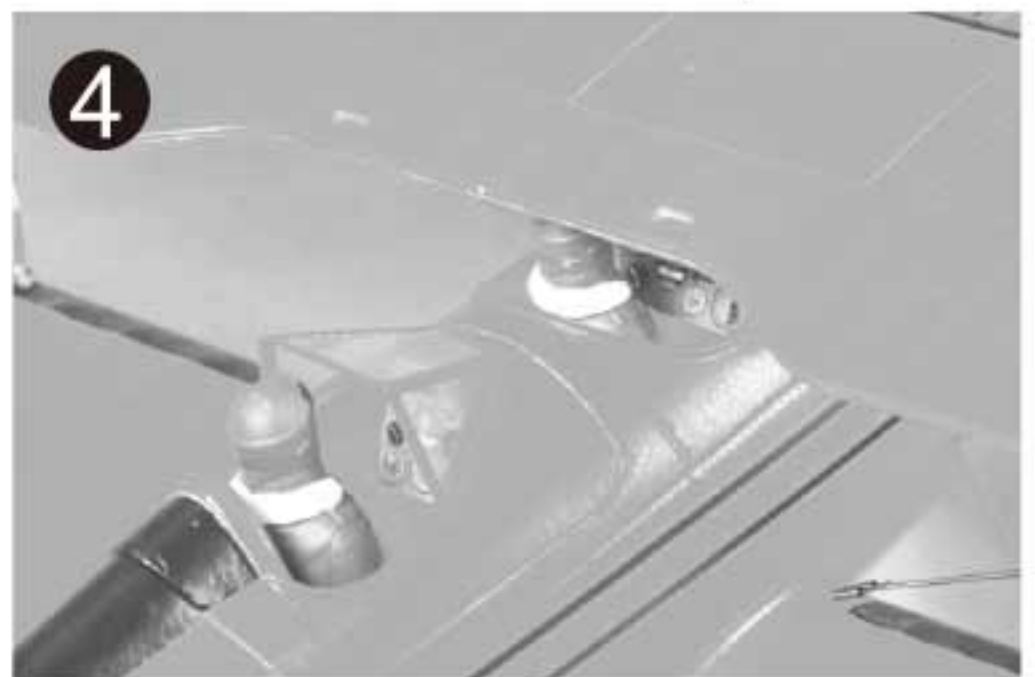

Get your model ready to fly

Check the C.G. (Center of Gravity)

Center of Gravity

When balancing your model, adjust the motor battery as necessary so the model is level or slightly nose down. This is the correct balance point for your model. After the first flights, the **CG** position can be adjusted for your personal preference.

1. The recommended Center of Gravity (**CG**) location for your model is **(85mm/3.4in)** forward from the leading edge of the top wing (as shown) with the battery pack installed. Mark the location of the **CG** on bottom of the wing.
2. When balancing your model, support the plane at the marks made on the bottom of the main wing with your fingers or a commercially available balancing stand. This is the correct balance point for your model. Make sure the model is assembled and ready for flight before balancing.



Before the model flying

Find a suitable flying site

Find a flying site clear of buildings, trees, power lines and other obstructions. Until you know how much area will be required and have mastered flying your plane in confined spaces, choose a site which is at least the size of two to three football fields – a flying field specifically for R/C planes is best. Never fly near people– especially children who can wander unpredictably.

Perform the range check of your plane

As a precaution, an operational ground range test should be performed before the first flight each time you go out. Performing a range test is a good way to detect problems that could cause loss of control such as low batteries, defective or damaged radio components, or radio interference. This usually requires an assistant and should be done at the actual flying site you will be using.

First turn on the transmitter, then install a fully-charged battery into the fuselage. Connect the battery and install the hatch.

Remember, use care not to bump the throttle stick, otherwise, the propeller / fan will turn and possibly cause damage or injury.

Note: Please refer to your Transmitter Manual that came with your radio control system to perform a ground range check. If the controls are not working correctly or if anything seems wrong, do not fly the model until you correct the problem. Make certain all the servo wires are securely connected to the receiver and the transmitter batteries have a good connection.

Monitor your flight time

Monitor and limit your flight time using a timer (such as one on a wrist watch or in your transmitter if available). When the batteries are getting low you will usually notice a performance drop before the ESC cuts off motor power, so when the plane starts flying slower you should land. Often (but not always) power can be briefly restored after the motor cuts off by holding the throttle stick all the way down for a few seconds.

To avoid an unexpected dead-stick landing on your first flight, set your timer to a conservative 4 minutes. When your alarm sounds you should land right away.

Flying course

Take off

While applying power slowly steer to keep the model straight, the model should accelerate quickly. As the model gains flight speed, you will want to climb at a steady and even rate. The **Waco** will climb out at a nice angle of attack (AOA).

Flying

Always choose a wide-open space for flying your plane. It is ideal for you to fly at a sanctioned flying field. If you are not flying at an approved site, always avoid flying near houses, trees, wires and buildings. You should also be careful to avoid flying in areas where there are many people, such as busy parks, schoolyards, or soccer fields. Consult laws and ordinances before choosing a location to fly your aircraft. After takeoff, gain some altitude. Climb to a safe altitude and begin to trim the model till it's tracks well through all aspects of flight, including high speed passes, inverted flight, loops, and point rolls.

Landing

Land the model when you hear the motor pulsing (LVC) or if you notice a reduction in power. If using a transmitter with a timer, set the timer so you have enough flight time to make several landing approaches.

Recharge the battery and repair the model as needed. The model's three point landing gear allows the model to land on hard surfaces. Align model directly into the wind and fly down to the ground. Fly the airplane down to the ground using 1/4-1/3 throttle to keep enough energy for proper flare. Before the model touches down, always fully decrease the throttle to avoid damaging the propeller or other components. The key to a great landing is to manage the power and elevator all the way to the ground and set down lightly on the main landing gear. After a few flights you will find the model can be set down lightly on the mains and you can hold the nose wheel off balancing the model on the mains till it slows and gently settles the nose.

Maintenance

Repairs to the foam should be made with foam safe adhesives such as hot glue, foam safe CA, and 5 min epoxy. When parts are not repairable, see the Spare Parts List for ordering by item number.

Always check to make sure all screws on the aircraft are tightened. Pay special attention to make sure the spinner is firmly grabbed in place before every flight.

Troubleshooting

Problem	Possible Cause	Solution
Aircraft will not respond to the throttle but responds to other controls.	<ul style="list-style-type: none"> - ESC is not armed. - Throttle channel is reversed. 	<ul style="list-style-type: none"> - Lower throttle stick and throttle trim to lowest settings. - Reverse throttle channel on transmitter.
Extra propeller noise or extra Vibration.	<ul style="list-style-type: none"> - Damaged spinner, propeller, motor, or motor mount. - Loose propeller and spinner parts. - Propellor installed backwards. 	<ul style="list-style-type: none"> - Replace damaged parts. - Tighten parts for propeller adapter, propeller and spinner.
Reduced flight time or aircraft underpowered.	<ul style="list-style-type: none"> - Flight battery charge is low. - Propeller installed backward. - Flight battery damaged. 	<ul style="list-style-type: none"> - Remove and install propeller correctly. - Completely recharge flight battery. - Replace flight battery and obey flight battery instructions.
Control surface does not move, or is slow to respond to control inputs.	<ul style="list-style-type: none"> - Control surface, control horn, linkage or servo damage. - Wire damaged or connections loose. 	<ul style="list-style-type: none"> - Replace or repair damaged parts and adjust controls. - Do a check of connections for loose wiring.
Controls reversed.	Channels are reversed in the transmitter.	Do the Control Direction Test and adjust controls for aircraft and transmitter.
<ul style="list-style-type: none"> - Motor loses power. - Motor power pulses then motor loses power. 	<ul style="list-style-type: none"> - Damage to motor, or battery. - Loss of power to aircraft. - ESC uses default soft Low Voltage Cutoff(LVC). 	<ul style="list-style-type: none"> - Do a check of batteries, transmitter, receiver, ESC, motor and wiring for damage (replace as needed). - Land aircraft immediately and Recharge flight battery.
LED on receiver flashes slowly.	Power loss to receiver.	<ul style="list-style-type: none"> - Check connection from ESC to receiver. - Check servos for damage. - Check linkages for binding.

AMA

If you are not already a member of the AMA, please join, The AMA is the governing body of model aviation and membership provided liability insurance coverage, protects modelers' rights and interests and is required to fly at most R/C sites.

Academy of Model Aeronautics

5151 East Memorial Drive

Muncie, IN 47302-9252

Ph.(800)435-9262

Fax(765)741-0057

Or via the Internet at: <http://www.modelaircraft.org>



Academy of Model Aeronautics National Model Aircraft Safety Code

Effective January 1, 2011

- A. GENERAL:** A model aircraft is a non-human-carrying aircraft capable of sustained flight in the atmosphere. It may not exceed limitations of this code and is intended exclusively for sport, recreation and/or competition.
All model flights must be conducted in accordance with this safety code and any additional rules specific to the flying site.
1. Model aircraft will not be flown:
 - (a) In a careless or reckless manner.
 - (b) At a location where model aircraft activities are prohibited.
 2. Model aircraft pilots will:
 - (a) Yield the right of way to all man carrying aircraft.
 - (b) See and avoid all aircraft and a spotter must be used when appropriate.
(AMA Document #540-D-See and Avoid Guidance.)
 - (c) Not fly higher than approximately 400 feet above ground level within three (3) miles of an airport, without notifying the airport operator.
 - (d) Not interfere with operations and traffic patterns at any airport, heliport or seaplane base except where there is a mixed use agreement.
 - (e) Ensure the aircraft is identified with the name and address or AMA number of the owner on the inside or affixed to the outside of the model aircraft.
(This does not apply to model aircraft flown indoors).
 - (f) Not operate aircraft with metal-blade propellers or with gaseous boosts except for helicopters operated under the provisions of AMA Document #555.
 - (g) Not operate model aircraft while under the influence of alcohol or while using any drug which could adversely affect the pilot's ability to safely control the model.
 - (h) Not operate model aircraft carrying pyrotechnic devices which explode or burn, or any device which propels a projectile or drops any object that creates a hazard to persons or property.

AMA

Exceptions:

- ◆ Free Flight fuses or devices that burn producing smoke and are securely attached to the model aircraft during flight.
- ◆ Officially designated AMA Air Show Teams (AST) are authorized to use devices and practices as defined within the Team AMA Program Document (AMA Document #718).
- 3. Model aircraft will not be flown in AMA sanctioned events, air shows or model demonstrations unless:
 - (a) The aircraft, control system and pilot skills have successfully demonstrated all maneuvers intended or anticipated prior to the specific event.
 - (b) An inexperienced pilot is assisted by an experienced pilot.
- 4. When and where required by rule, helmets must be properly worn and fastened. They must be OSHA, DOT, ANSI, SNELL or NOCSAE approved or comply with comparable standards.

B. RADIO CONTROL (RC)

1. All pilots shall avoid flying directly over unprotected people, vessels, vehicles or structures and shall avoid endangerment of life and property of others.
2. A successful radio equipment ground-range check in accordance with manufacturer's recommendations will be completed before the first flight of a new or repaired model aircraft.
3. RC model aircraft must use the radio-control frequencies currently allowed by the Federal Communications Commission (FCC). Only individuals properly licensed by the FCC are authorized to operate equipment on Amateur Band frequencies.
4. RC model aircraft will not operate within three (3) miles of any pre-existing flying site without a frequency-management agreement (AMA Documents #922-Testing for RF Interference; #923- Frequency Management Agreement)
5. With the exception of events flown under official AMA Competition Regulations, excluding takeoff and landing, no powered model may be flown outdoors closer than 25 feet to any individual, except for the pilot and the pilot's helper(s) located at the flight line.
6. Under no circumstances may a pilot or other person touch a model aircraft in flight while it is still under power, except to divert it from striking an individual. This does not apply to model aircraft flown indoors.
7. RC night flying requires a lighting system providing the pilot with a clear view of the model's attitude and orientation at all times.
8. The pilot of a RC model aircraft shall:
 - (a) Maintain control during the entire flight, maintaining visual contact without enhancement other than by corrective lenses prescribed for the pilot.
 - (b) Fly using the assistance of a camera or First-Person View (FPV) only in accordance with the procedures outlined in AMA Document #550.

C. FREE FLIGHT

1. Must be at least 100 feet downwind of spectators and automobile parking when the model aircraft is launched.
2. Launch area must be clear of all individuals except mechanics, officials, and other fliers.
3. An effective device will be used to extinguish any fuse on the model aircraft after the fuse has completed its function.



Email:info@rochobby.com
[Http://www.rochobby.com](http://www.rochobby.com)

MADE IN CHINA