

Name: Ryan Dunford	Date:	Event:	Track: Standard Setup
Track Conditions			
<input type="checkbox"/> Indoor	<input checked="" type="checkbox"/> Tight	<input type="checkbox"/> Smooth	<input type="checkbox"/> Hard Packed
<input type="checkbox"/> Blue Groove	<input checked="" type="checkbox"/> Wet	<input type="checkbox"/> Low Bite	<input type="checkbox"/> High Bite
<input checked="" type="checkbox"/> Outdoor	<input checked="" type="checkbox"/> Open	<input checked="" type="checkbox"/> Rough	<input checked="" type="checkbox"/> Loose/Loamy
<input checked="" type="checkbox"/> Dry	<input type="checkbox"/> Dusty	<input checked="" type="checkbox"/> Med Bite	<input type="checkbox"/> Other

Front Suspension

Ride Ht	27mm
Camber	-1.5
Toe	1 out
Sway Bar	2.5mm
Notes:	Pro-RC drag link at 0 location
Arm Bushings	

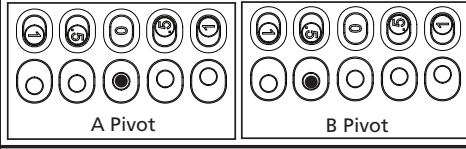
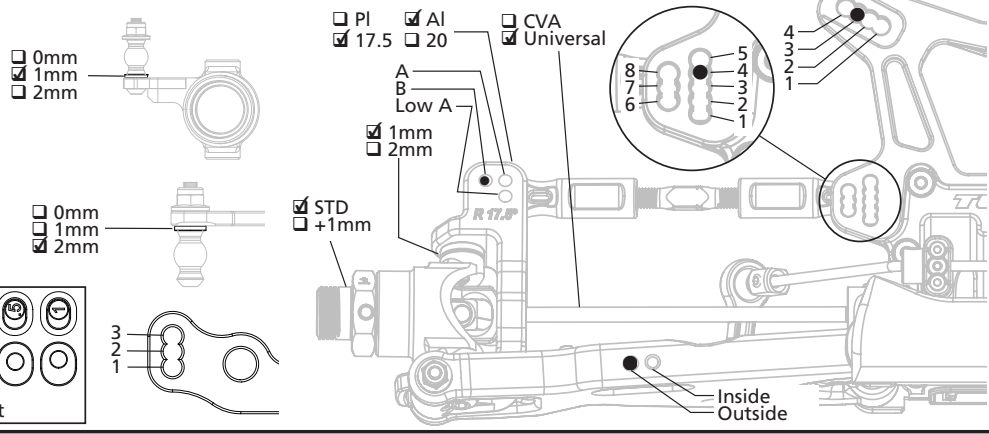

Rear Suspension

Ride Ht	27mm
Camber	-1.5
Sway Bar	2.6mm
Notes:	Lit-RC C block inside/down
	Light rear ring gear
	Arm Bushings

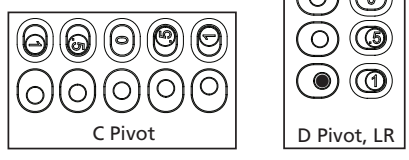
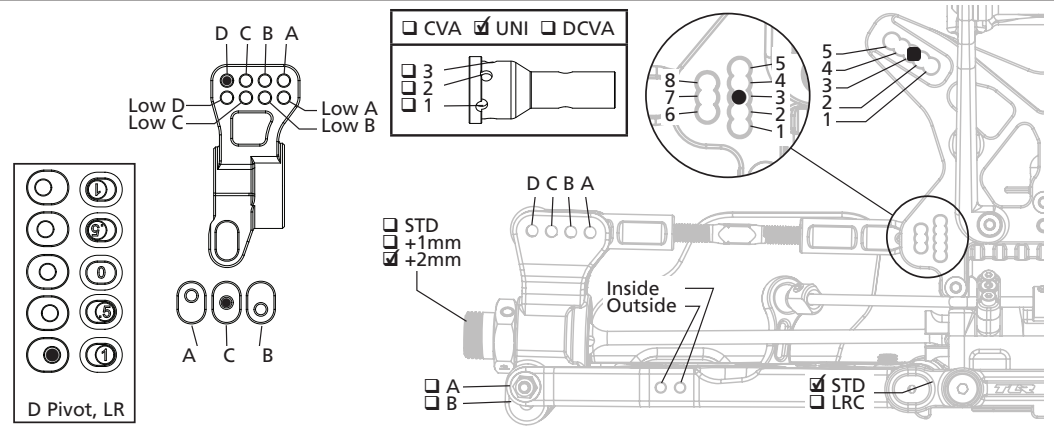

Chassis

Differentials			Wing		Electronics		
	Front	Center	Rear	Brand	HB	Radio	Servo
Fluid	7k	6k	4k			DX6R	S6290
Pins	<input checked="" type="checkbox"/> AL <input type="checkbox"/> STL	<input checked="" type="checkbox"/> AL <input type="checkbox"/> STL	<input checked="" type="checkbox"/> AL <input type="checkbox"/> STL	<input checked="" type="checkbox"/> Riser		ESK	Tekin RX8
Case	<input checked="" type="checkbox"/> STD <input type="checkbox"/> HD	<input type="checkbox"/> STD <input checked="" type="checkbox"/> HD	<input checked="" type="checkbox"/> STD <input type="checkbox"/> HD	<input checked="" type="checkbox"/> Wicker Bill		Motor	Tekin 1900
				<input checked="" type="checkbox"/> FWD <input type="checkbox"/> Back		Battery	Spek 5000
						Initial Brake	
						Thro Prof	
						Thro Expo	

Shocks		
	Front	Rear
Shock Type	<input type="checkbox"/> Bladder <input type="checkbox"/> Re Bladder <input checked="" type="checkbox"/> Emulsion <input type="checkbox"/> Vented	<input type="checkbox"/> Bladder <input type="checkbox"/> Re Bladder <input checked="" type="checkbox"/> Emulsion <input type="checkbox"/> Vented
Shaft Dia	<input checked="" type="checkbox"/> 3.5 <input type="checkbox"/> 4.0	<input checked="" type="checkbox"/> 3.5 <input type="checkbox"/> 4.0
Piston	5x1.5 taper down	4x1.5, 1x1.9 taper down
Oil	47	42
Spring	Gold HB	Brown Evo
Stroke		
Droop	28	25

Tires		
	Front	Rear
Brand	Proline	Proline
Tread	Holeshot	Holeshot
Compound	M3	M3
Insert		
Sauce		

