



SC410SE

BUILDING
INSTRUCTIONS

INTRODUCTION



Thank you for purchasing the Tekno RC SCT410SL 1/10th 4x4 Lightweight Short Course Truck Kit. We are always working on new projects, so please check our website regularly at www.teknorc.com or visit us on Facebook at www.facebook.com/teknorc for all the latest news, parts, and kits.

Take your time! When you work your way through these building instructions, keep an eye out for the following important indicators below:

- **RED TEXT** - *This indicates important areas of the build process that should be observed.*



Thread Lock icons

Thread lock is always used when a screw is inserted into any metal part. (Included with kit)



Grease icons

Grease is usually used on areas with movement and for sealing. (Included with kit)

- **YOUTUBE** - *We also have many useful build videos on Youtube, so be sure to check these out!*
<https://www.youtube.com/c/teknorc>

Additional equipment and parts needed:

- 2 Channel radio and receiver
- 540-550 4 pole motor system and compatible ESC
- Standard size high torque steering servo (at least 240 oz/in)
** Running less than the recommended rating will increase the chance of premature servo failure.*
- 2S (2 cell, 7.4v) shorty or full size LiPo battery
- 1/10th scale SCT body
- 1/10th scale SCT wheels & tires, CA glue (or premounts)
- 32 pitch pinion gear (16 tooth - 21 tooth)

Tools needed:

- Hex drivers 1.5mm, 2.0mm, 2.5mm
- Nut drivers 5.5mm (TKR1108), 7.0mm (TKR1109)
- Hobby knife
- Needle-nose pliers
- Shock tool (TKR1115) OR adjustable (Crescent) wrench (for shock assembly)
- 4mm turnbuckle wrench (TKR1103) AND 5.5/7.0 two sided wrench (TKR1119)
- Body reamer

Disclaimer: Tekno RC is not responsible or liable for any property or personal damage, loss, or injury incurred as a result of using this product. This kit is meant for use by persons 14 years of age or older and in the strict confines of a legally permitted RC track or facility.

Warnings: Always double-check that your radio gear is working properly before operating vehicle. Never operate the vehicle indoors (unless the RC track is an indoor facility). Use caution while operating vehicle so as not to collide with people who may be turn marshalling or who might otherwise not be aware that a fast moving RC vehicle is in the vicinity.

Warranty: We warrant that the parts included in this kit are free from defects. If you find a defective part in your kit, please contact us at info@teknorc.com and we will help to resolve the issue. If you modify any part prior to contacting us, the warranty claim will be void. We do not warranty parts that may be broken during operation of the vehicle or otherwise. Refer to the end of this instruction manual for a listing of spare/replacement and option parts. All spare parts and other info are available on our website (www.teknorc.com) and through our network of domestic and international dealers and distributors.

Bag A

Center Differential (overview)

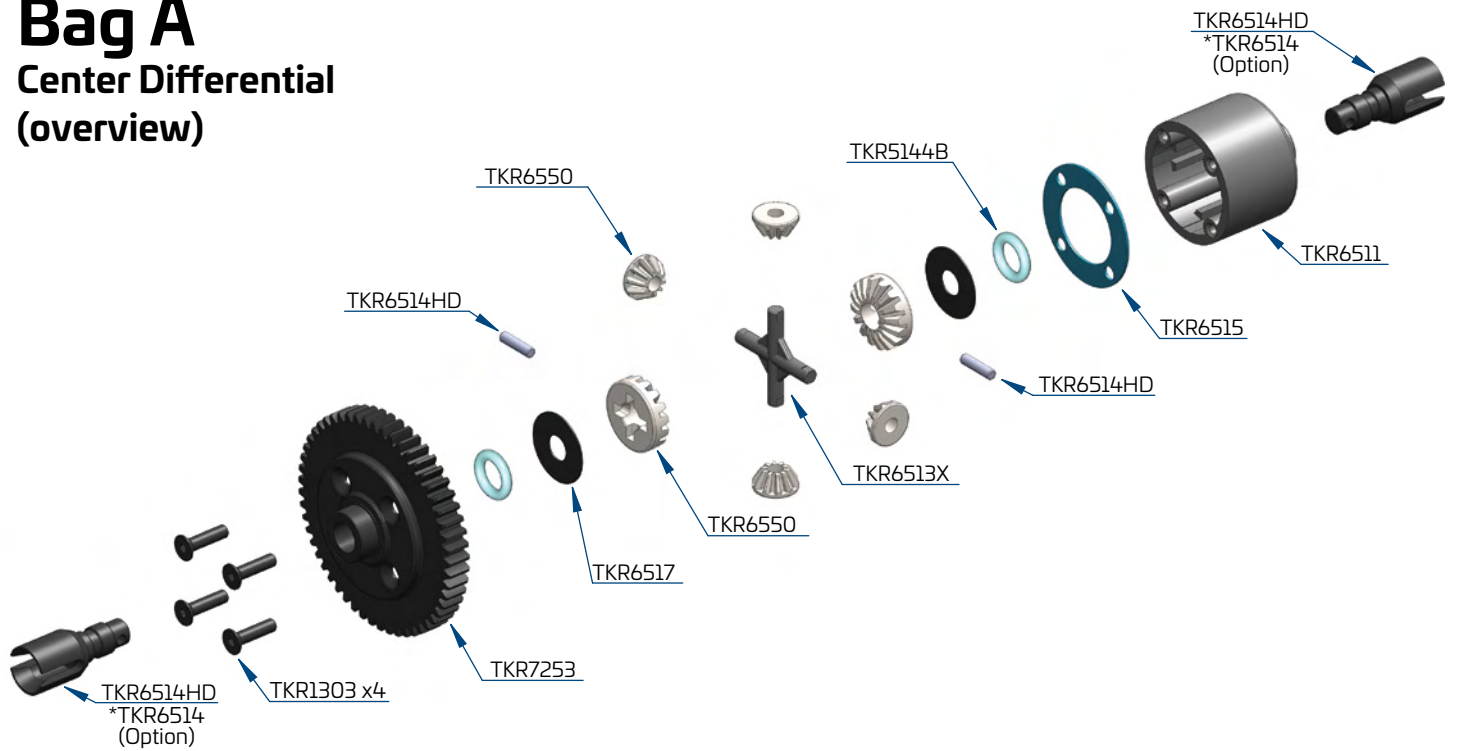

Step A-1

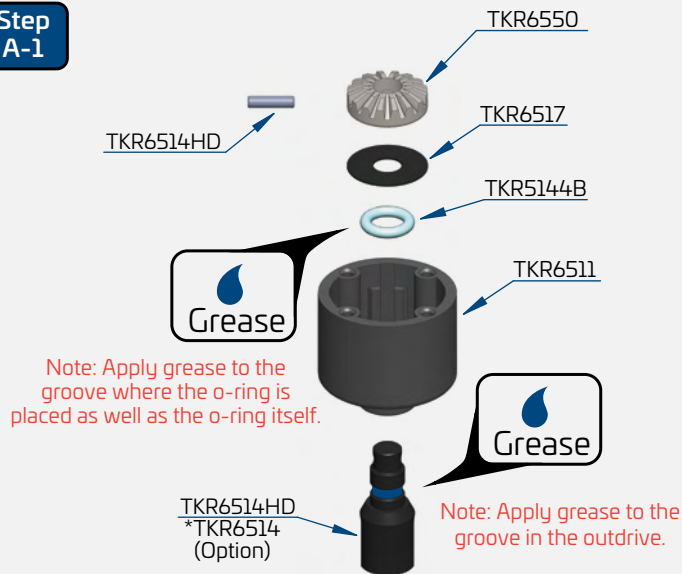

Step A-2

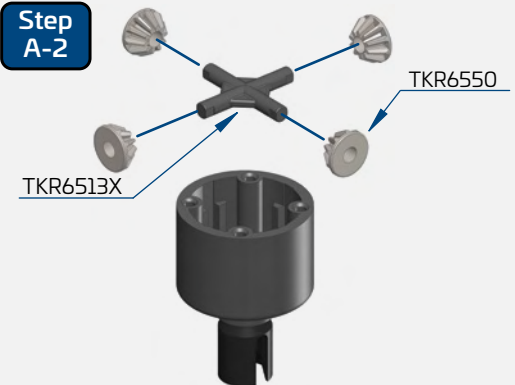

Step A-4



Step A-3



x4
TKR1303
M2.5x10mm Flat Head Screw

x2
TKR5144B
Differential O-rings

x2
TKR6517
Differential Shims (5x14mm)

Bag B

Front and Rear Differential (overview)

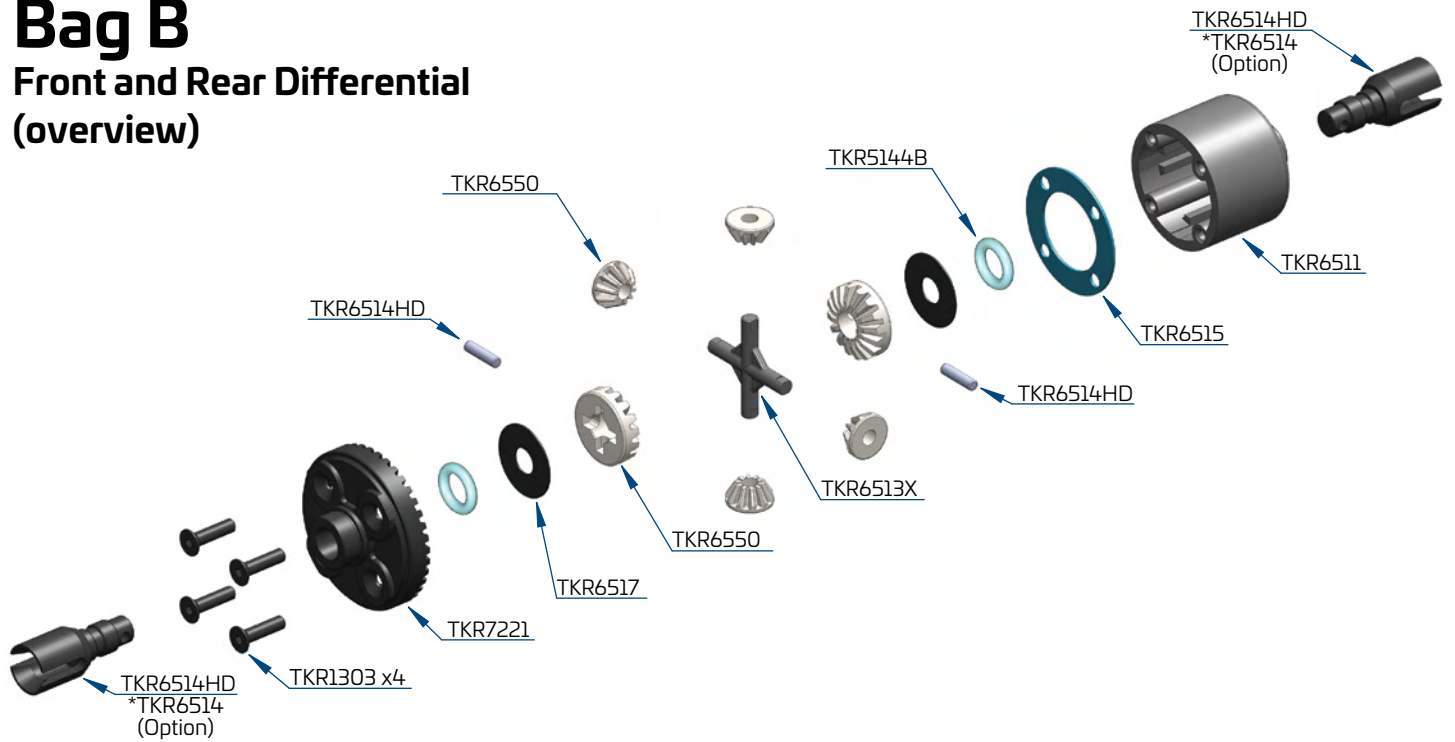

Step B-1

Repeat for rear diff



Step B-2

Repeat for rear diff

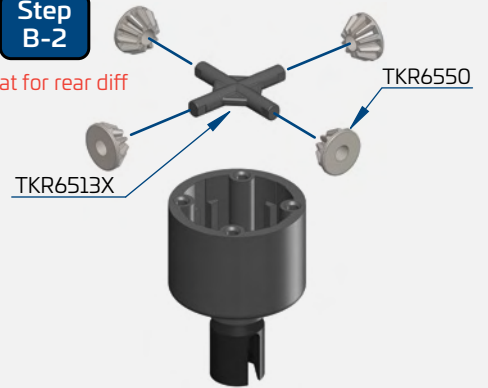

Step B-4

Repeat for rear diff

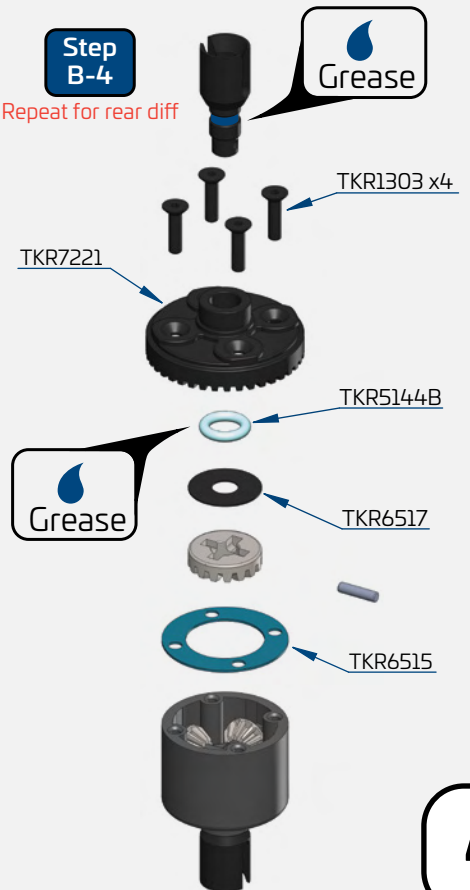

Step B-3

Repeat for rear diff

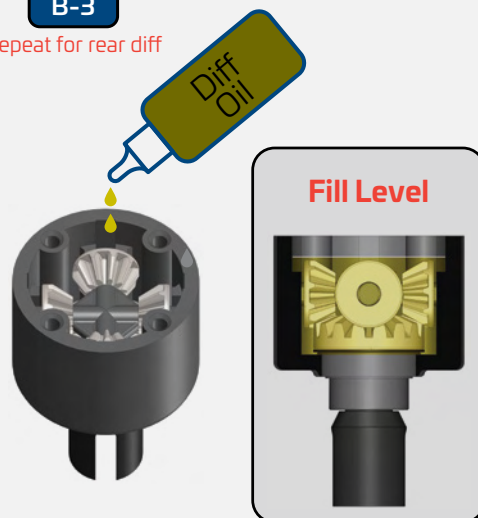

Fill FRONT with #30,000 CST oil
Fill REAR with #20,000 CST oil
to 1mm below full
DO NOT OVER FILL

x8
TKR1303
M2.5x10mm Flat Head Screw

x4
TKR5144B
Differential O-rings

x4
TKR6517
Differential Shims (5x14mm)

Bag C

Steering/Bulkhead Assembly

Step C-1

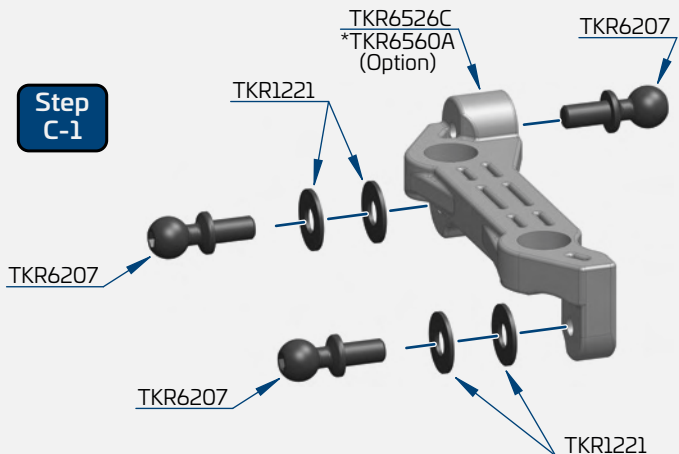

Step C-2

* Thread Lock

Note: Use a 5.5mm wrench (TKR1119) here to assist in tightening this assembly.

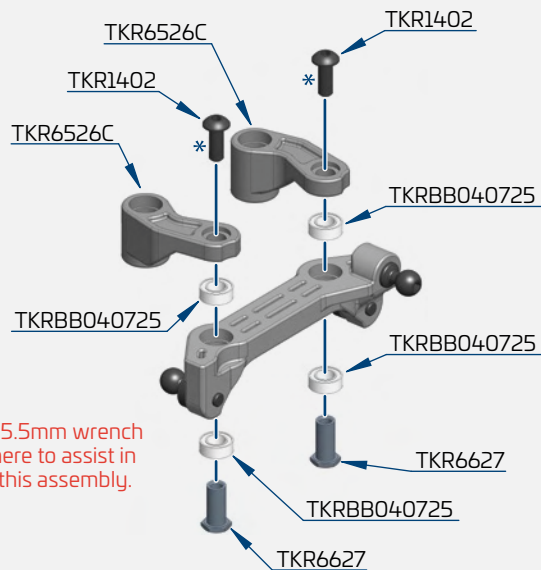

Step C-3

* Thread Lock

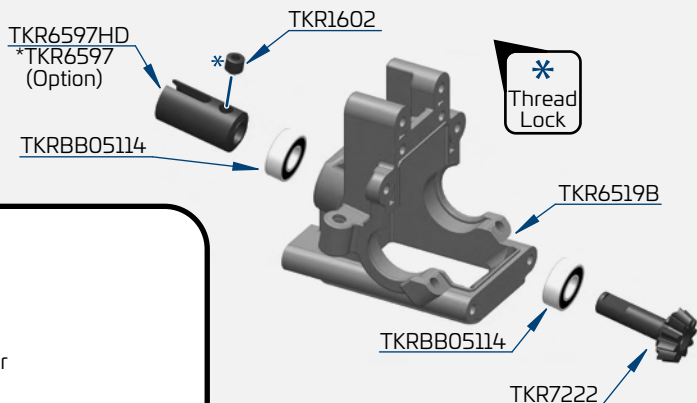

Step C-4

Note: Use a 2mm hex to pre-thread the steering posts into the bulkhead.

This will ensure that the posts go in as straight as possible. After pre-threading, remove the posts and re-install them with the entire steering assembly as shown.

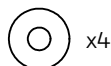
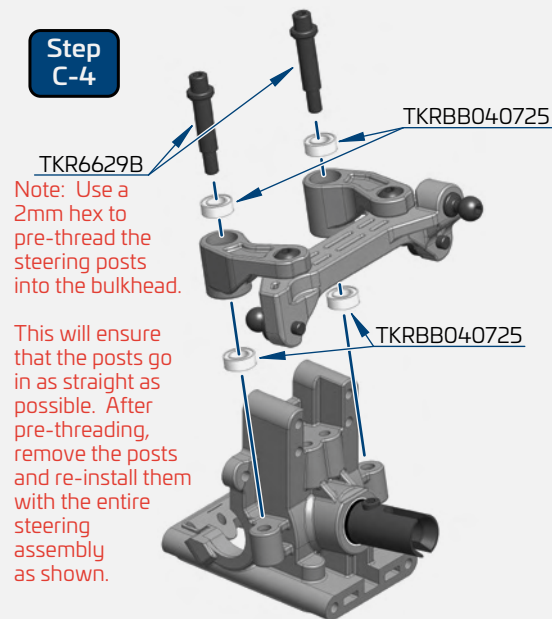

x4

TKR1221
M3x8mm Washer



x2

TKR1301
M2.5x6mm Flat Head Screw

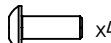

x4

TKR1402
M3x8mm Button Head Screw

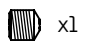

x1

TKR1602
M4x4mm Set Screw



x4

TKRBB040725
Ball Bearing (4x7x2.5)



x2

TKRBB05114
Ball Bearing (5x11x4)



x2

TKRBB10154
Ball Bearing (10x15x4)



x3

TKR6207
M3x6mm Ball Stud

Step C-5

Grease

Note: Screw the TKR1402's all the way down, then back off 1/4 turn.

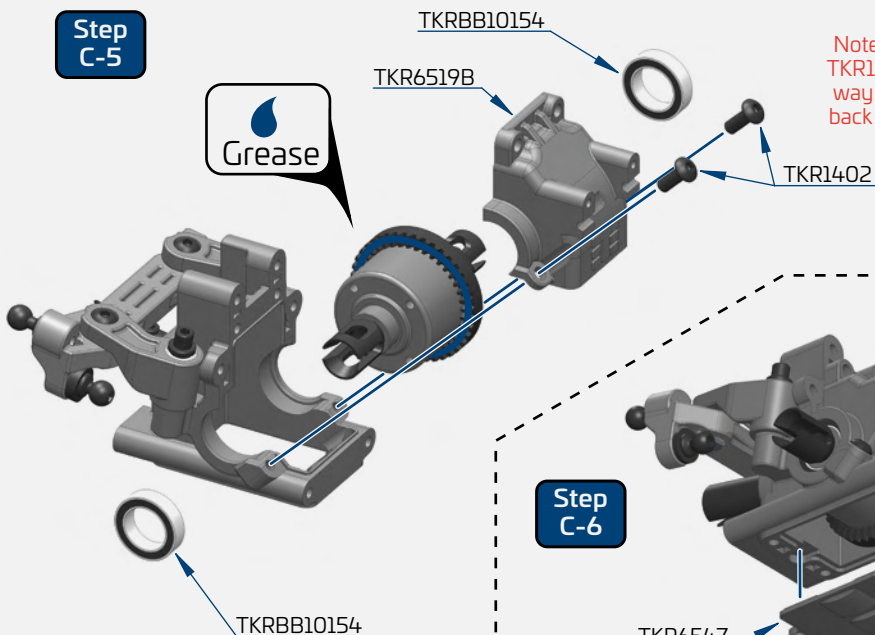

Step C-6

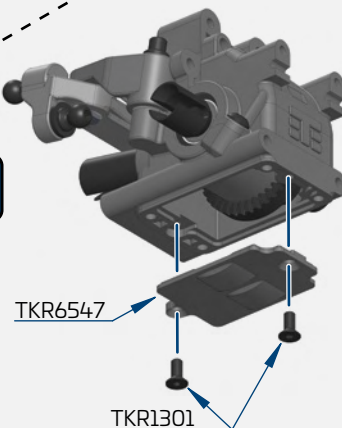

5

Bag D

Rear Bulkhead Assembly

Step
D-1

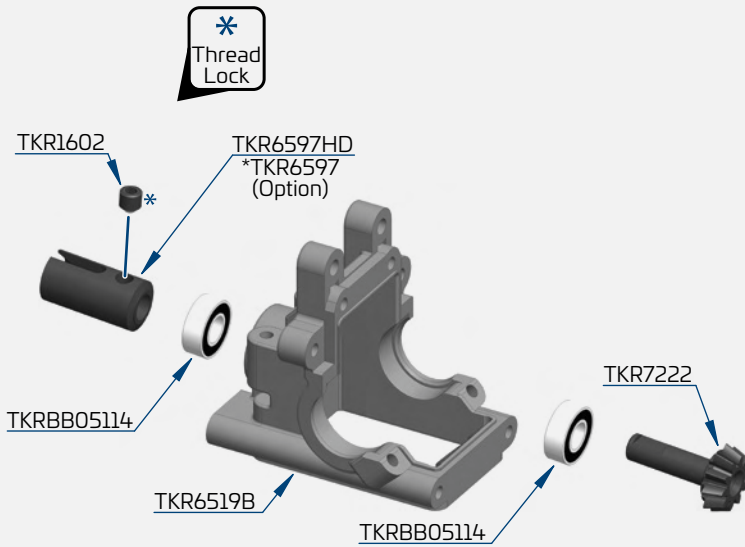

Step
D-2

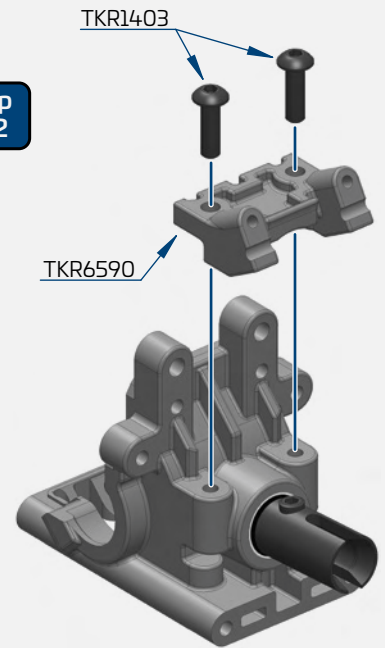

Step
D-3

Note: Screw the TKR1402's all the way down, then back off 1/4 turn. DO NOT OVER-TIGHTEN.

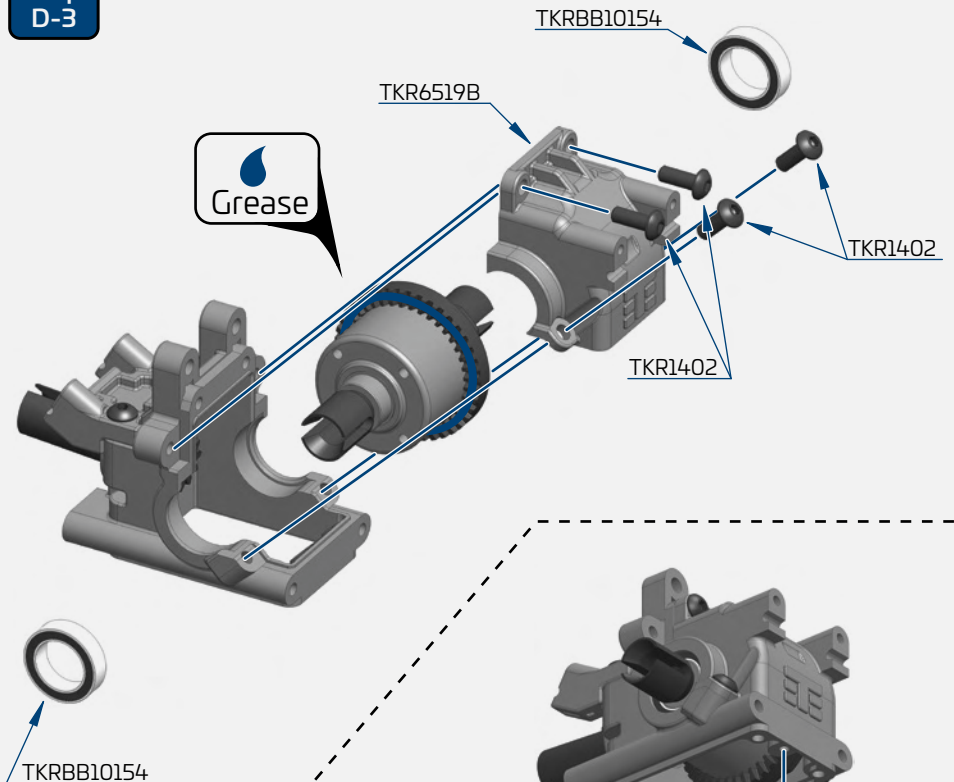

Step
D-4

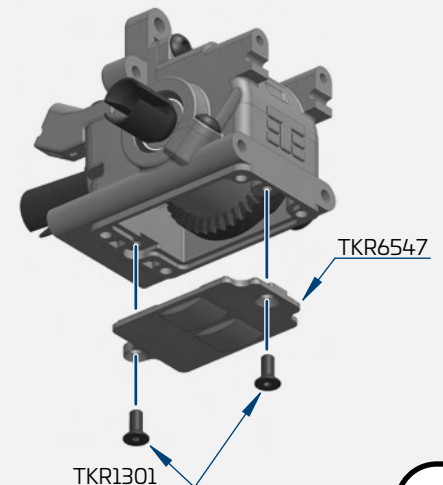

x2
TKR1301
M2.5x6mm Flat Head Screw

x4
TKR1402
M3x8mm Button Head Screw

x2
TKR1403
M3x10mm Button Head Screw

x1
TKR1602
M4x4mm Set Screw

x2
TKRBB05114
Ball Bearing (5x11x4)

x2
TKRBB10154
Ball Bearing (10x15x4)

Bag E

Rear End Assembly

Step E-1

TKR6610 - 1.5mm
 Below options sold separately.
 *TKR6610 - 1.6mm
 *TKR6610 - 1.7mm
 *TKR6610 - 1.8mm
 *TKR6610 - 1.9mm
 (Option)

TKR1601
 Note: Do not over-tighten.

TKR6547

Step E-2

TKR1601
 Note: Screw these set screws in gently, until they just touch the sway bar, then back off just slightly so the sway bar is free.

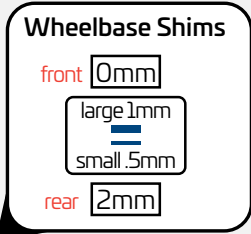
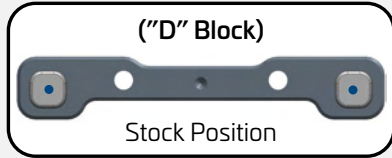
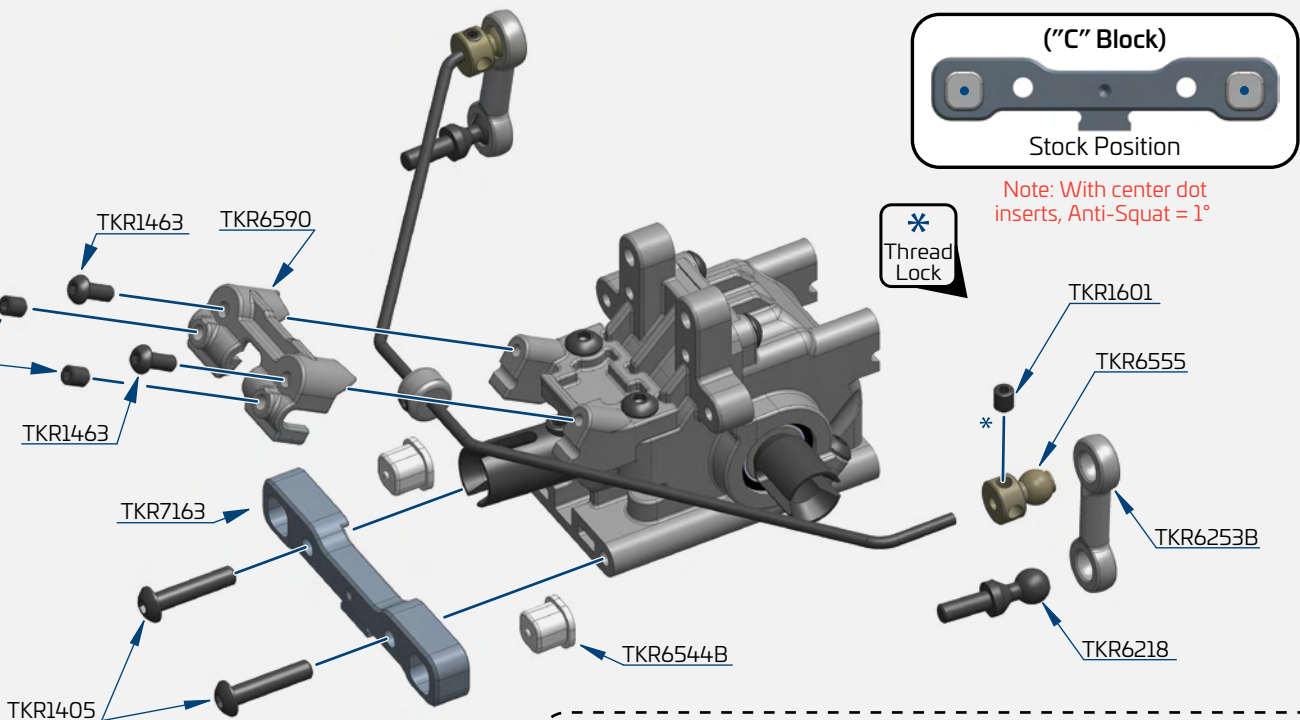

Step E-3

x2
 TKR1405
 M3x14mm Button Head Screw

x2
 TKR1408
 M3x18mm Button Head Screw

x2
 TKR1463
 M2.5x6mm Button Head Screw

x5
 TKR1601
 M3x4mm Set Screw

x2
 TKR1611
 M4x8mm Set Screw

x2
 TKR6218
 M3x8mm Ball Stud

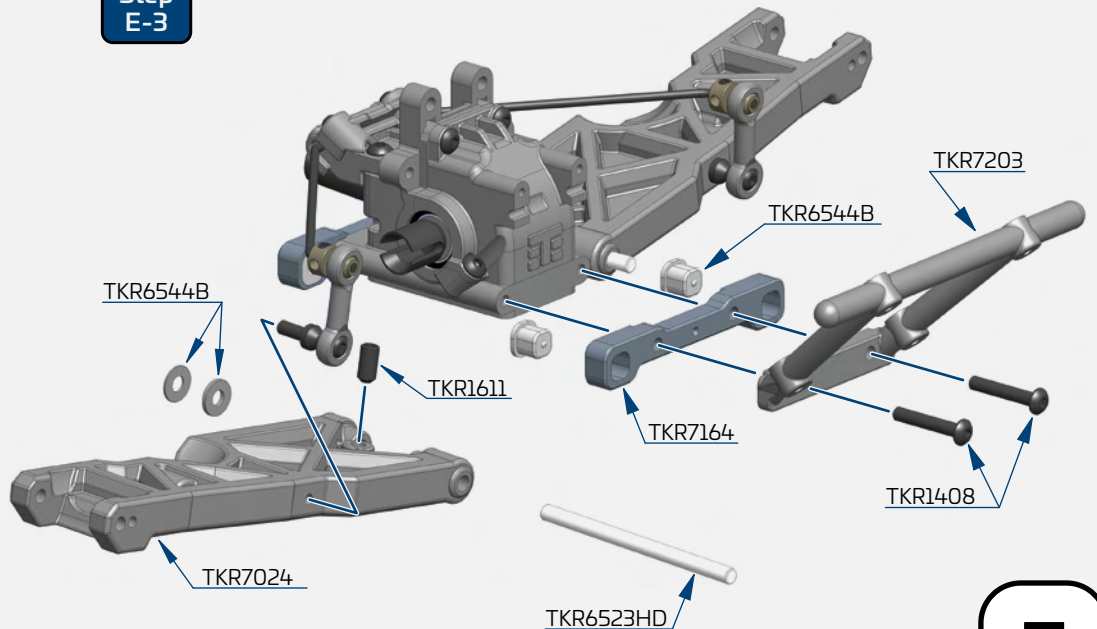

Bag F

Rear Hub/CVA Assembly

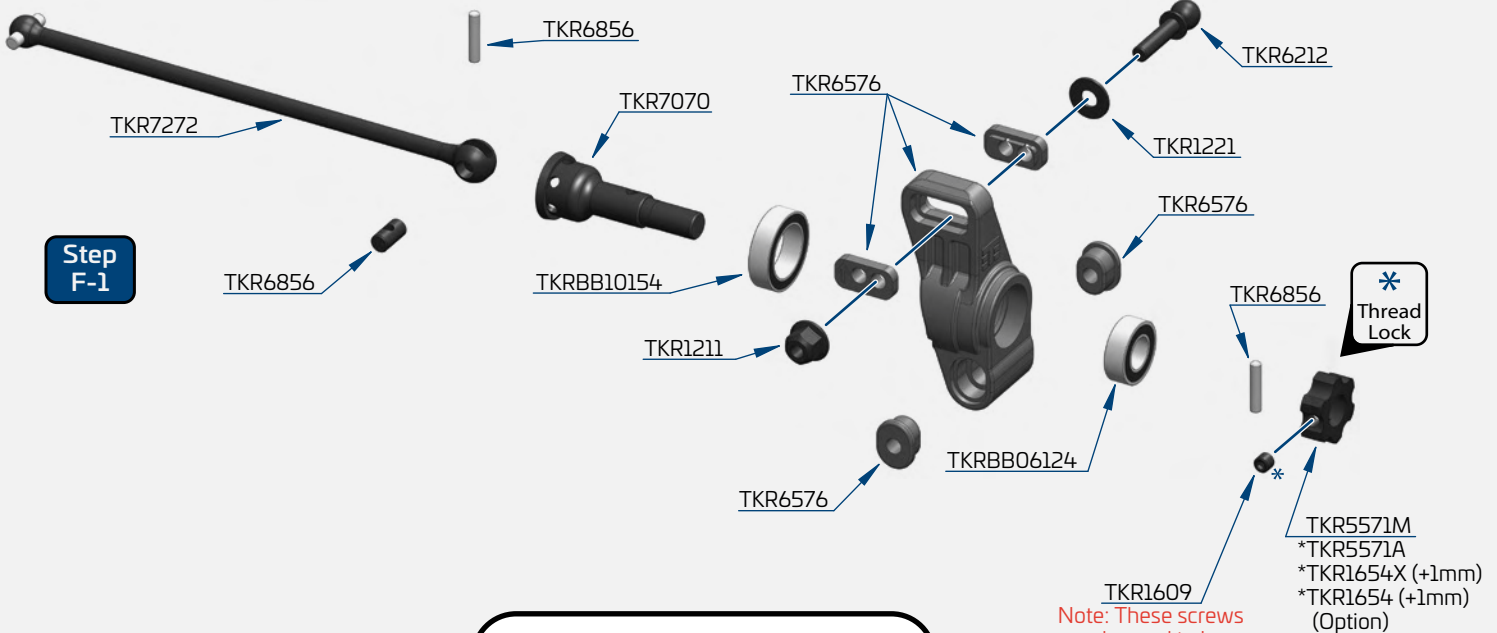

Note: These screws only need to be snug. Do not over-tighten.

HUB INSERTS

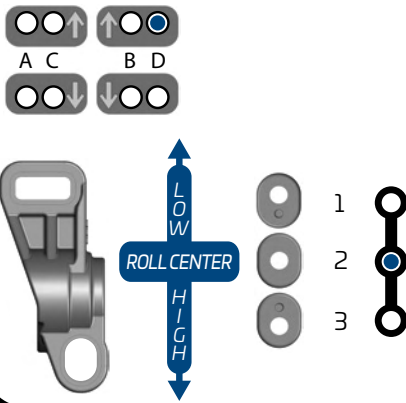

TOP VIEW HUB ORIENTATION

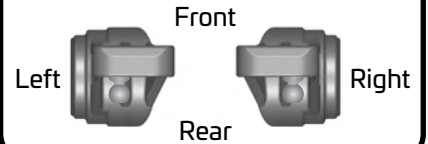

x2
TKR1211
M3 Lock Nut Flange Black

x2
TKR1221
M3x8mm Washer

x2
TKR1400
M3x4mm Button Head Screw

x2
TKR1609
M3x3mm Set Screw

x2
TKRBB06124
Ball Bearing (6x12x4)

x2
TKRBB10154
Ball Bearing (10x15x4)

x2
TKR6212
M3x12mm Ball Stud

Step F-2

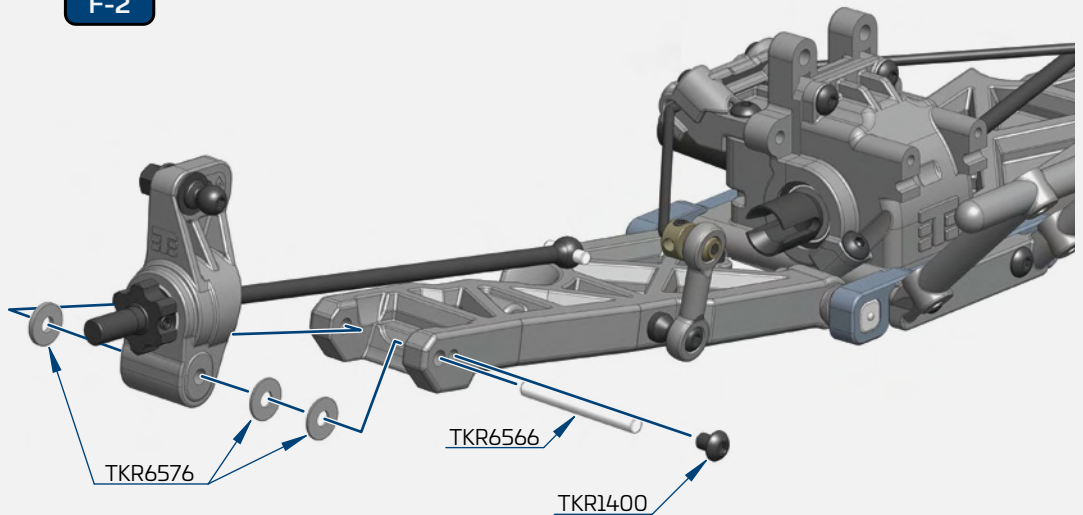

Note: These screws only need to be snug. Do not over-tighten.

Bag F

Rear Camber Links



Step F-3

Build Tip: Use some grease or Chapstick on the threads to help prevent "pop-off" when adjustments are being made.

Build Note: Hold the turnbuckle stationary with pliers and push the rod end hard onto the turnbuckle while turning at the same time. Keep in mind that one end of the turnbuckle has normal threads and the other has reverse threads. Start the rod end straight and it will thread on straight.

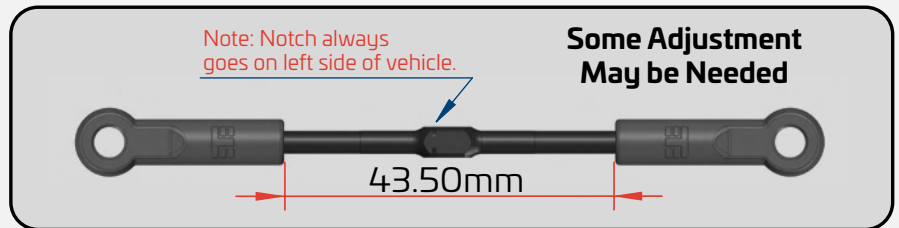

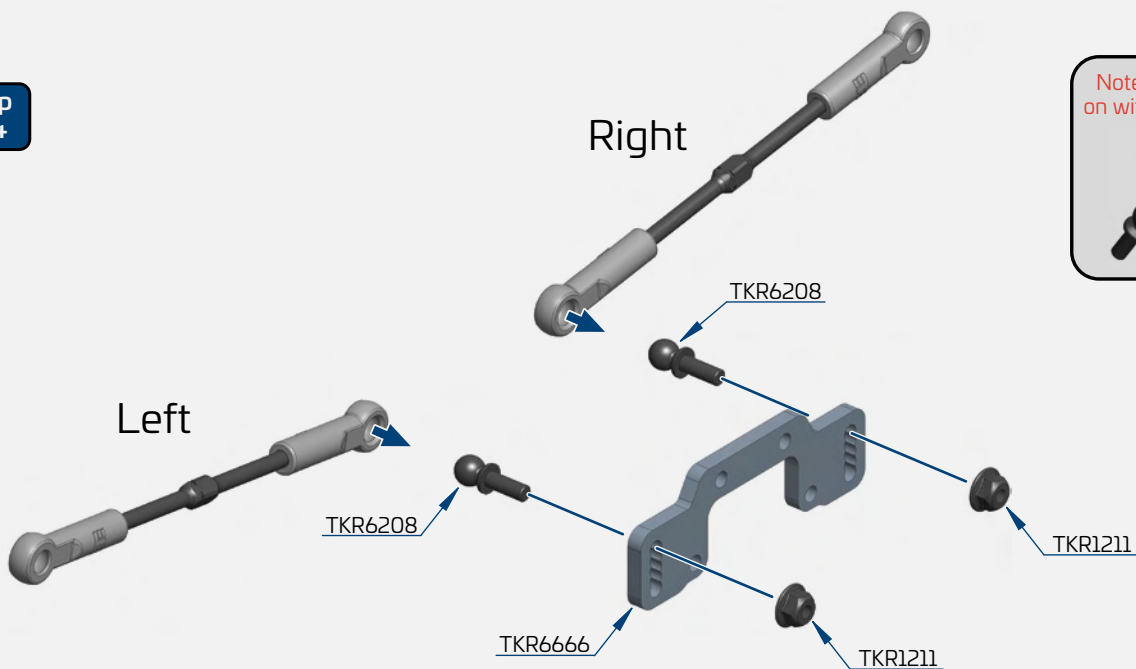

Step F-4

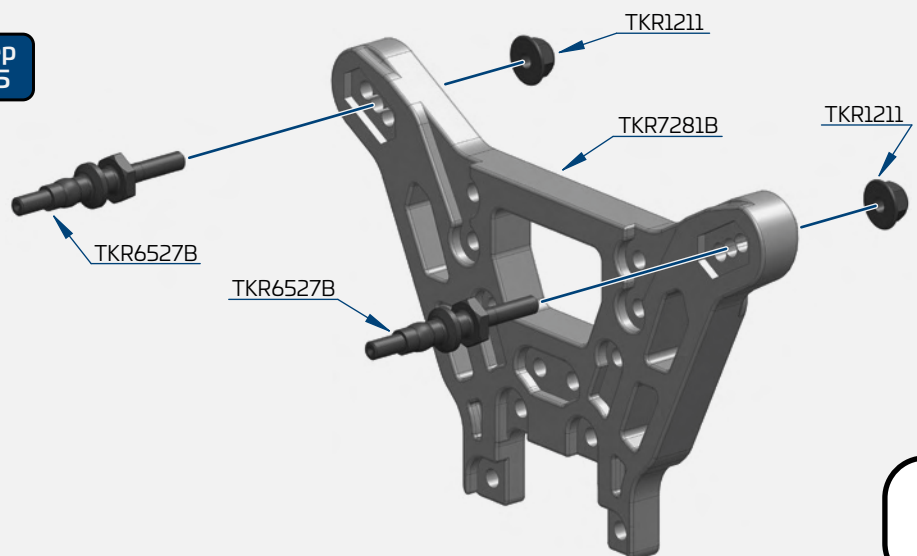

Step F-5



-  x4
TKR1211
M3 Lock Nut Flange Black
-  x2
TKR1405
M3x14mm Button Head Screw
-  x2
TKR6208
M3x8mm Ball Stud

Bag F

Rear Tower

Step
F-6

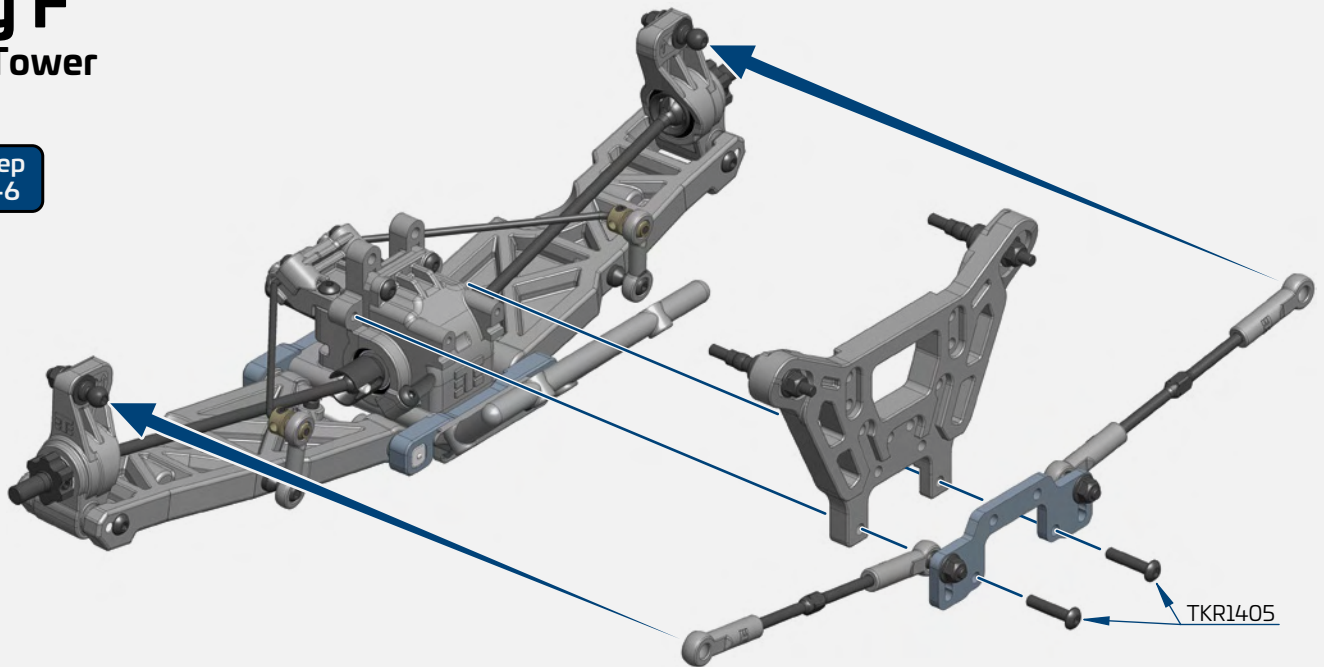

Step
F-7

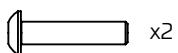
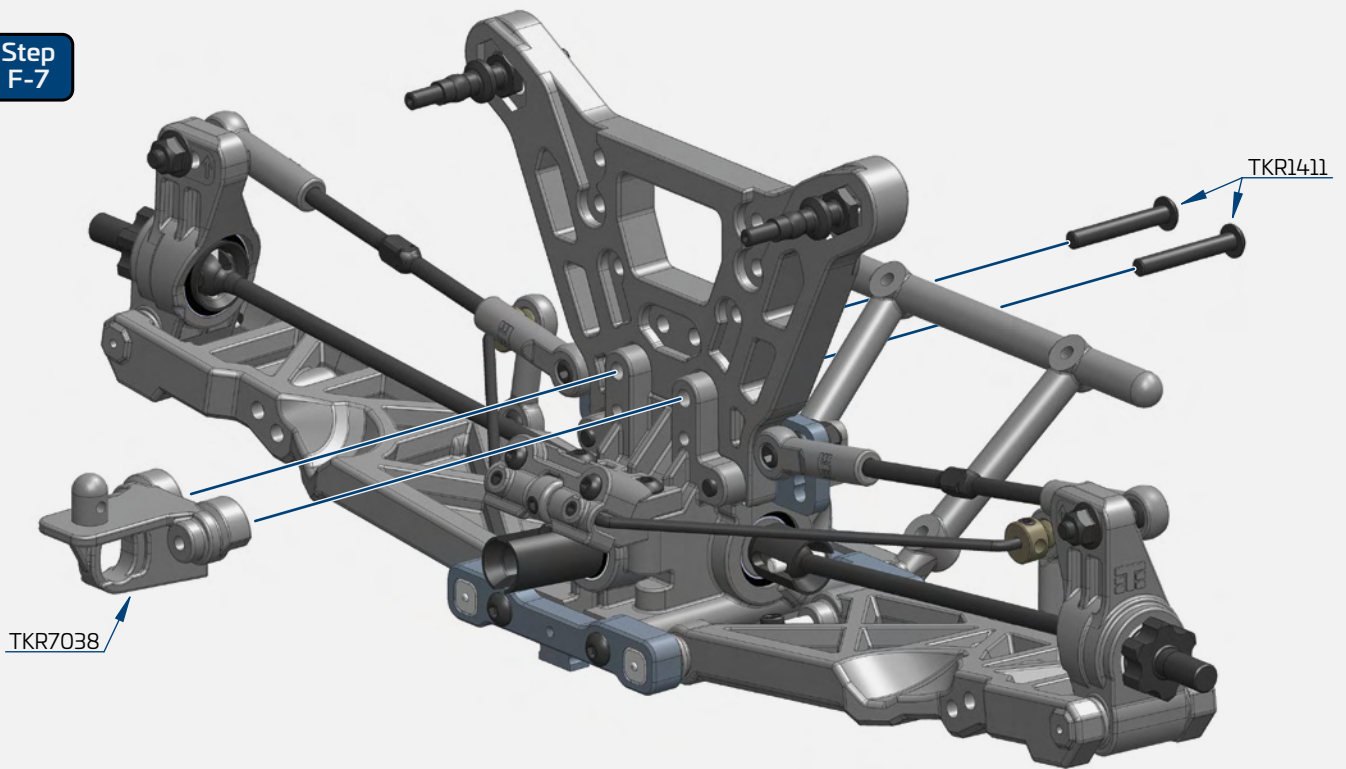

x2

TKR1405
M3x14mm Button Head Screw

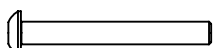

x2

TKR1411
M3x25mm Button Head Screw

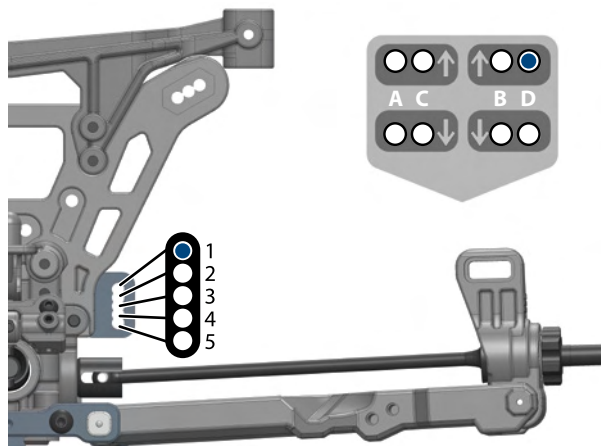

Stock position is 1/D

Bag G Front End Assembly

Step G-1

TKR6624 - 1.5mm
Below options sold separately.
*TKR6624 - 1.6mm
*TKR6624 - 1.7mm
*TKR6624 - 1.8mm
*TKR6624 - 1.9mm
(Option)

TKR1601
Note: Do not over-tighten.

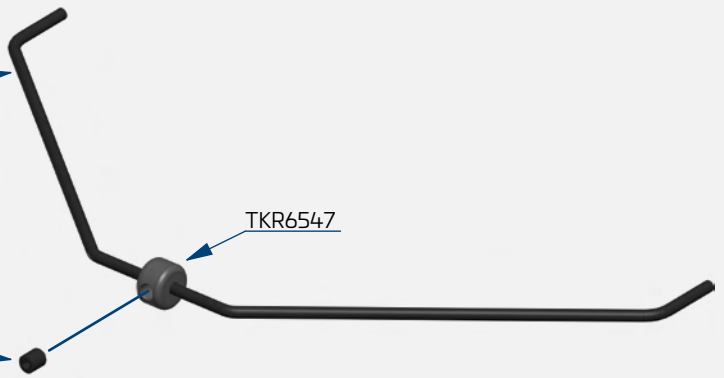

Step G-2

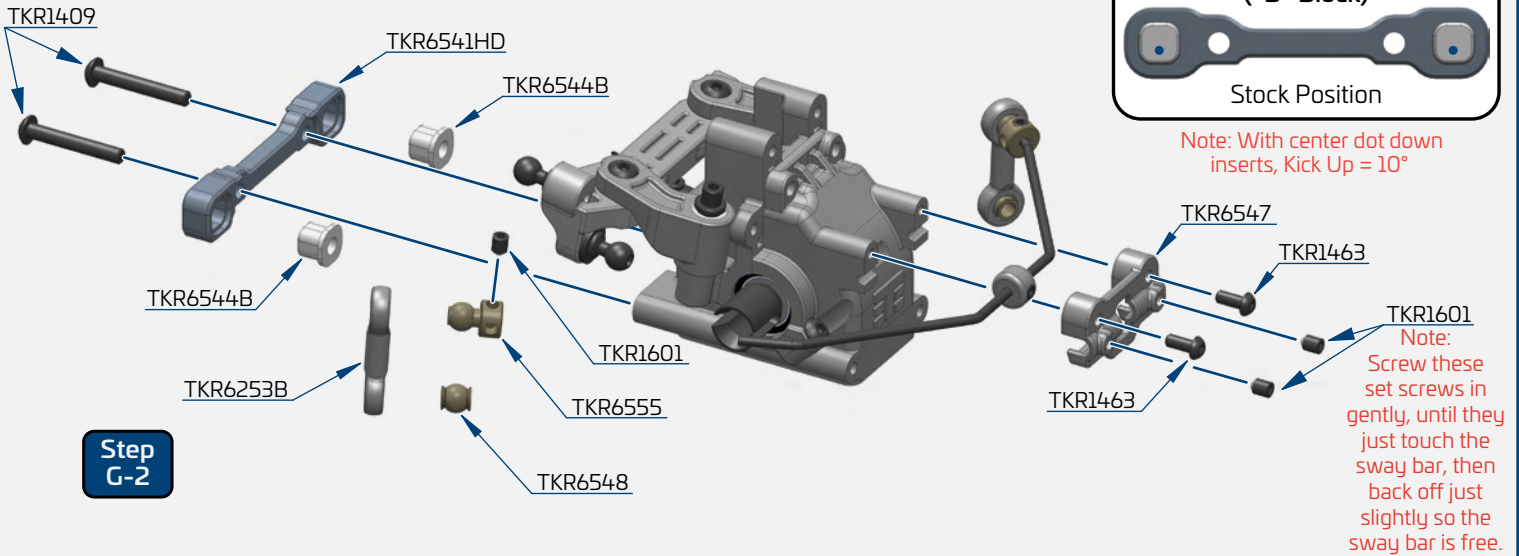

Step G-3

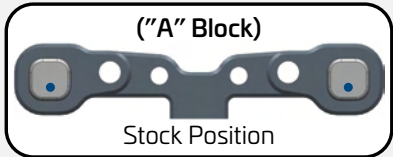

Note: With center dot down inserts, Arm Sweep = 0°

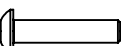
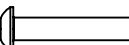
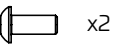
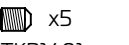
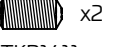

-  x2
TKR1405
M3x14mm Button Head Screw
-  x4
TKR1409
M3x20mm Button Head Screw
-  x2
TKR1463
M2.5x6mm Button Head Screw
-  x5
TKR1601
M3x4mm Set Screw
-  x2
TKR1611
M4x8mm Set Screw

Wheelbase Shims

front	2mm
	large 1mm
	small .5mm
rear	0mm

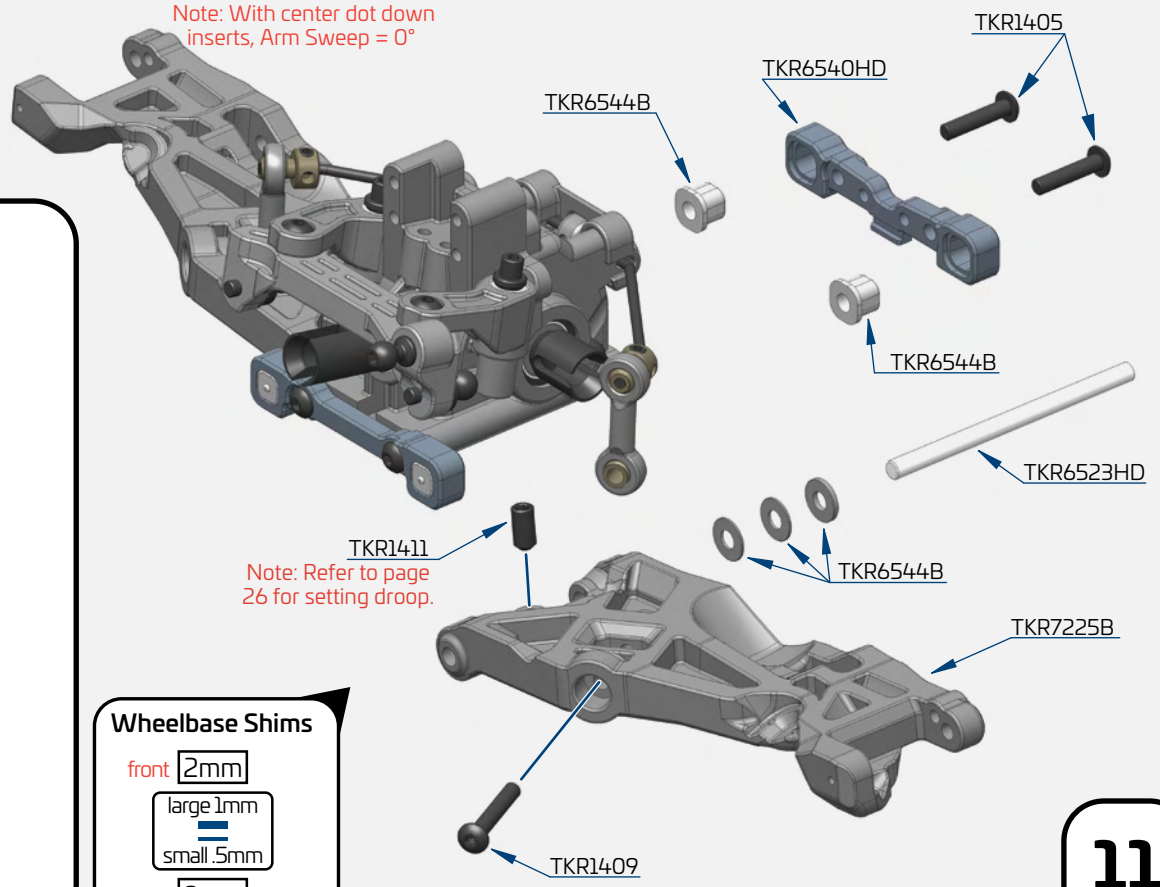

Bag H

Front Spindle/CVA Assembly

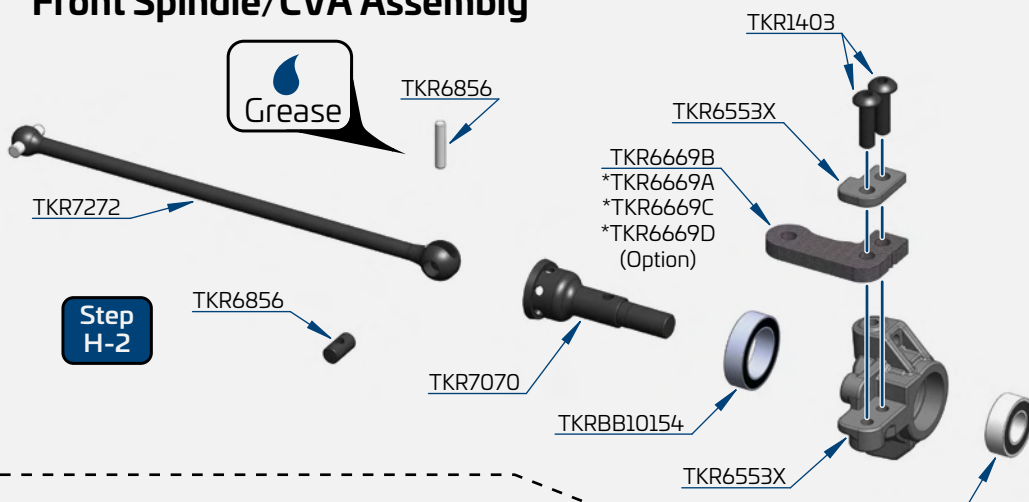

Step H-1

Note: These optional steering stop screws can help with erratic steering. They provide a mechanical limit to the steering throw and can make the car easier to drive. They are recommended in addition to limiting steering on your radio to match. Washers (TKR1221) can also be added for further control.



Step H-2

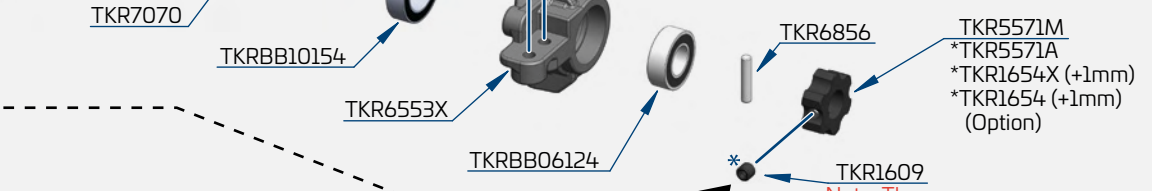

Step H-3

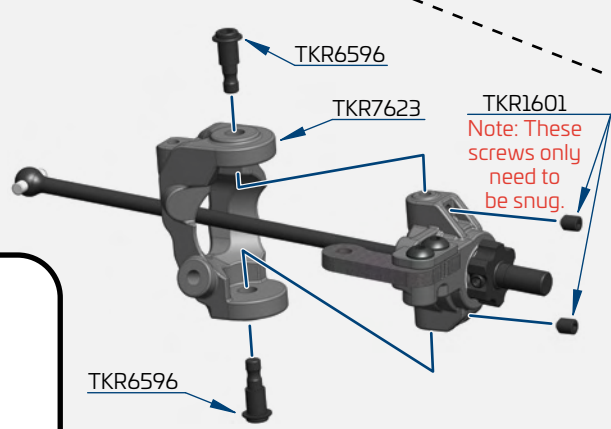

* Thread Lock

Note: These screws only need to be snug. Do not over-tighten.



Note: Pre-thread the kingpin screws into the spindles prior to installing them into the spindle carriers. This will ensure there will be no binding.

- x2
TKR1201
M3 Lock Nut Black
- x4
TKR1400
M3x4mm Button Head Screw
- x4
TKR1403
M3x10mm Button Head Screw
- x8
TKR1601
M3x4mm Set Screw
- x2
TKR1609
M3x3mm Set Screw

Step H-4

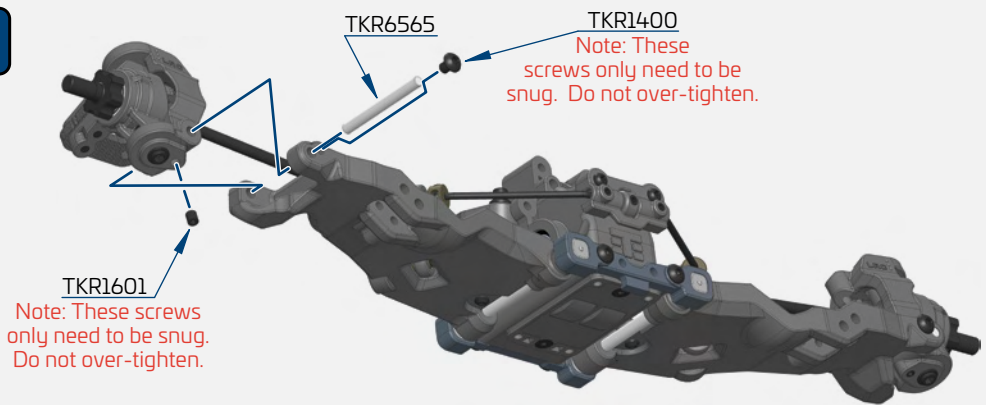

Note: These screws only need to be snug. Do not over-tighten.

Note: These screws only need to be snug. Do not over-tighten.

- x2
TKRBB06124
Ball Bearing (6x12x4)
- x2
TKRBB10154
Ball Bearing (10x15x4)
- x4
TKR6218
M3x8mm Ball Stud

Step H-5

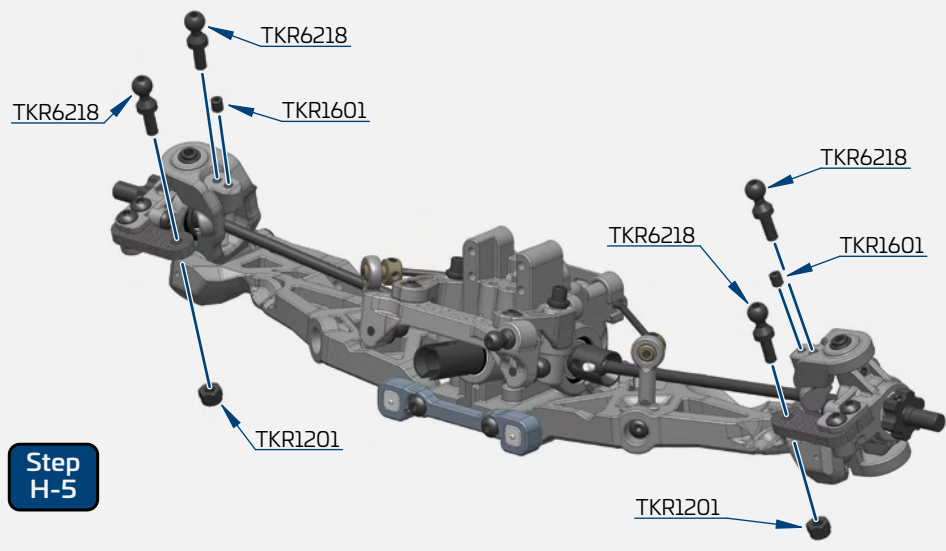

Bag I

Front Camber Links & Steering Links

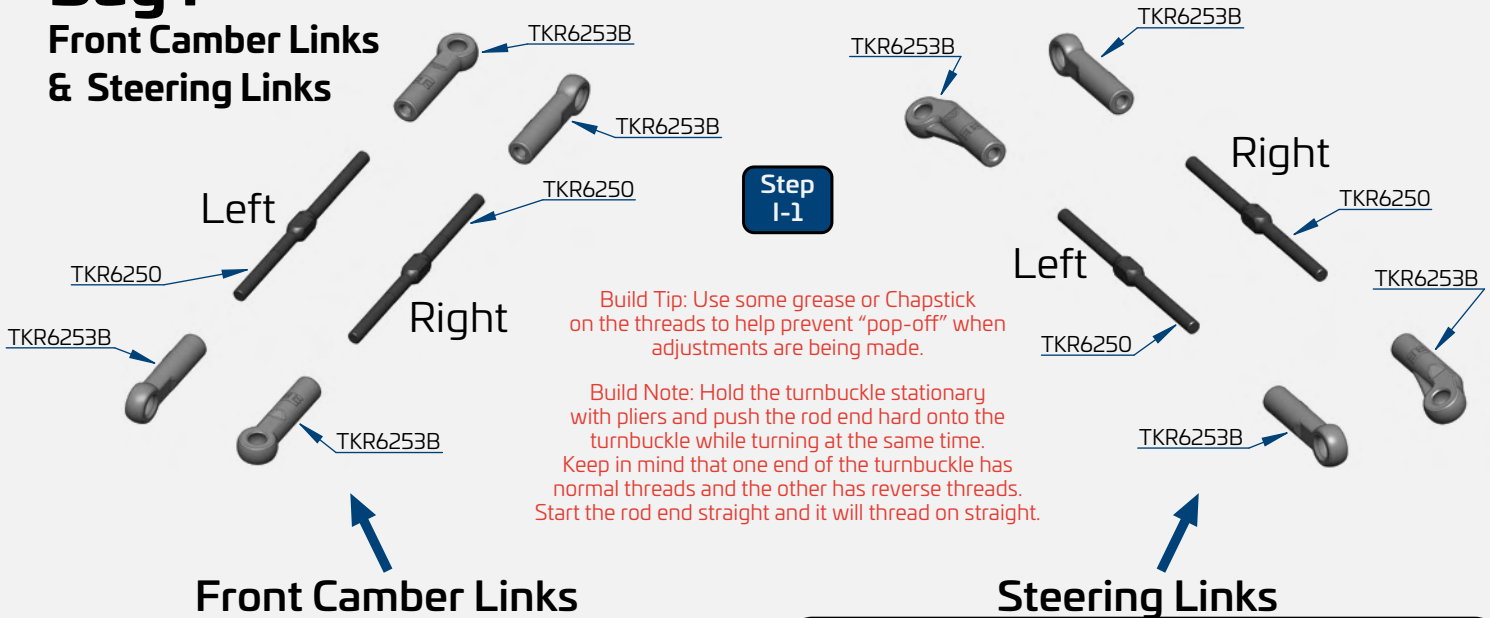

Build Tip: Use some grease or Chapstick on the threads to help prevent "pop-off" when adjustments are being made.

Build Note: Hold the turnbuckle stationary with pliers and push the rod end hard onto the turnbuckle while turning at the same time. Keep in mind that one end of the turnbuckle has normal threads and the other has reverse threads. Start the rod end straight and it will thread on straight.

Note: Notch always goes on left side of vehicle.

Some Adjustment May be Needed

32.25mm

Note: Notch always goes on left side of vehicle.

Some Adjustment May be Needed

34.00mm

Step I-2

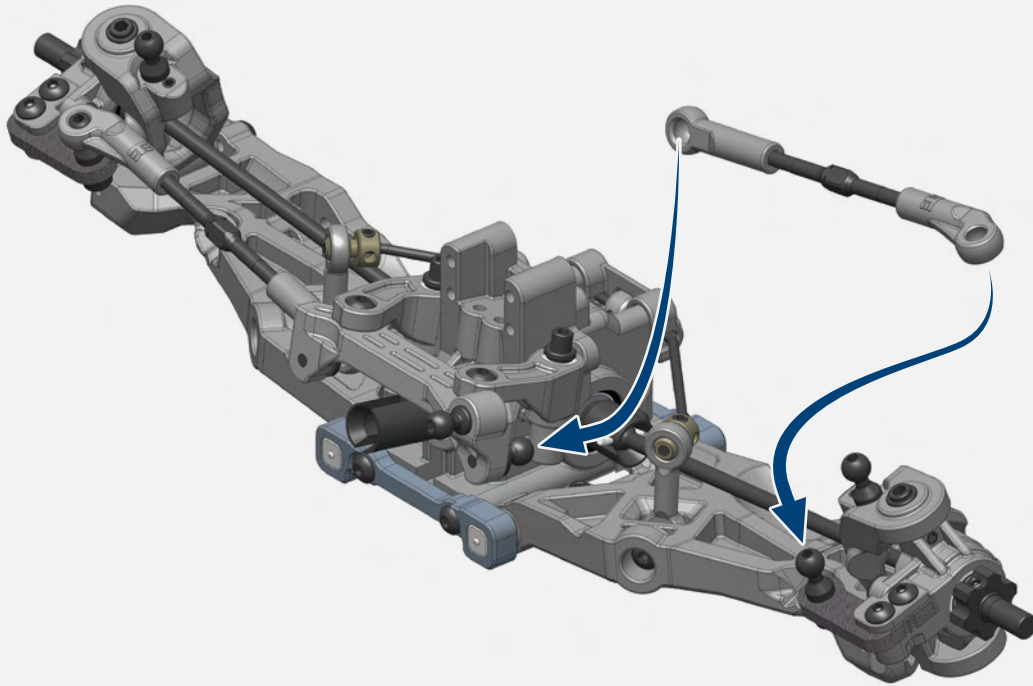

Note: Always press on with **T** logo visible.

Step I-3

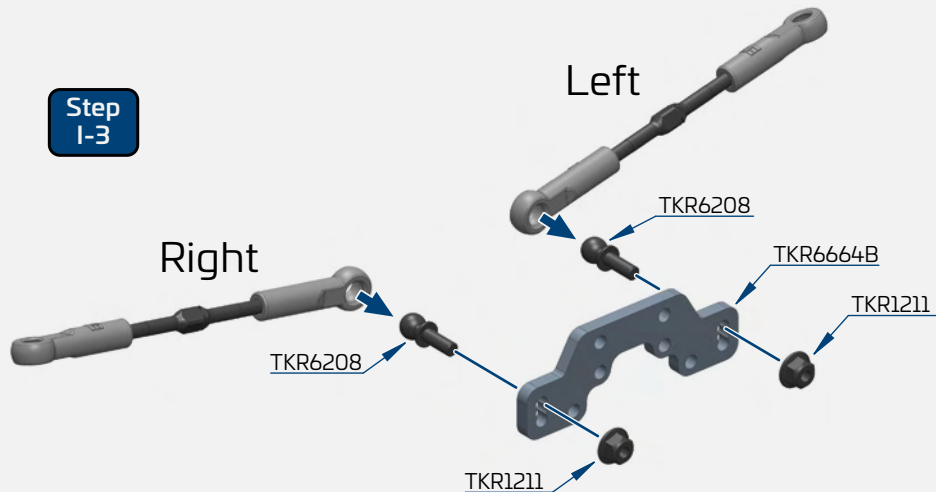

x2
TKR1211
M3 Lock Nut Flange Black

x2
TKR6208
M3x8mm Ball Stud

Bag I

Front Camber Plate/Tower

Step
I-4

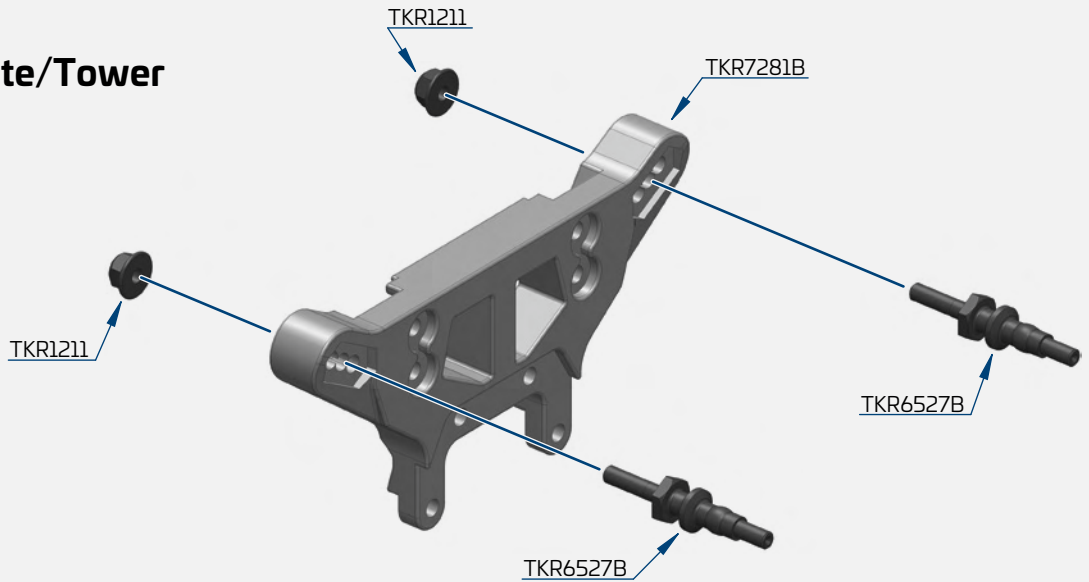

Step
I-5

Note: Always press on with **T** logo visible.

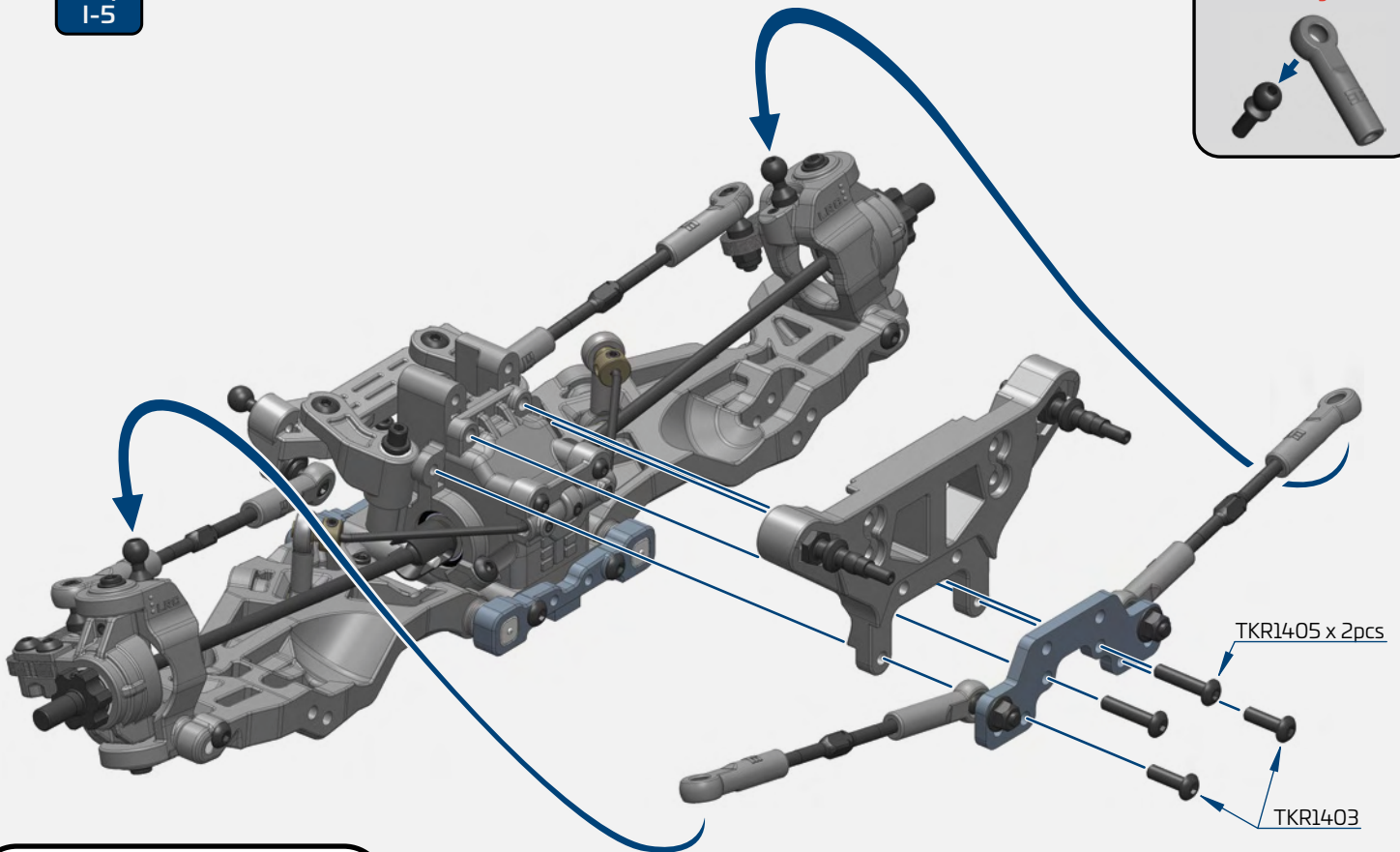

x2
TKR1211
M3 Lock Nut Flange Black

x2
TKR1403
M3x10mm Button Head Screw

x2
TKR1405
M3x14mm Button Head Screw

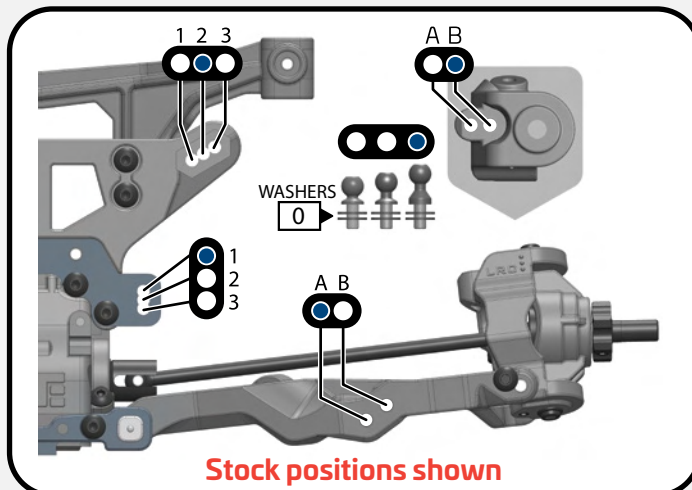

Stock positions shown

Bag J

Front/Center Assembly

Step J-1

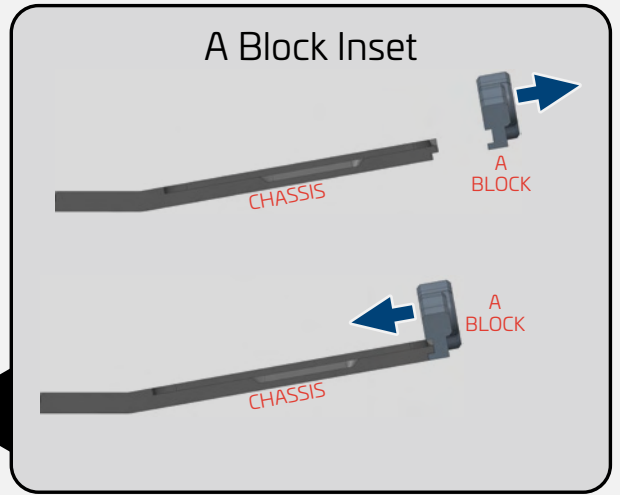
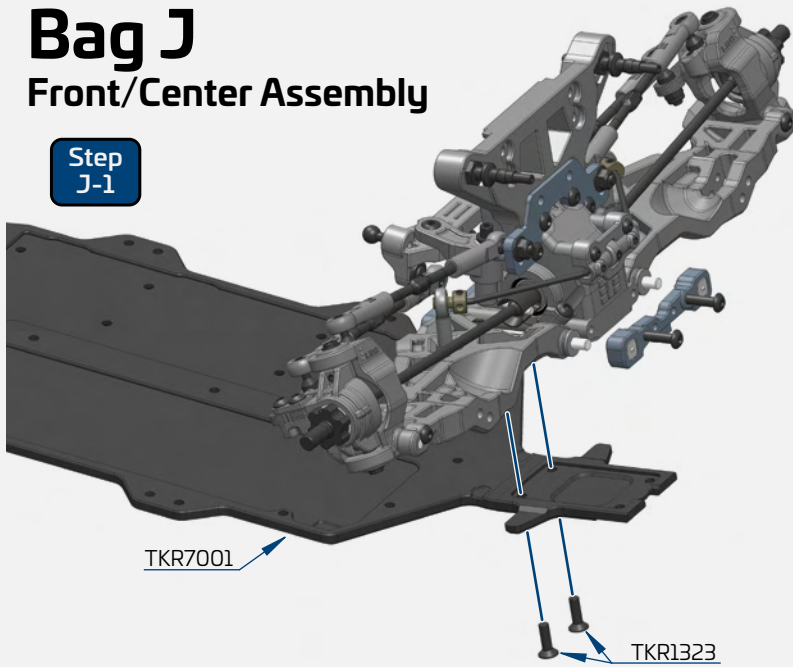

Note: It is necessary to slightly loosen both screws holding the A block in place before attaching the front clip to the chassis. This is due to the fact that the A block is now keyed into the front of the chassis. This feature helps secure the front clip and improves durability.

Step J-2

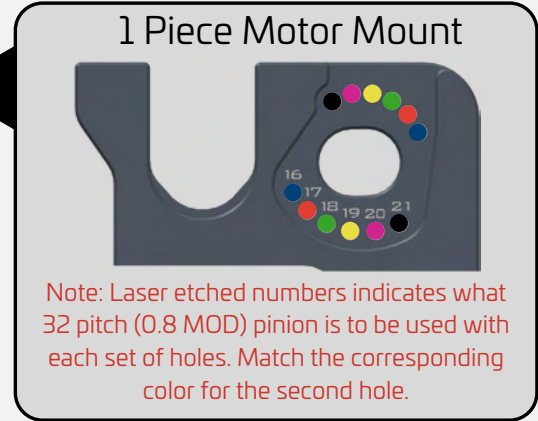
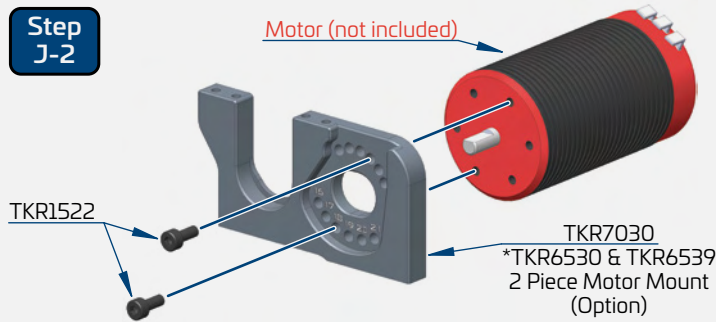

Note: Laser etched numbers indicates what 32 pitch (0.8 MOD) pinion is to be used with each set of holes. Match the corresponding color for the second hole.

Step J-3

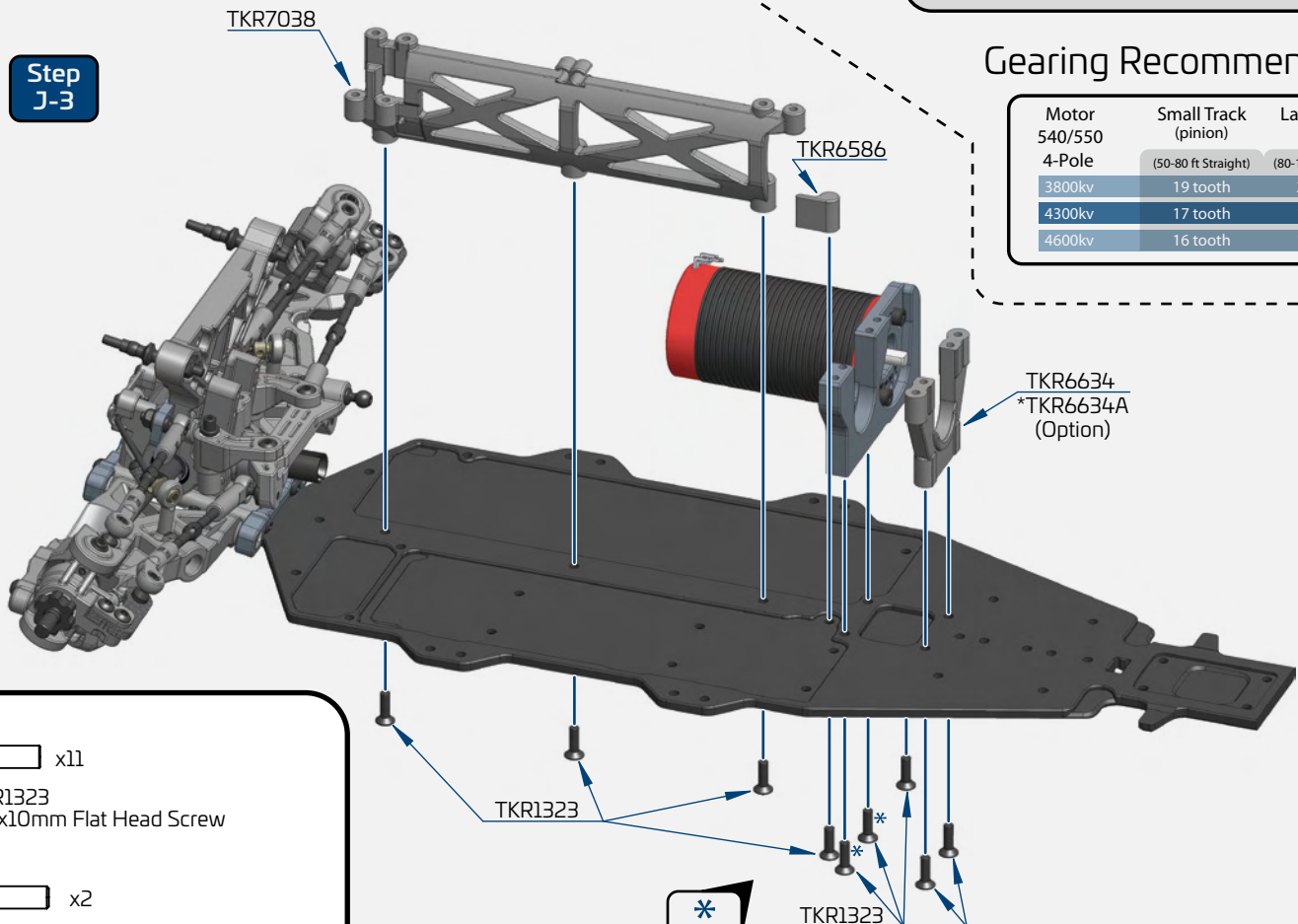

Gearing Recommendations

Motor 540/550 4-Pole	Small Track (pinion)	Large Track (pinion)
	(50-80 ft Straight)	(80-150 ft Straight)
3800kv	19 tooth	21 tooth
4300kv	17 tooth	19 tooth
4600kv	16 tooth	18 tooth

x11
TKR1323
M3x10mm Flat Head Screw

x2
TKR1522
M3x8mm Cap Head Screw

*
Thread Lock

Bag J Center/Rear Assembly

Step
J-4



Step
J-5

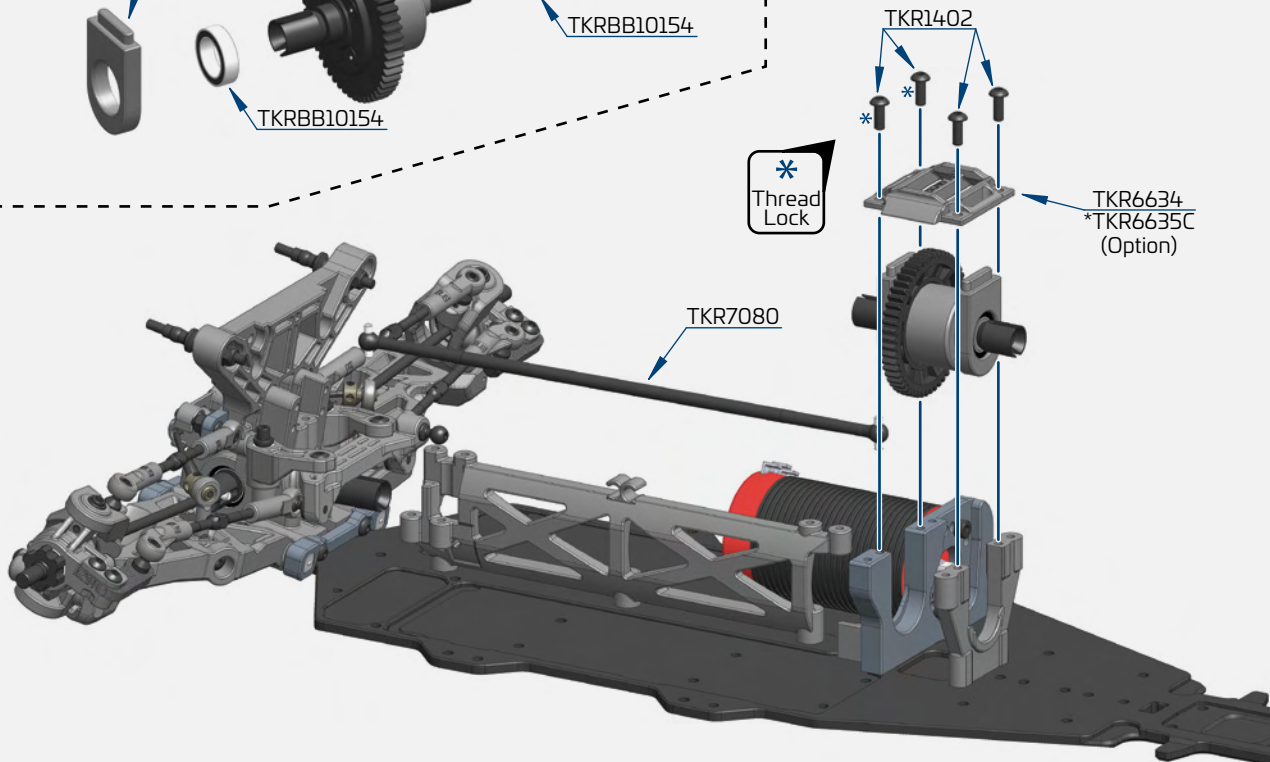

Step
J-6

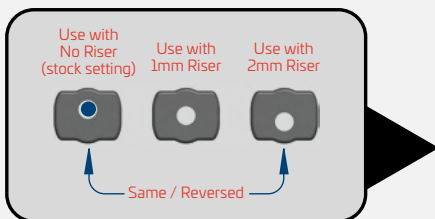

Note: Use just the long brace for less flex or just the short brace for the most flex. More flex is best suited for bumpy tracks. The short brace can be found in BAG Q.

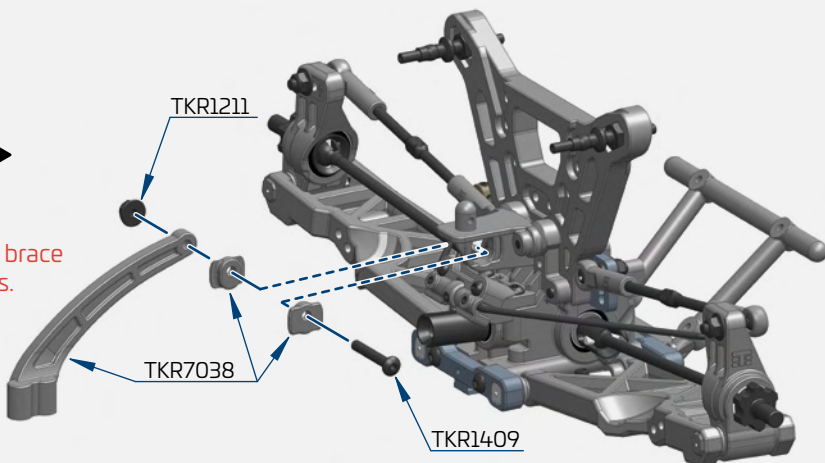

Step
J-7

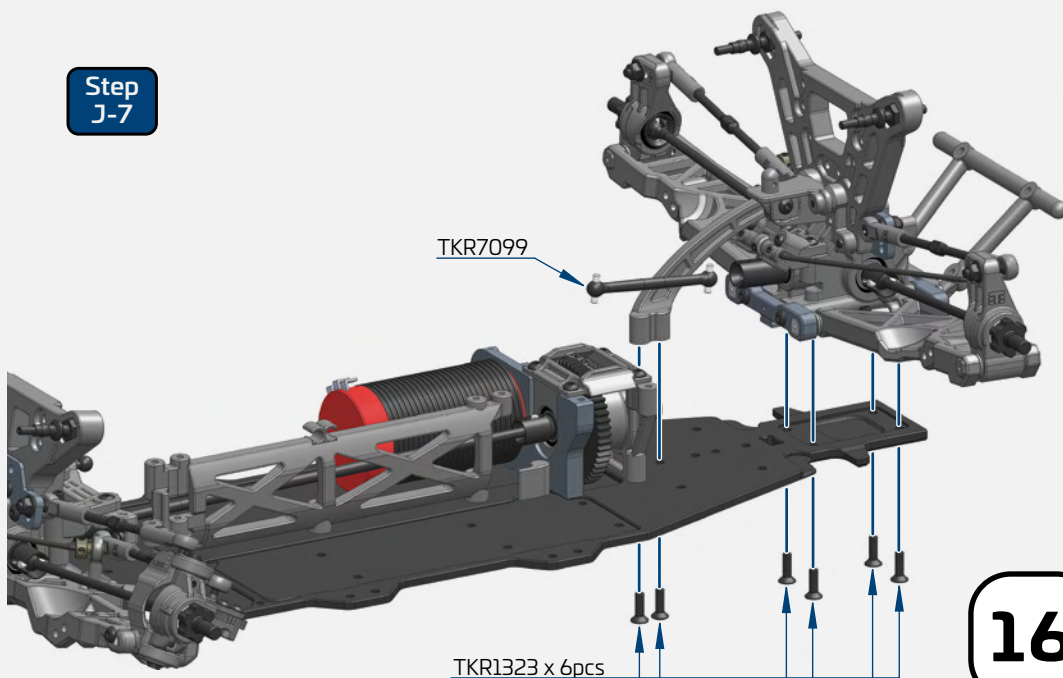

x1
TKR1211
M3 Lock Nut Flange Black

x6
TKR1323
M3x10mm Flat Head Screw

x4
TKR1402
M3x8mm Button Head Screw

x1
TKR1409
M3x20mm Button Head Screw

x2

TKRBB10154
Ball Bearing (10x15x4)

TKR1323 x 6pcs

Bag K Front Shock Assembly

Step K-1

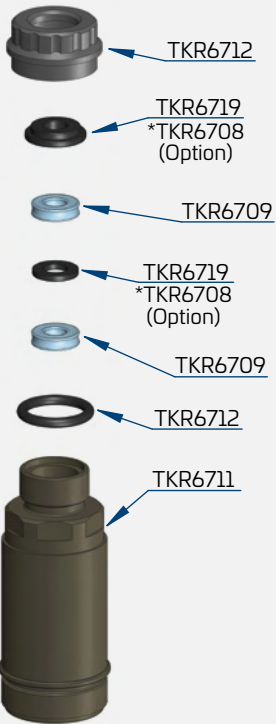
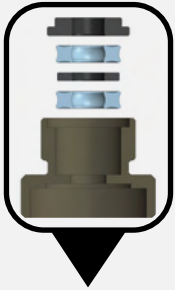

Step K-2

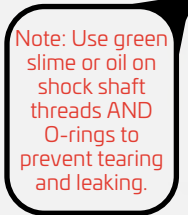

Step K-3

Refer to filling instructions on page 19 during this step.

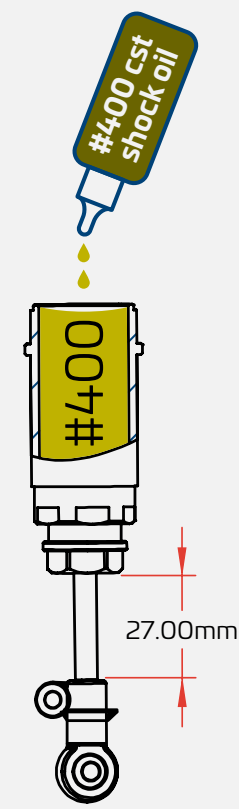

Note: Screw rod end on until distance measures 27mm at full extension.

Step K-4

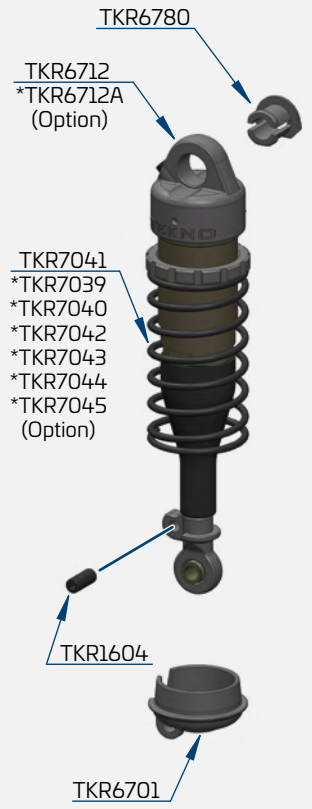

x2
TKR1211
M3 Lock Nut Flange Black

x2
TKR1240
M3x18mm Shock Mnt Screw

x2
TKR1245
M2x5mm Piston Screw

x2
TKR1248
M2x4mm Emulsion Screw

x2
TKR1604
M3x8mm Set Screw

Step K-5

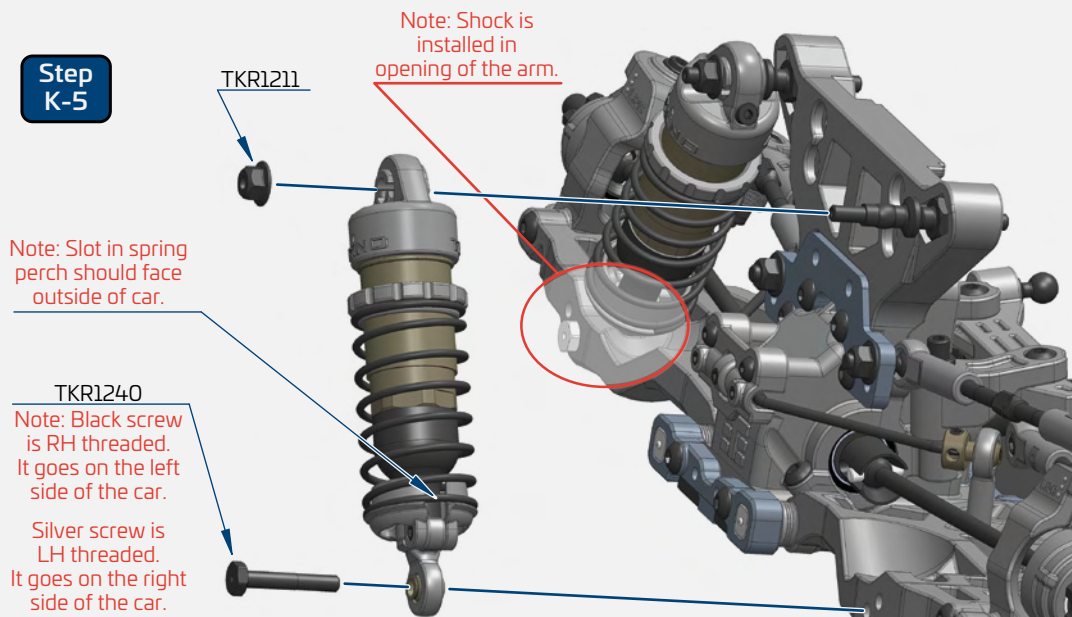

● Stock shock position is middle hole on the tower and inside hole on the arm (2/B)

● Shock length (droop) is 85mm
● Stock front ride height is 20mm

Bag L Rear Shock Assembly

Step L-1

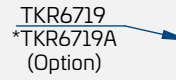
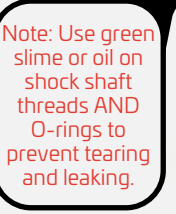
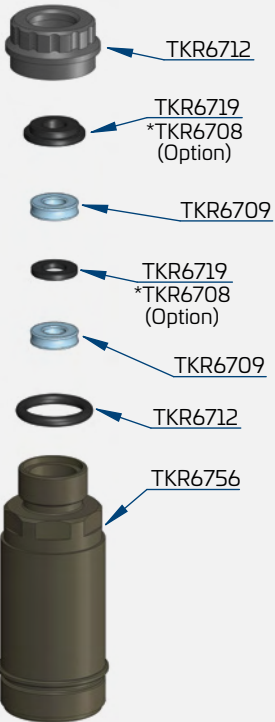
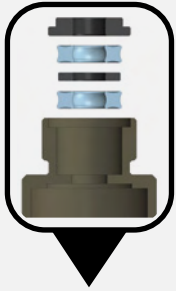

Step L-2

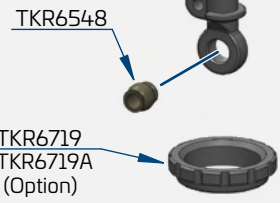
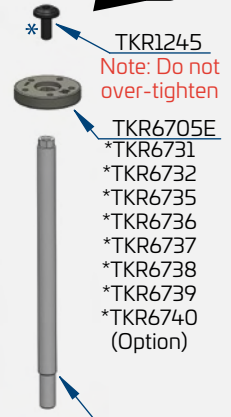

Step L-3

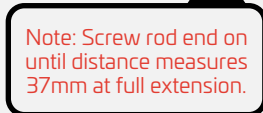
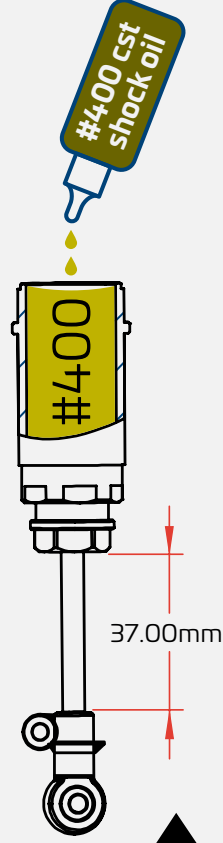

Step L-4

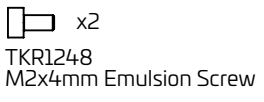
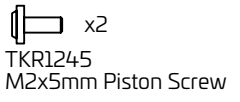
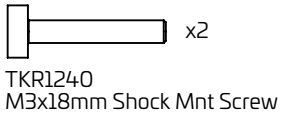
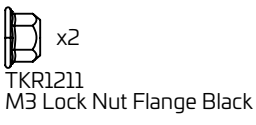
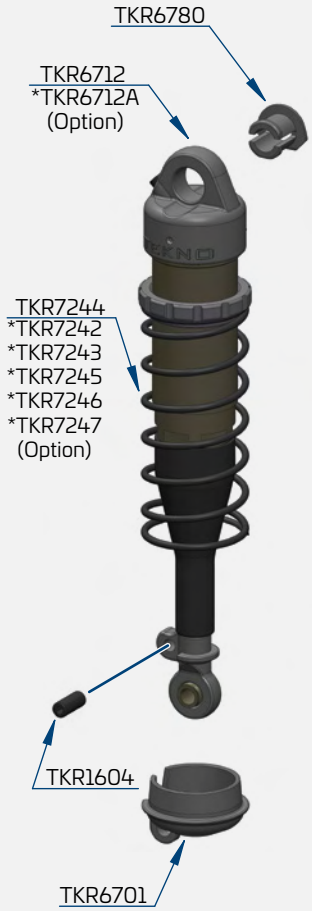

Step L-5

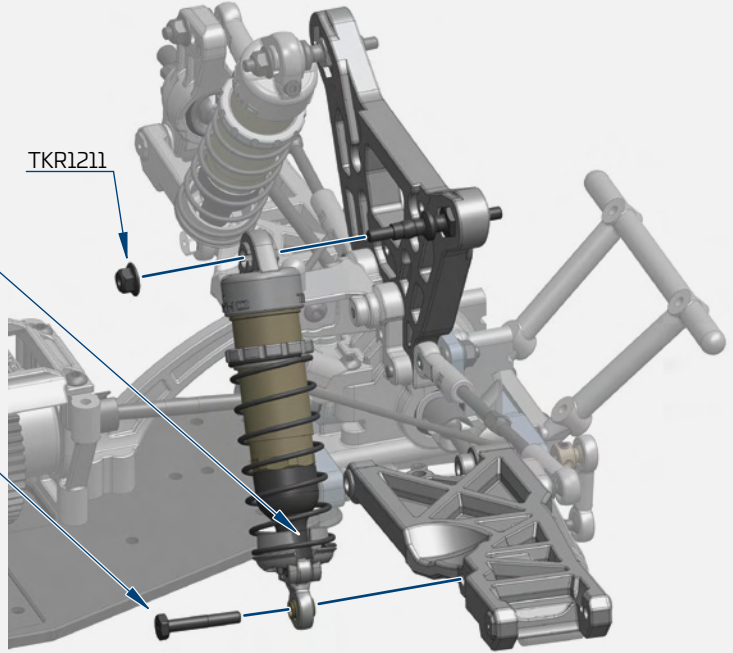

- Stock shock position is middle hole on the tower and inside hole on the arm.
- Shock length (droop) is 103mm
- Stock rear ride height is 20mm

Shock Filling Instructions

For both front and rear shocks

We've found it's easiest to complete steps 1 & 2 on each shock before moving on to step 3. By the time you've finished step 2 on the last shock, the first one will be ready for step 3.

Step 1. Start by drilling out the emulsion hole if necessary. Use a 1/16th (or 1.6mm) drill bit to drill all the way through and clear any flashing created by this. Insert the four larger o-rings into the emulsion caps and set aside. Install the small o-rings onto the small emulsion screws (TKR1248).

Step 2. Fill shock with oil all the way to the top and pump the shock shaft up and down 3-5 times.

Step 3. Screw on the cap all the way tight (shock tool TKR1115 is helpful for holding the shock body). Be careful to not cross-thread the caps. Start by turning in the opposite direction before tightening.

Step 4. With the shock at about a 45° angle, push and hold the shock shaft to the top of the stroke. Oil should leak out during this process. If it does not, remove the shock cap and add more oil before continuing. Insert the prepared emulsion screw/seal. Tighten the screw until snug (do not over-tighten). Wipe off excess oil before moving on to step 5.

Step 5. Pump the shock shaft up and down about 20 times vigorously. This emulsifies the oil.

Step 6. With the shock shaft fully extended, remove the emulsion screw from the cap to do the final bleed.

Step 7. With the shock at about a 45° angle, push and hold the shock shaft to the top and insert the prepared emulsion screw/seal again. Oil will leak out during this process. Finish by tightening the screw until snug (do not over-tighten).

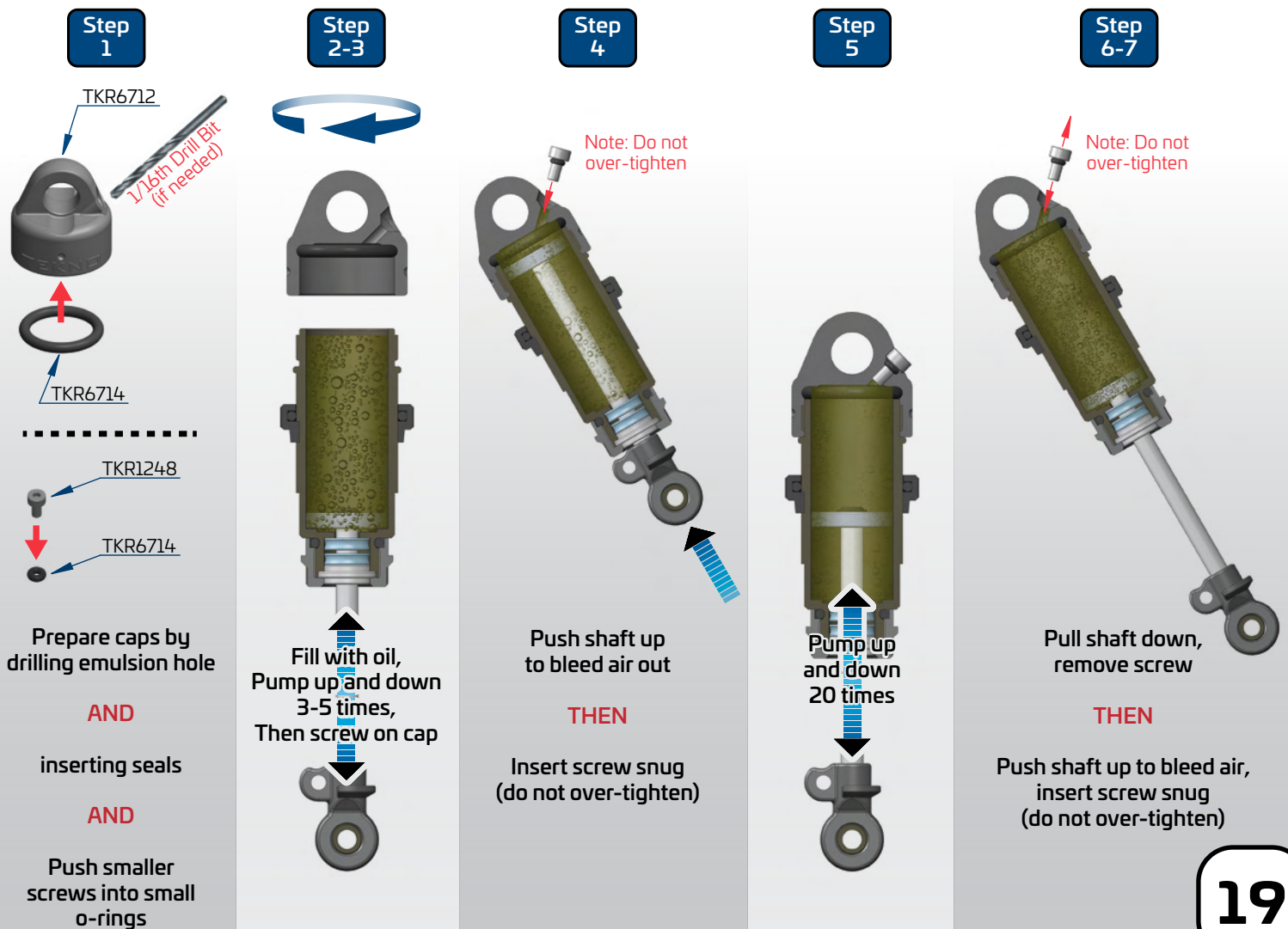

Bag M

Final Assembly

Step M-1

IMPORTANT RADIO SETUP TIPS, MUST READ:

The Tekno RC SCT410SL is highly tunable, but can be very aggressive depending on track conditions and tires used. To help with this, we recommend that you are well informed about setting up your Steering EPA, Servo Speed, Dual Rate, and Exponential Curves.

PLEASE READ PAGE 27 FOR MORE DETAILS.

Steering servo (not included)
 Note: We recommend using a full size servo with at least 240 oz/in torque and metal gears. Running less than our recommended rating will increase the chance of premature servo failure.

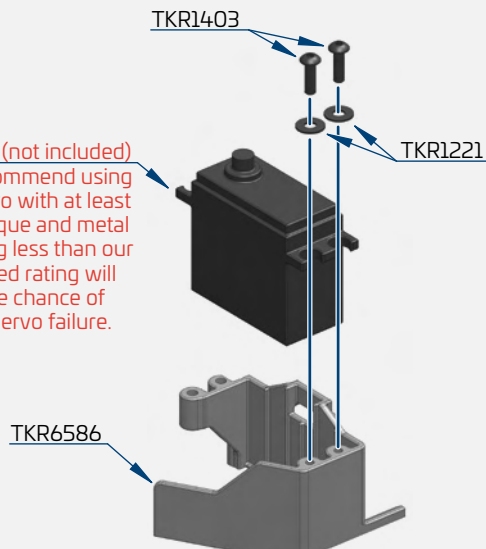

Step M-2

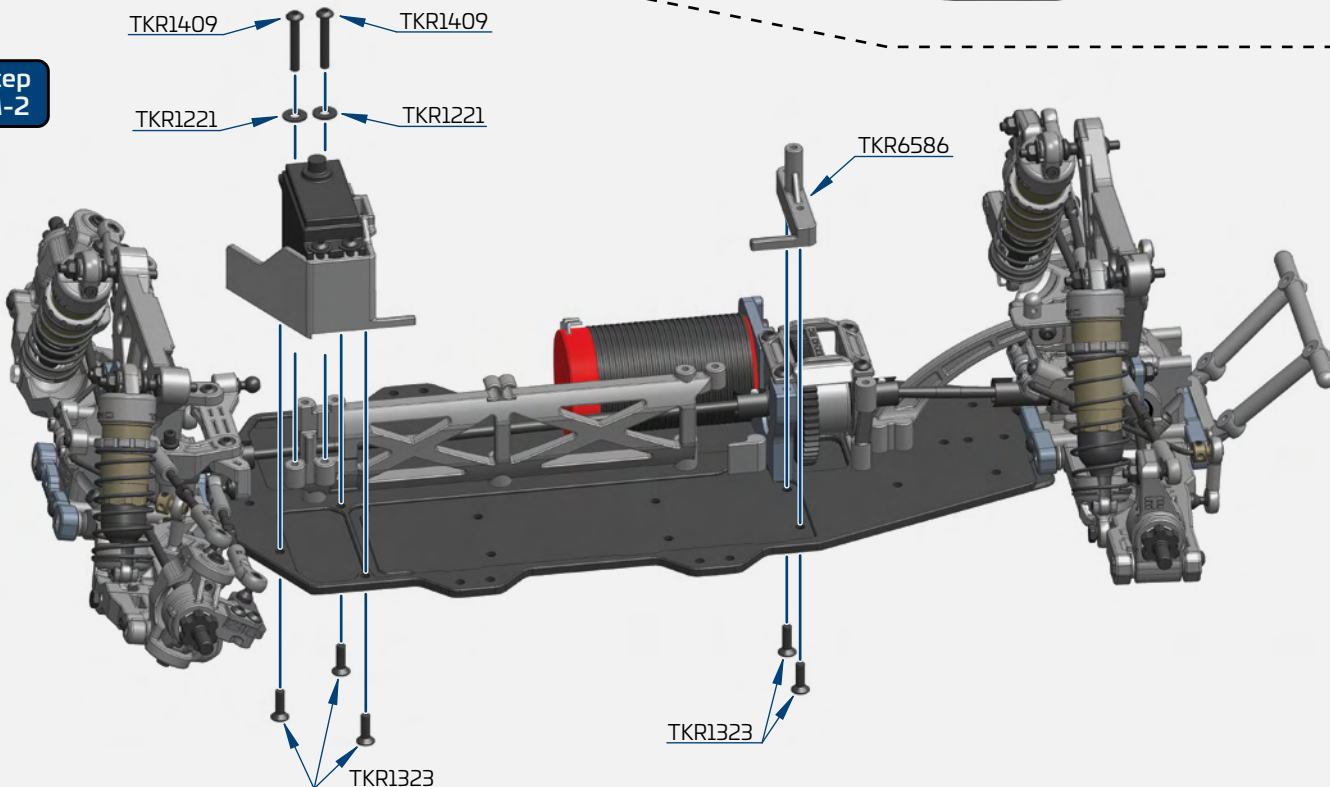

Step M-3

 x4
 TKR1221
 M3X8mm Washer

 x5
 TKR1323
 M3x10mm Flat Head Screw

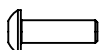
 x2
 TKR1403
 M3x10mm Button Head Screw

 x2
 TKR1409
 M3x20mm Button Head Screw

 Thread Lock

 *
 Attach pinion gear during this step. (not included)

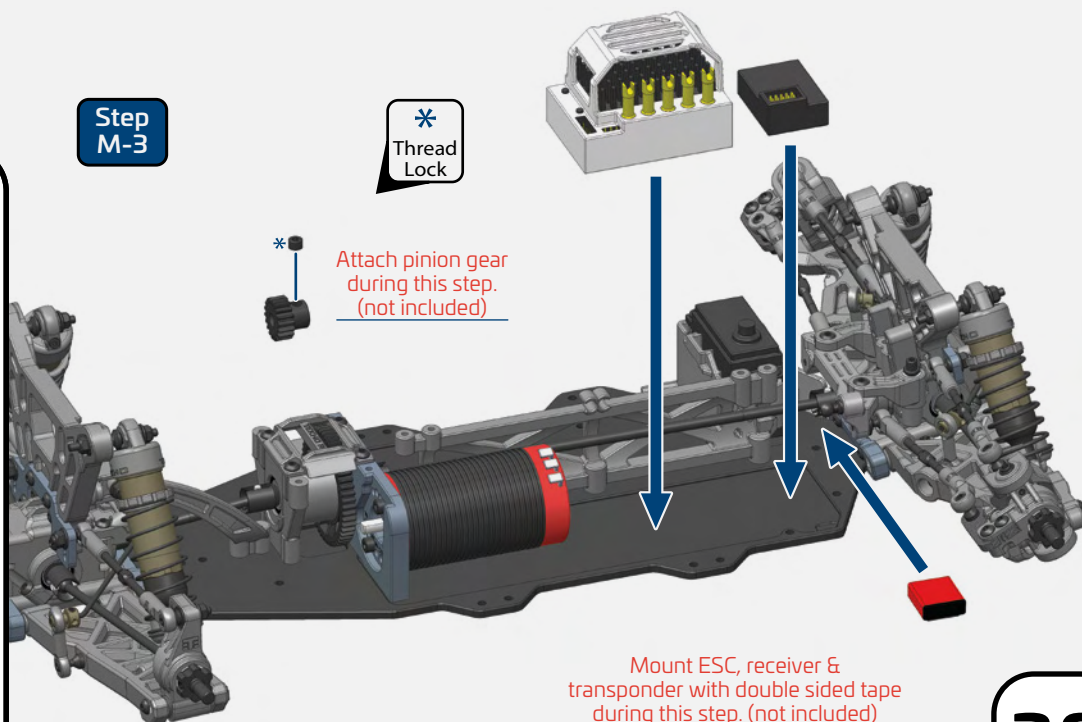

Mount ESC, receiver & transponder with double sided tape during this step. (not included)

Bag M

Final Assembly

Step M-4

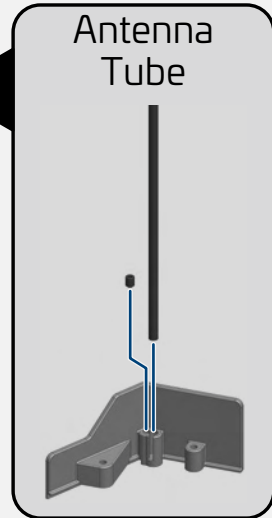
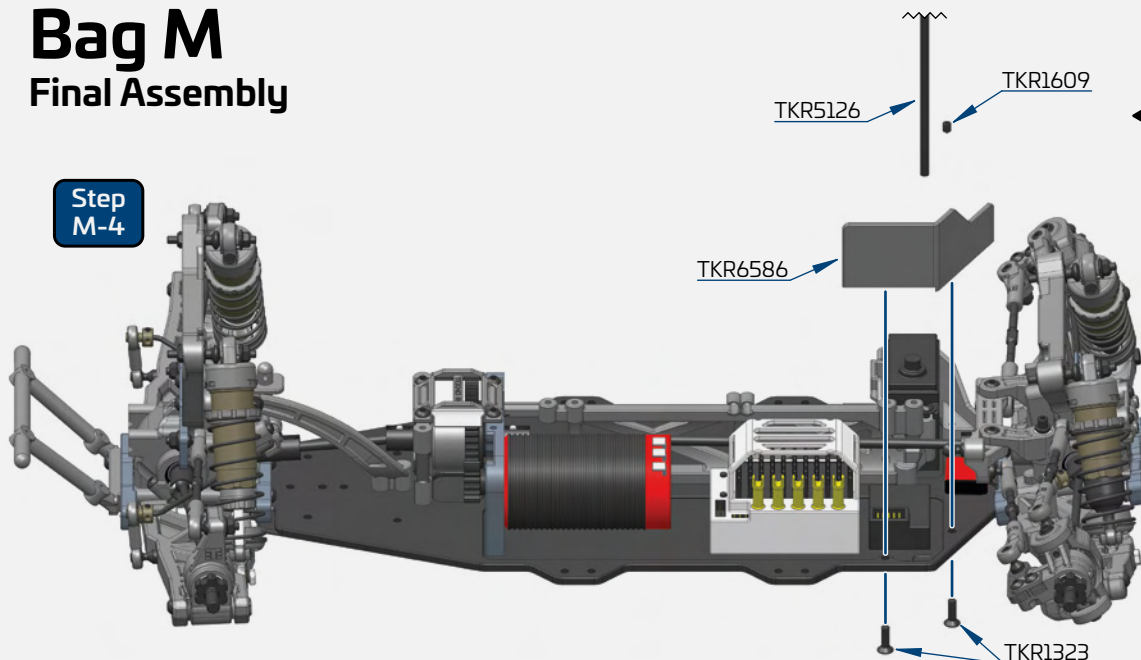

Step M-5



Step M-6

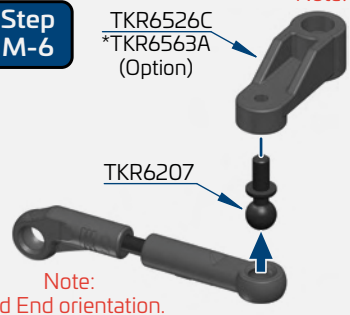

Step M-7

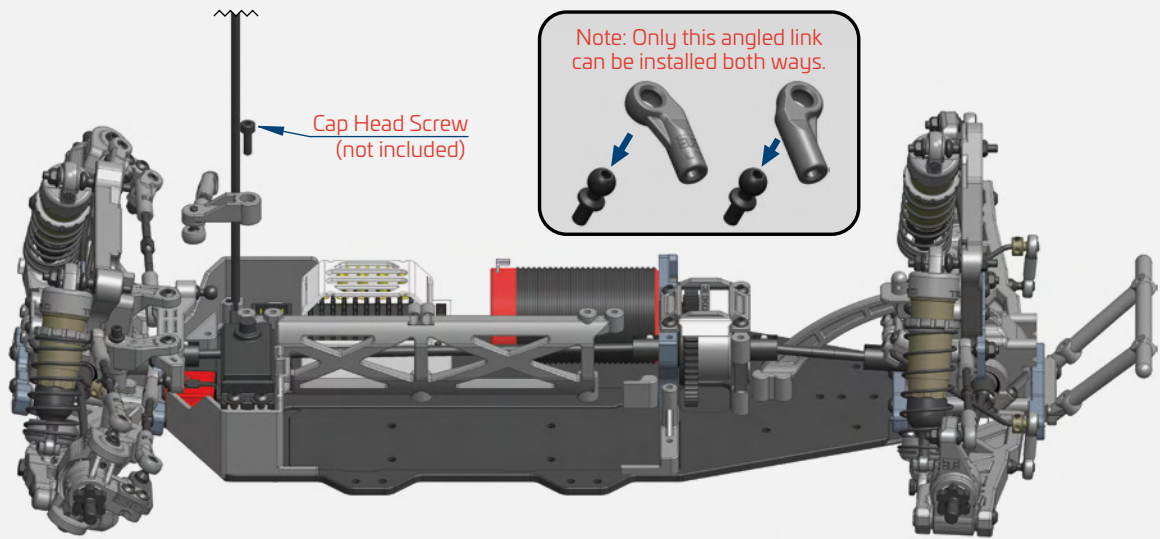

- x1
TKR1601
M3x4mm Set Screw
- x2
TKR1323
M3x10mm Flat Head Screw
- x1
TKR5238
M3x30 Threaded Rod
- x1
TKR6207
M3x6mm Ball Stud

Step M-8

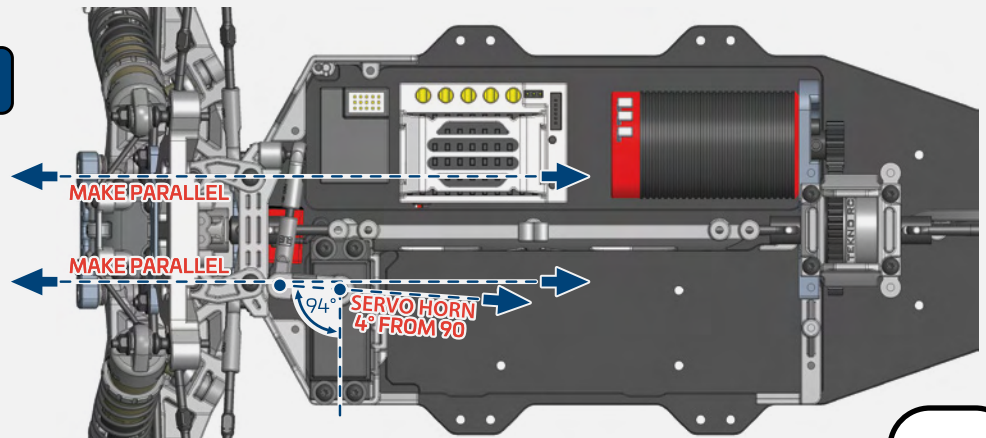



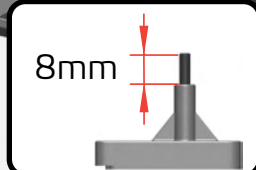
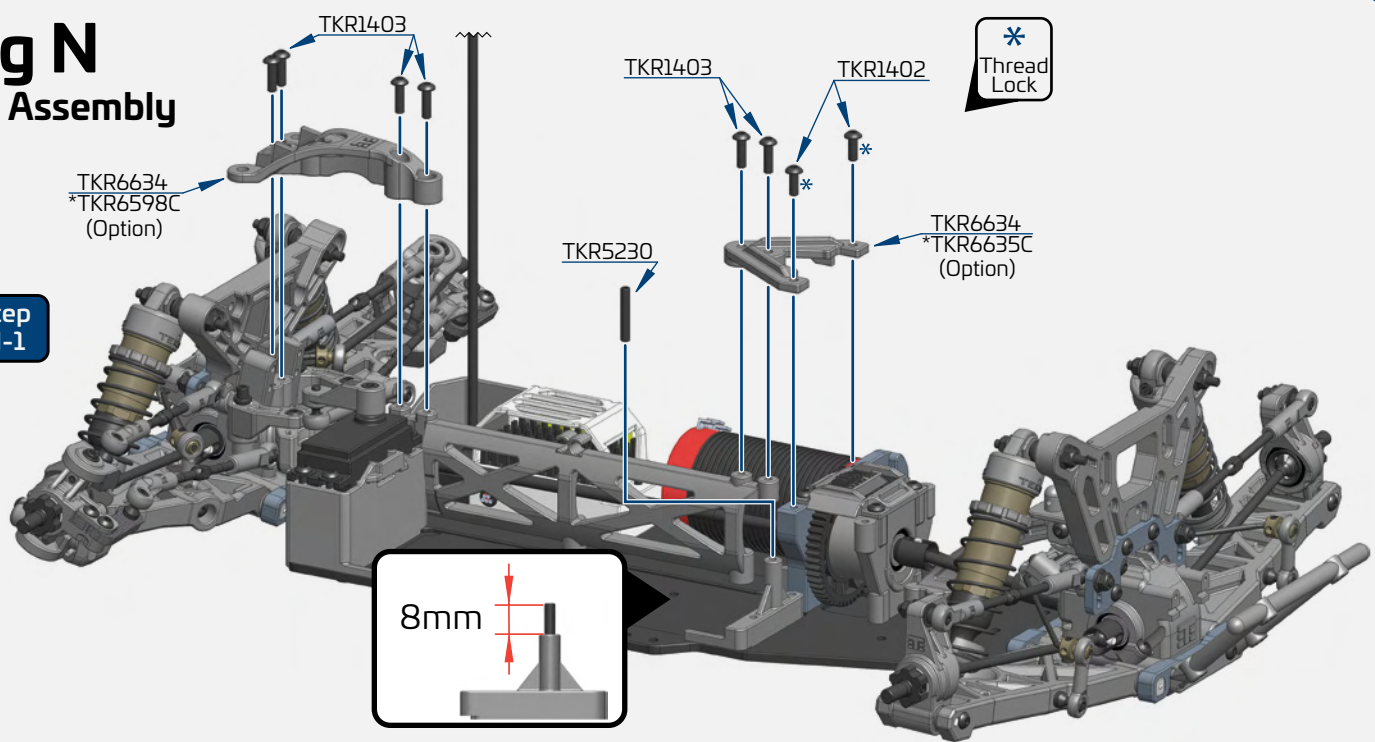

Bag N Final Assembly

* Thread Lock

Step N-1



-  x8
TKR1323
M3x10mm Flat Head Screw
-  x2
TKR1402
M3x8mm Button Head Screw
-  x6
TKR1403
M3x10mm Button Head Screw
-  x1
TKR5230
M3x18 Threaded Rod

Step N-2

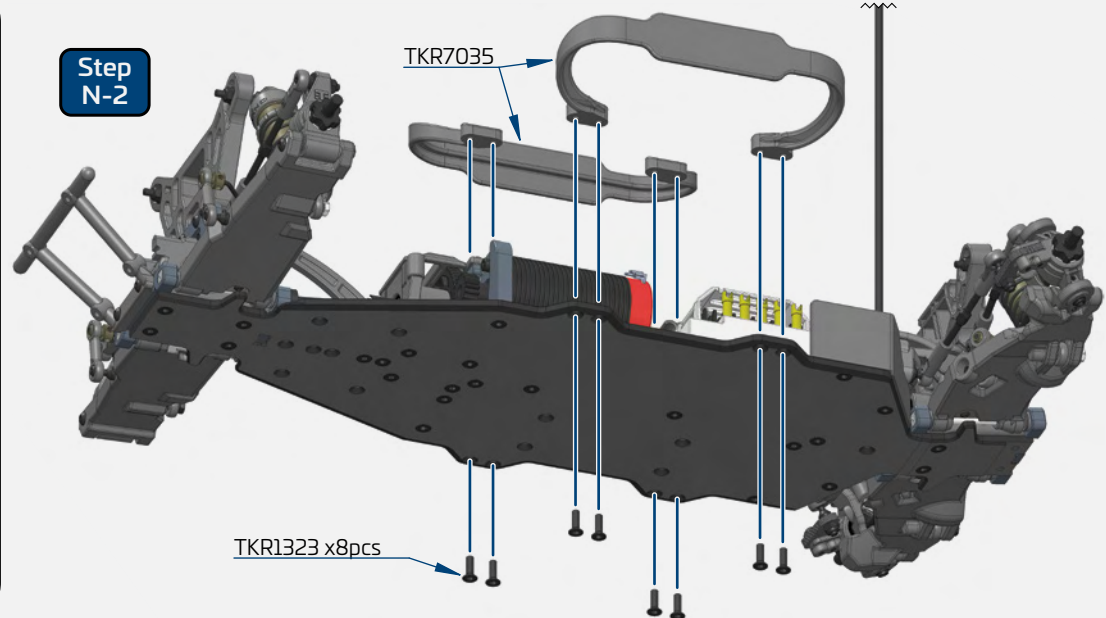

Bag O Body Mounts

Step O-1

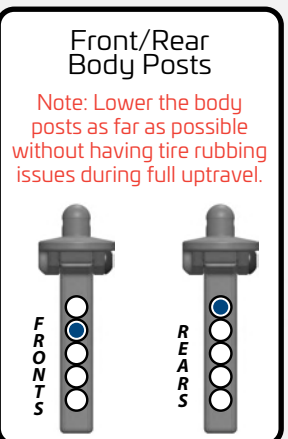
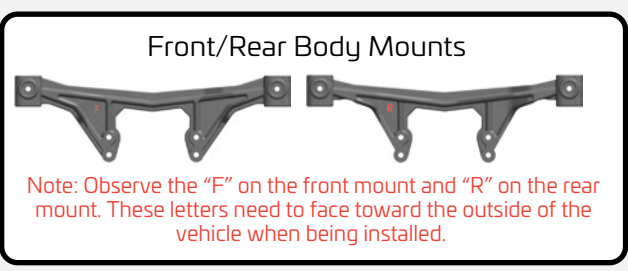

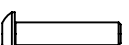
-  x8
TKR1405
M3x14mm Button Head Screw

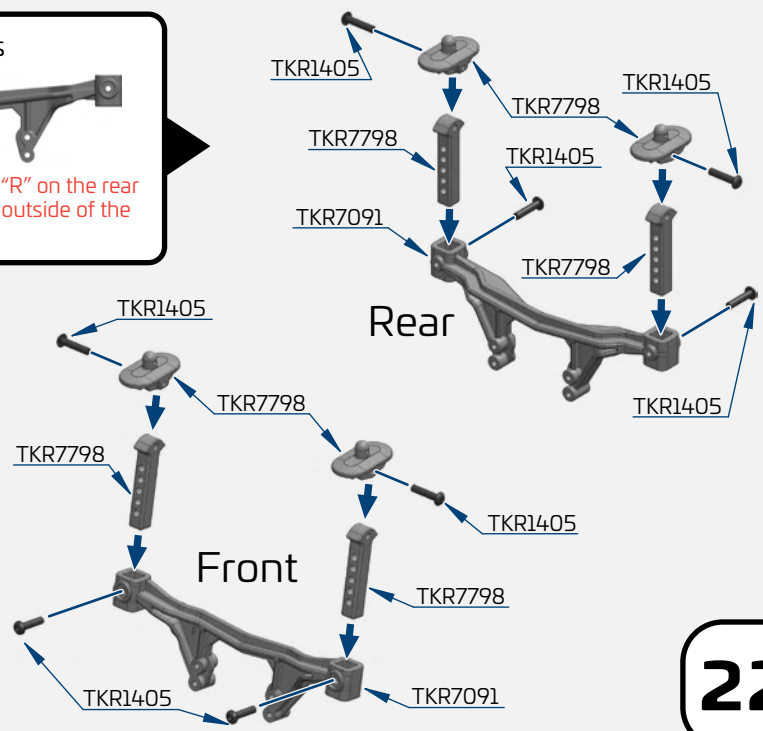

Bag 0

Body Mounts/ Front Bumper

Step
0-2

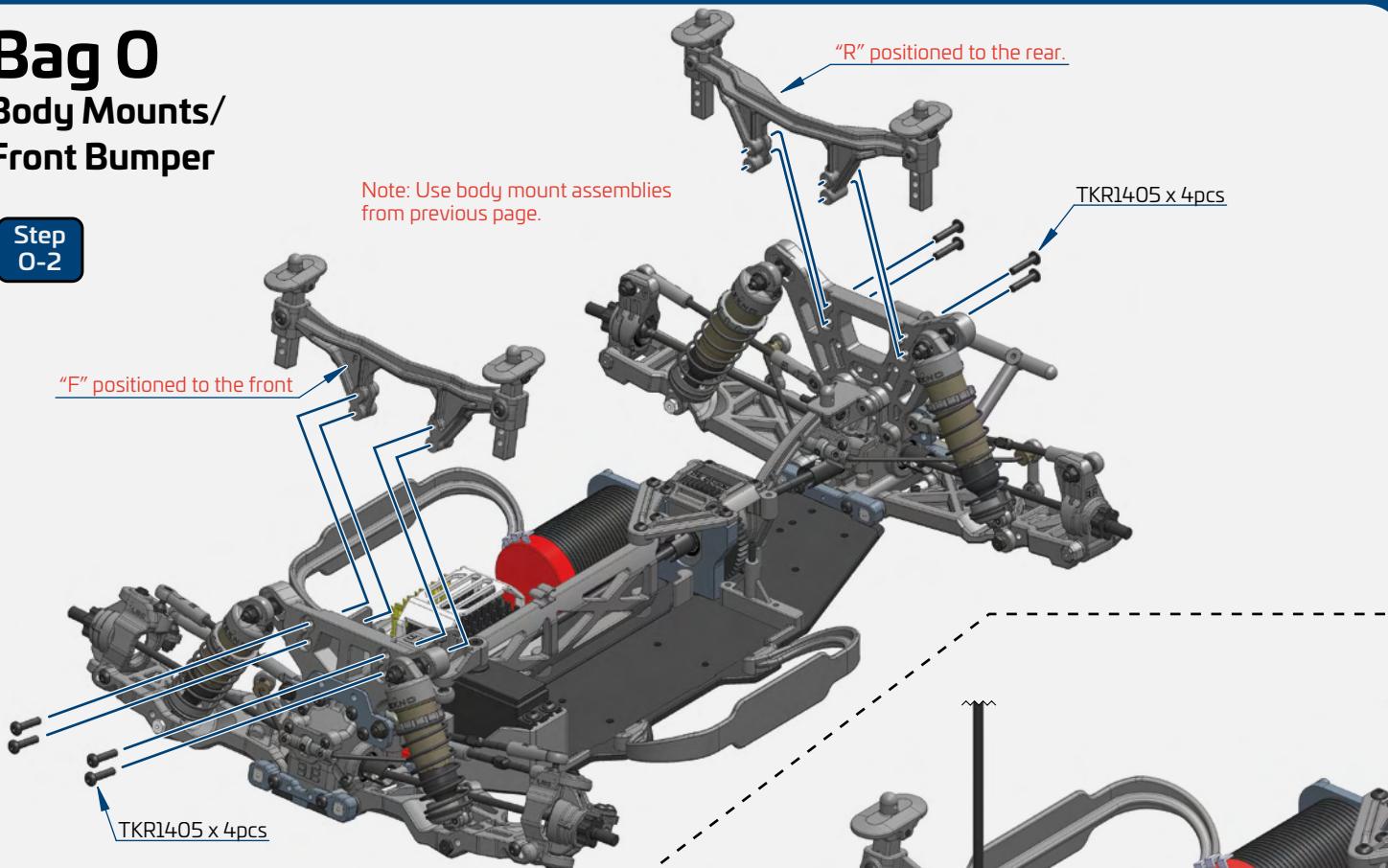

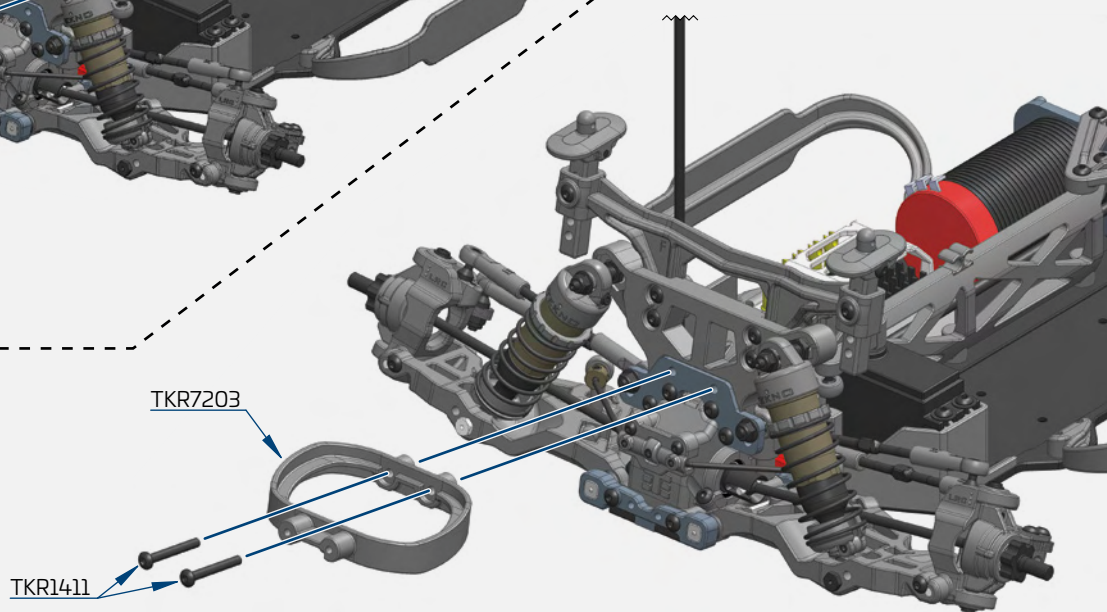

Step
0-3

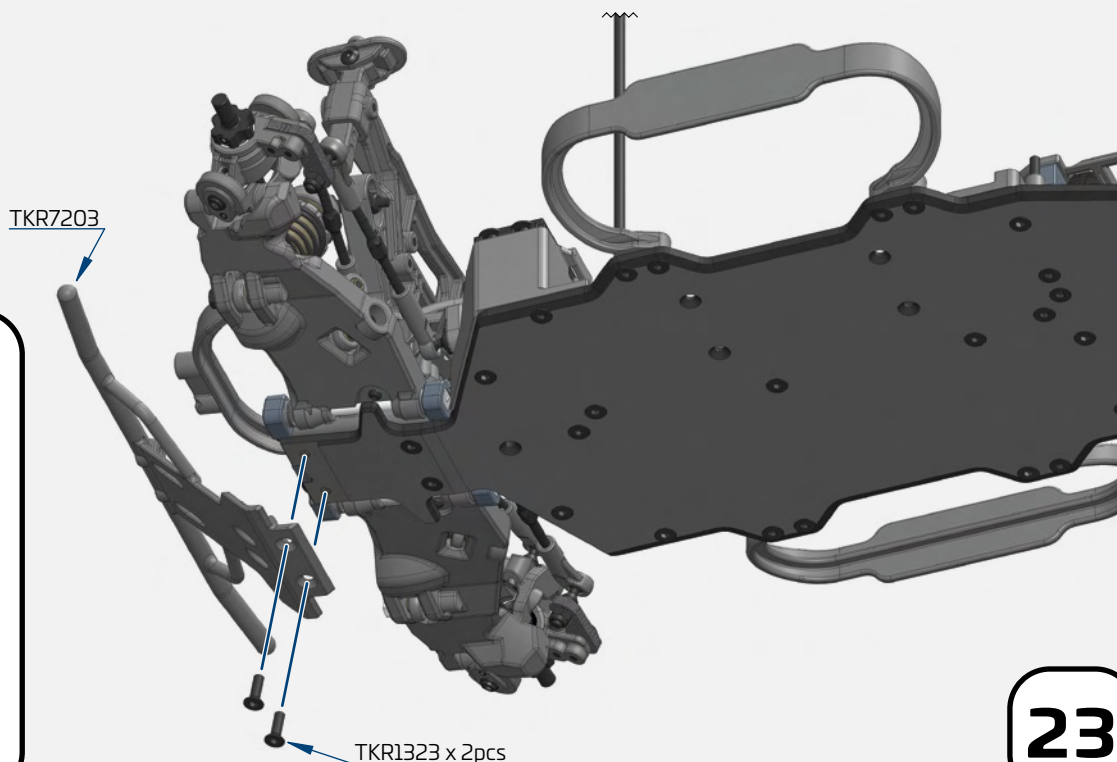

Step
0-4



 x2
TKR1323
M3x10mm Flat Head Screw



 x8
TKR1405
M3x14mm Button Head Screw

 x2
TKR1411
M3x25mm Button Head Screw

Bag 0

Front Bumper

Step
0-5

-  x2
TKR1401
M3x6mm Button Head Screw
-  x2
TKR1405
M3x14mm Button Head Screw

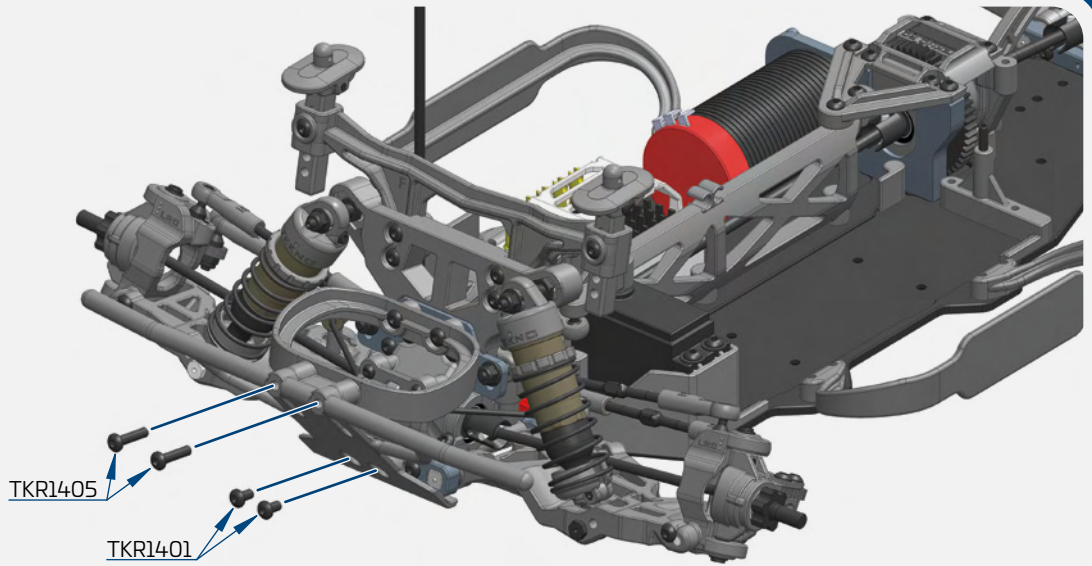

Bag P

Final Assembly

Step
P-1

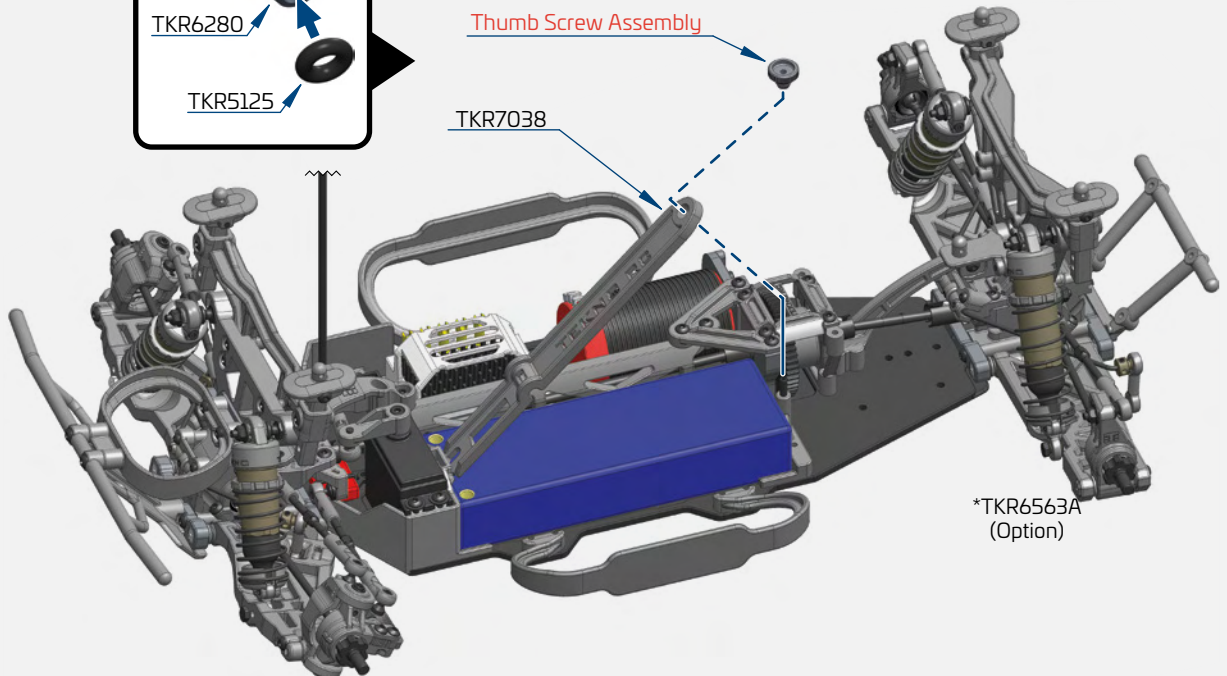
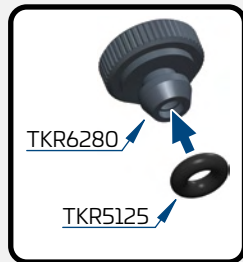

Step
P-2

-  x4
TKR1214
M5 Lock Nut Flange

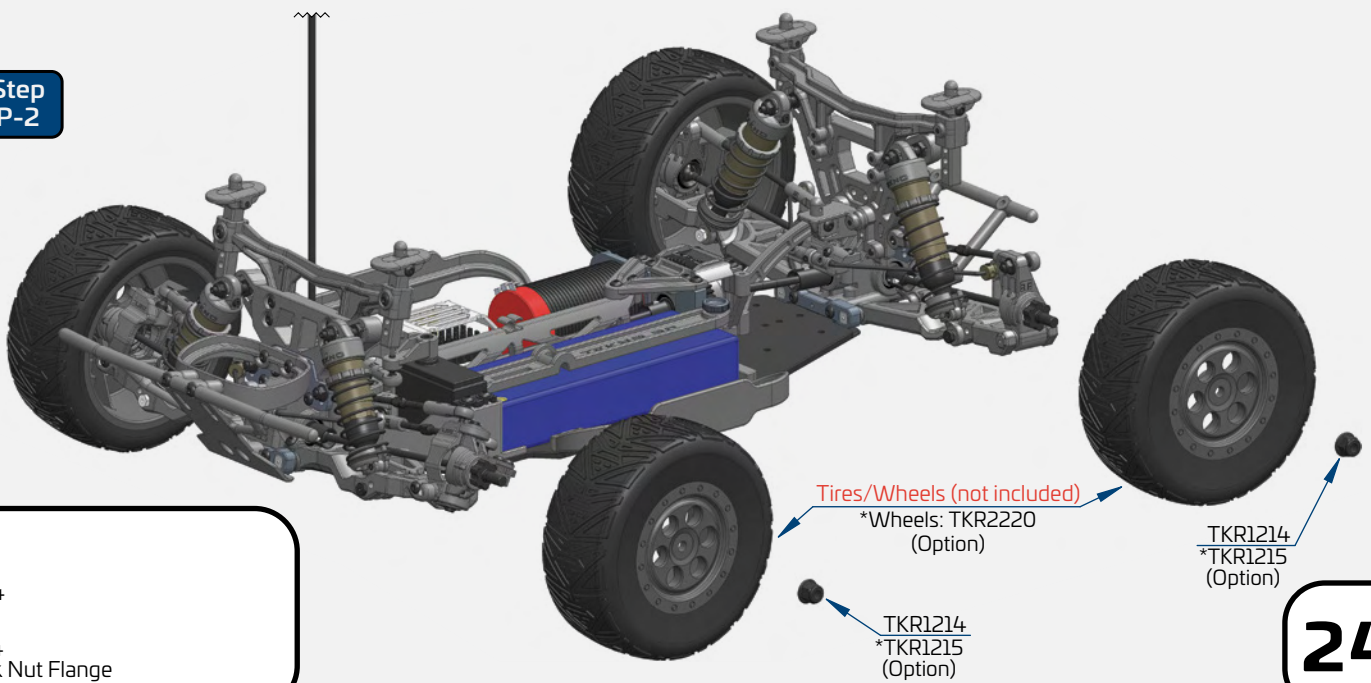

TKR7000 - SCT410SL 1/10th 4x4 Lightweight Short Course Truck Kit

Parts List

TKR5125 - O-Ring (ESC tray, 3pcs)
TKR5126 - Antenna tube (universal, w/ caps, 5pcs)
TKR5230 - Steering linkage (M3x18mm threaded rod, 10pcs)
TKR5571M - Wheel Hexes (12mm, steel, lightened, 4pcs)
TKR6207 - Ball Stud (5.5mm, long neck, 6mm thread, 4pcs)
TKR6208 - Ball Stud (5.5mm, short neck, 8mm thread, 4pcs)
TKR6212 - Ball Stud (5.5mm, short neck, 12mm thread, 4pcs)
TKR6218 - Ball Stud (5.5mm, long neck, 8mm thread, 4pcs)
TKR6250 - Turnbuckle (M3 thread, 55mm length, 4mm adjustment, 2pcs)
TKR6253B - Rod End Set (turnbuckles, sway bar, steering, EB410)
TKR6280 - Battery Strap Thumb Screw (EB410)
TKR6519B - Bulkhead Set (revised, f/r, EB410)
TKR6523HD - Hinge Pins (inner, 3.5mm f/r, requires TKR6544B, 2pcs)
TKR6526C - Bell Cranks, Ackerman Plate, Servo Horns (revised)
TKR6527B - Shock Standoffs (requires TKR6780, EB/ET410, 2pcs)
TKR6540HD - Hinge Pin Brace (CNC, 7075, EB/ET410.2, A Block)
TKR6541HD - Hinge Pin Brace (CNC, 7075, EB/ET410.2, B Block)
TKR6544B - Hinge Pin Inserts, Wheelbase Shims (EB410)
TKR6547 - Sway Bar and Bulkhead Acc. (EB410)
TKR6548 - Pivot Balls (5.5mm, flanged, 4pcs)
TKR6553X - Adjustable Ackermann Spindles (L/R, EB/ET410)
TKR6555 - Stabilizer Balls (5.5mm, sway bars, aluminum, 4pcs)
TKR6565 - Hinge Pins (outer, front, EB410, 2pcs)
TKR6566 - Hinge Pins (outer, rear, EB410, 2pcs)
TKR6576 - Rear Hubs (adjustable Roll Center, L/R, EB410.2)
TKR6586 - Side Guard, Servo Mount, Battery Acc. (EB410)
TKR6590 - Sway Bar Mount (rear, EB410.2)
TKR6596 - Kingpin Shoulder Screws (EB410, 4pcs)
TKR6597HD - Diff Coupler (f/r, HD, hardened steel, EB410/ET410)
TKR6610 - Sway Bar Set (rear, 1.5, 1.6, 1.7, 1.8, 1.9mm, EB410)
TKR6624 - Sway Bar Set (front, 1.5, 1.6, 1.7, 1.8, 1.9mm, EB410/ET410)
TKR6627 - Steering Rack Bushings (aluminum, EB410, 2pcs)
TKR6629B - Steering Posts (revised, steel, EB410.2, 2pcs)
TKR6634 - Center Diff Support, Top Braces (EB410)
TKR6664B - Front Camber Link Plate (revised, aluminum, EB410.2)
TKR6666 - Rear Camber Link Plate (aluminum, EB410.2)
TKR6669B - Spindle Arms (L/R, EB/ET410, requires TKR6553X, Type B)
TKR6856 - CV Rebuild kit (f/r, for 2 axles)
TKR7001 - Chassis (4mm, black ano, SCT410SL)
TKR7013 - Decal Sheet (SCT410SL)
TKR7024 - Suspension Arms (rear, ET410.2)
TKR7030 - Motor Mount (CNC, 7075, SCT410SL)
TKR7035 - Nerf Bars (SCT410SL, L/R)
TKR7038 - Chassis Brace Set and Battery Strap (SCT410SL)
TKR7070 - Stub Axles (SCT410SL, M5 thread, hardened steel, 2pcs)
TKR7080 - Tapered Driveshaft (center, front, 7075, black ano, SCT410SL)
TKR7091 - Body Mount Base Set (SCT410SL)
TKR7099 - Tapered Driveshaft (center, rear, 7075, black ano, SCT410SL)
TKR7163 - Hinge Pin Brace (CNC, 7075, SCT410SL, C Block)
TKR7164 - Hinge Pin Brace (CNC, 7075, SCT410SL, D Block)
TKR7203 - Front/Rear Bumper Set (SCT410SL/ET410)
TKR7225B - Suspension Arms (front, for 3.5mm TKR6523HD pins, ET410)
TKR7250 - Turnbuckle (M3 thread, 78mm length, 4mm adjustment, 2pcs)
TKR7272 - Driveshaft (f/r, hardened steel, ET410, 2pcs)
TKR7281B - Shock Tower Set (f/r, ET410.2)
TKR7623 - Spindle Carriers (L/R, 18°, LRC, EB/ET410)
TKR7798 - Body Post Set (swivel, 4pcs)

Shocks List

TKR6701 - Locking Shock Rod End and Spring Perch Set (13mm shocks)
TKR6704 - Shock Shafts (EB410 front/ET410 rear, steel, 2pcs)
TKR6705E - Shock Piston Set (5x1.1, 5x1.2, flat/flat, 13mm, 4pcs)
TKR6709 - Shock X-rings (8pcs, EB410)
TKR6711 - Shock Body (EB410 front/ET410 rear, aluminum, hard ano, 2pcs)
TKR6712 - Shock/Cartridge Cap & Bushing Set (4pcs each, EB410)
TKR6714 - Emulsion O-ring Set (4x cap seals, 8x emulsion o-rings, for 13mm shocks)
TKR6719 - Shock Adjustment Collar and Guide Set (for 13mm springs, 13mm shocks)
TKR6721 - Shock Boots (medium, for 13mm shocks, 2pcs)
TKR6722 - Shock Boots (long, for 13mm shocks, 2pcs)
TKR6756 - Shock Body (rear, aluminum, hard ano, ET410, 2pcs)
TKR6757 - Shock Shafts (rear, steel, ET410, 2pcs)
TKR6780 - Shock Cap Bushings (requires TKR6527B, EB/ET410, 4pcs)
TKR7041 - Shock Spring Set (front, 1.4x7.875, 5.03lb/in, 50mm, pink)
TKR7244 - Shock Spring Set (rear, 1.3x10.5, 2.61lb/in, 63mm, green)

Bearings List

TKRBB040725 - Ball Bearing (4x7x2.5mm, 4pcs)
TKRBB05114 - Ball Bearing (5x11x4, 4pcs)
TKRBB06124 - Ball Bearing (6x12x4, 4pcs)
TKRBB10154 - Ball Bearing (10x15x4, 4pcs)

Differential List

TKR5144B - Differential O-Rings (2022 spec, fits all TEKNO diffs, 6pcs)
TKR6511 - Differential Case (f/c/r, 3pcs, EB410)
TKR6513X - Differential Cross Pins (composite, 3pcs, EB410)
TKR6514HD - Differential Outdrives (f/r/c, HD, EB410/ET410)
TKR6515 - Differential Seals (3pcs, EB410)
TKR6517 - Differential Shims (5x14mm, hardened, 6pcs, EB410)
TKR6550 - Differential Gear Set (internal gears only, EB410)
TKR7221 - Differential Ring Gear (40t, ET410, use with TKR7222)
TKR7222 - Diff Pinion (10t, ET410, use with TKR7221)
TKR7253 - Spur Gear (53t, 32 pitch, composite, black, EB/ET410)

Hardware List

TKR1201 - M3 Locknuts (black, 10pcs)
TKR1211 - M3 Locknuts (flanged, black, 10pcs)
TKR1214 - M5 Locknuts (flanged, black, 10pcs)
TKR1221 - M3x8mm Washer (black, 10pcs)
TKR1235 - Body Clips (angled, 10pcs)
TKR1240 - Lower Shock Mount Screws (2 CW thread, 2 CCW thread)
TKR1245 - Shock Piston Retainer Screw (4pcs)
TKR1248 - M2x4mm Cap Head Screws (black, 10pcs)
TKR1301 - M2.5x6mm Flat Head Screws (black, 10pcs)
TKR1303 - M2.5x10mm Flat Head Screws (black, 10pcs)
TKR1323 - M3x10mm Flat Head Screws (black, 10pcs)
TKR1400 - M3x4mm Button Head Screws (black, 10pcs)
TKR1401 - M3x6mm Button Head Screws (black, 10pcs)
TKR1402 - M3x8mm Button Head Screws (black, 10pcs)
TKR1403 - M3x10mm Button Head Screws (black, 10pcs)
TKR1405 - M3x14mm Button Head Screws (black, 10pcs)
TKR1409 - M3x20mm Button Head Screws (black, 10pcs)
TKR1411 - M3x25mm Button Head Screws (black, 10pcs)
TKR1463 - M2.5x6mm Button Head Screws (black, 10pcs)
TKR1522 - M3x8mm Cap Head Screws (black, 10pcs)
TKR1523 - M3x10mm Cap Head Screws (black, 10pcs)
TKR1601 - M3x4mm Set Screws (black, 10pcs)
TKR1602 - M4x4mm Set Screws (black, 10pcs)
TKR1604 - M3x8mm Set Screws (black, 10pcs)
TKR1609 - M3x3mm Set Screws (black, 10pcs)
TKR1611 - M4x8mm Set Screws (black, 10pcs)

Option Parts

TKR1103 - Turnbuckle Wrench (4mm, 5mm, hardened steel)
TKR1115 - Pivot Ball and Shock Multi-tool (aluminum)
TKR1119 - 5.5mm / 7.0mm Wrench (hardened steel)
TKR1654X - 12mm Aluminum Hex Adapters (+1mm, aluminum, 4pcs)
TKR2220 - TR606 SCT Wheel (black, SCT410 offset, 4pcs)
TKR5571A - Wheel Hexes (SCT410, 12mm, aluminum, 4pcs)
TKR6514 - Differential Outdrives (f/r/c, EB410)
TKR6560A - Aluminum Ackerman Plate (CNC 7075 black ano, EB410/ET410)
TKR6563A - Aluminum Servo Horn (2ST, standard, low profile, M3 clamp, EB410)
TKR6597 - Diff Coupler (f/r, hardened steel, EB410)
TKR6598C - Steering Top Plate (carbon fiber, EB410)
TKR6611 - Sway Bar Set (rear, bars only, 1.0, 1.1, 1.2, 1.3, 1.4mm, EB410/ET410)
TKR6625 - Sway Bar Kit (front, 1.0, 1.1, 1.2, 1.3, 1.4mm, EB410)
TKR6635C - Center Diff Top Plate and Fan Mount (carbon fiber, EB410)
TKR6669A - Spindle Arms (L/R, EB/ET410, requires TKR6553X, Type A)
TKR6669C - Spindle Arms (L/R, EB/ET410, requires TKR6553X, Type C)
TKR6669D - Spindle Arms (L/R, EB/ET410, requires TKR6553X, Type D)
TKR6704T - Shock Shafts (EB410 rear/ET410 front, steel, TiNi coated, 2pcs)
TKR6708 - Shock Cartridge Guide Set (CNC, Delrin, 8pcs, EB410/ET410)
TKR6712A - Shock Caps (7075, emulsion, black ano, 2pcs)
TKR6719A - Shock Adjustment Collars (aluminum, EB410, 2pcs)
TKR6731 - Shock Pistons (CNC, 2x1.7, 2pcs)
TKR6732 - Shock Pistons (CNC, 2x1.8, 2pcs)
TKR6735 - Shock Piston Blanks (CNC, flat/flat, 13mm, 4pcs)
TKR6736 - Shock Pistons (CNC, 8x1.1, flat/flat, 13mm, 2pcs)
TKR6737 - Shock Pistons (CNC, 8x1.2, flat/flat, 13mm, 2pcs)
TKR6738 - Shock Pistons (CNC, 8x1.3, flat/flat, 13mm, 2pcs)
TKR6739 - Shock Pistons (CNC, 5x1.1, flat/flat, 13mm, 2pcs)
TKR6740 - Shock Pistons (CNC, 5x1.2, flat/flat, 13mm, 2pcs)
TKR6757T - Shock Shafts (rear, steel, TiNi coated, ET410, 2pcs)
TKR7039 - Shock Spring Set (front, 1.4x8.375, 4.63lb/in, 50mm, grey)
TKR7040 - Shock Spring Set (front, 1.4x8.125, 4.82lb/in, 50mm, black)
TKR7042 - Shock Spring Set (front, 1.4x7.625, 5.25lb/in, 50mm, green)
TKR7043 - Shock Spring Set (front, 1.4x7.375, 5.48lb/in, 50mm, yellow)
TKR7044 - Shock Spring Set (front, 1.4x7.125, 5.75lb/in, 50mm, orange)
TKR7045 - Shock Spring Set (front, 1.4x7.0, 5.90lb/in, 50mm, red)
TKR7224B - Suspension Arms (rear, for 3.5mm TKR6523HD pins, ET410)
TKR7242 - Shock Spring Set (rear, 1.3x12.125, 2.2lb/in, 63mm, black)
TKR7243 - Shock Spring Set (rear, 1.3x11.25, 2.4lb/in, 63mm, pink)
TKR7245 - Shock Spring Set (rear, 1.3x9.875, 2.82lb/in, 63mm, yellow)
TKR7246 - Shock Spring Set (rear, 1.3x9.375, 3.01lb/in, 63mm, orange)
TKR7247 - Shock Spring Set (rear, 1.3x8.875, 3.22lb/in, 63mm, red)
TKR7281C - Shock Tower (front, carbon fiber, ET410)
TKR7282C - Shock Tower (rear, carbon fiber, ET410)

Set Up Information

The purpose of making adjustments is to make the car go faster around the track, or to make it more controllable, or both if possible. A car that's easier to drive should produce lower, more consistent lap times. It will also inspire more confidence in the driver, which is always good when nerves start getting the best of you.

Before you start thinking about changing your car's setup, consider these two things: First, is the car in perfect working order? Be sure that all of the suspension components operate freely without excessive play, and that the car isn't tweaked. Binding and worn out parts will result in poor performance and inconsistent handling. Second, always consider tires before making other adjustments. Time spent trying to get the vehicle to work with the wrong tires mounted will be wasted time. Without the right tires, even a great setup won't be a winning setup.

Ride Height

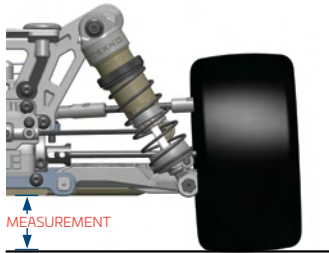

Ride height is the distance from the bottom of the chassis to the running surface. Ride height should only be checked and adjusted with your vehicle ready to run (i.e. with battery installed/body on). Ride height is the first adjustment to be made and should be set with a ride height measurement tool. Measurements should be taken from the flat parts of the chassis, front and rear. Be sure to measure the front ride height at a point before the kick up in the chassis starts. To measure ride height, first make sure the suspension is completely free, then simultaneously compress the front and rear all the way down and let the vehicle settle. Take your measurement from that position. Use the shock spring adjustment collars to raise or lower the ride height to your desired setting. 18 - 22mm front and rear is a good starting point.

Camber

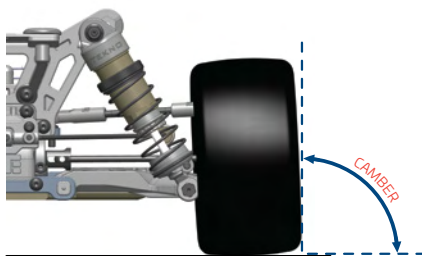

Static camber affects the car's side to side traction. More negative camber front and rear quickens rotation in corners. Less negative camber will make the vehicle easier to drive but you may give up some responsiveness (i.e. steering). To set your static camber have your vehicle at ride height (see above) and adjust the camber links until desired angle is achieved. Please note that a large adjustment of front camber will affect front toe and you may have to readjust the toe and then re-check front camber again. A good starting measurement for camber is 1-2 degrees in the front and 1.5-2.5 degrees in the rear.

Front Toe

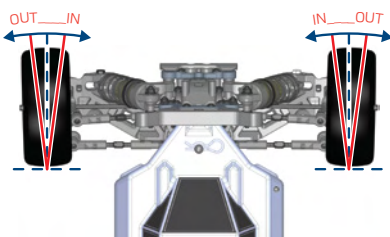

Front toe is used to describe the angle in which the front wheels point when looking down at them from the top of a vehicle. You will always use some amount of toe out. Toe-out will affect how your vehicle enters and exits corners. More toe out will result in more off-power steering and less on-power steering and less toe out will have the opposite results. To set your front toe, have your vehicle at ride height (see above) and adjust the steering links until desired angle is achieved. Please note that a large adjustment of front toe will affect front camber and you may have to readjust the camber and then re-check front toe again. A good starting point is approximately 1-2 degrees of toe out.

Ackermann Effect

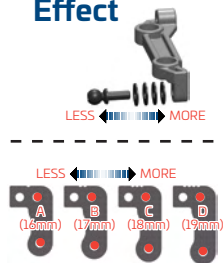

Think of Ackermann as active toe when the steering moves from left to right. More Ackermann effect makes more toe out at full turn and produces more steering off-power. Less Ackermann effect makes less toe out at full turn and produces more steering on-power. A good starting point is 2 washers behind the ball stud (TKR6207), and the B spindle arm.

Bumpsteer



Think of bump steer as active toe when the suspension compresses or rebounds. To adjust bump steer you have to change the angle of the steering link. This is accomplished by adding or removing washers under the ball stud on the steering spindles, or by adding or removing riser plates under the spindle arms. Anytime you change camber link locations, front arm pills, front arm spacers, or Ackermann you will need to check and possibly adjust your bumpsteer. It's best to start with zero bumpsteer or slight bump out. Bump in should never be used.

Droop

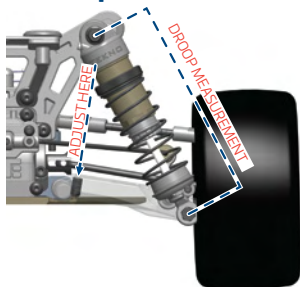

Droop is the measured amount of down travel in the suspension. It is measured from the shock mounting points while the vehicle is up on a stand allowing the arms to hang freely and is adjusted by turning the droop screw located in the suspension arms front/rear. This screw limits the suspension travel by providing a stopping point against the chassis. Left and right sides should always be equal, however the front and rear of the vehicle can have different values. Droop affects all aspects of chassis performance, including: braking, acceleration, jumping, traction and bump handling. A good starting droop measurement is 85mm front and 103mm rear.

Set Up Information

(continued)

Differentials



Front: Changing front diff oil affects overall steering response. Thinner can increase off-power steering but the vehicle may be twitchy and harder to drive. Thicker can increase on power steering and stability. We recommend 10k to 50k in the front diff.

Center: Changing center diff oil affects the front-to-rear drive balance. Thicker will reduce off-power steering and on-power rear traction but increases on-power steering and acceleration if traction is available. Thinner will increase off-power steering and on-power rear traction but reduce on-power steering and acceleration. We recommend 20k to 50k in the center diff.

Rear: Thinner rear diff oil increases off-power steering and reduces traction into a corner. It also reduces on-power steering and increases traction out of a corner. Going too thin will make your vehicle inconsistent, however. Thicker rear oil will have opposite effects, and once again, going too thick will make the vehicle inconsistent. We recommend 15k to 30k in the rear diff.

Wheelbase Adjustments

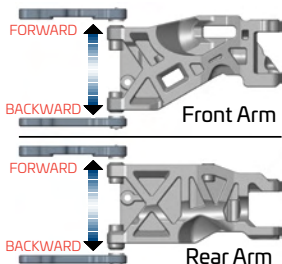

Changes to wheelbase can affect the overall handling of your vehicle, since it adjusts the distribution of weight on the wheels as well as the angle of the driveshafts. Shortening the wheelbase at the rear will give you more steering into a turn and off power, less steering out of a turn and on power. Lengthening the wheelbase at the rear will yield the opposite results.

Shortening the wheelbase in the front will land jumps a little better and lengthening it will be better through small bumps. In general a longer wheelbase is better on open and/or bumpy tracks and a shorter wheelbase is better on tighter technical tracks.

Springs

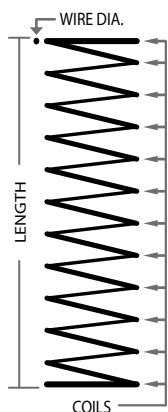

PART#/COLOR	F / R	WIRE DIA.	COILS	LENGTH	RATE
TKR7039	Front	1.4	8.38	50mm	4.63
TKR7040	Front	1.4	8.13	50mm	4.82
TKR7041	Front	1.4	7.88	50mm	5.03
TKR7042	Front	1.4	7.63	50mm	5.25
TKR7043	Front	1.4	7.38	50mm	5.48
TKR7044	Front	1.4	7.13	50mm	5.75
TKR7045	Front	1.4	7.00	50mm	5.90
TKR7242	Rear	1.3	12.13	63mm	2.21
TKR7243	Rear	1.3	11.25	63mm	2.40
TKR7244	Rear	1.3	10.50	63mm	2.61
TKR7245	Rear	1.3	9.87	63mm	2.82
TKR7246	Rear	1.3	9.37	63mm	3.01
TKR7247	Rear	1.3	8.87	63mm	3.22

Softer springs will increase traction through the turns by allowing more roll, slow down the responsiveness of the vehicle, and can be better in the bumps. Stiffer springs will increase corner speed if traction is available and will also tend to jump and land better. Once you find a set of springs you like you will typically only change them for

tracks with dramatically different conditions.

Pistons

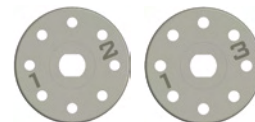

Pistons with smaller or fewer holes work well for smoother tracks with large jumps, and pistons with larger holes or more holes, work well for rougher tracks with less jumps. Smaller hole pistons will typically use thinner oil than larger hole pistons. Shock oil is also affected by the ambient temperature so a change in viscosity might be necessary with a change of 5°C or ~10°F.

Sway Bars

Part#	F/R	Size
TKR6623	Front	1.0mm
TKR6623	Front	1.1mm
TKR6623	Front	1.2mm
TKR6623	Front	1.3mm
TKR6623	Front	1.4mm
TKR6610	Rear	1.5mm
TKR6610	Rear	1.6mm
TKR6610	Rear	1.7mm
TKR6610	Rear	1.8mm
TKR6610	Rear	1.9mm

Sway bars are used to adjust a vehicle's lateral grip by resisting chassis roll. A thicker bar decreases roll more than a thinner bar will. More roll means more grip and less roll means less grip. The front sway bar affects mainly off-power steering at corner entry. The rear sway bar affects mainly on-power steering and stability in mid-corner and at corner exit.

Bearing Chart

	TKRBB040725 – Ball Bearings (4x7x2.5mm, sold in pack of 4pcs) Bearings for the bellcrank/ackerman plate. 8pcs required in kit.
	TKRBB05114 – Ball Bearings (5x11x4, 4pcs) Diff pinion support bearings for the front/rear transmission housings. 4pcs required in kit.
	TKRBB06124 – Ball Bearings (6x12x4mm, 4pcs) Bearings for outside of steering blocks and outer rear hub carriers. 4pcs required in kit.
	TKRBB10154 – Ball Bearings (10x15x4mm, sold in pack of 4pcs) Bearings for all three diffs. Also inner front steering blocks/rear hub carriers. 10pcs required in kit.

* For bearing maintenance, please refer to page 29.

Gearing Recommendations

Motor	Small Track (pinion)	Large Track (pinion)
540/550		
4-Pole	(50-80 ft Straight)	(80-150 ft Straight)
3800kv	19 tooth	21 tooth
4300kv	17 tooth	19 tooth
4600kv	16 tooth	18 tooth

This chart shows the recommended starting ratios for the common motor winds. Please consult the motor/esc manufacturers recommended settings to ensure you start with the best final drive ratio (FDR) for your equipment. When setting your mesh you want to be able to *slightly* rock the spur gear back and forth without moving the pinion gear. Tekno RC is not responsible for damage done to your electronic equipment or gears due to improper gearing or mesh.

Radio Information

Please read thoroughly

The Tekno RC SCT410SL is highly tunable, but can be very aggressive depending on track conditions and tires used. To help with this, we recommend that you are well informed about setting up your Steering End Points (EPA), Dual Rate (D/R), Exponential Curves, and Servo Speed.

Start by setting your EPA such that the vehicle can reach 'full lock' while on the ground. Be careful not to go too far with this setting as it may damage your servo. Drive the vehicle around the track. If you are turning into pipes or losing traction out of a corner, you probably have too much overall steering throw. The simplest way to reduce this is with Dual Rate. Reducing Dual Rate will turn down both the left and right side EPA proportionately without having to adjust the EPA settings independently. D/R is usually pre-assigned to one of the trim buttons on most mid-to-high level radios.

The next setting is 'Expo' or 'Curve'. Expo does not change your EPA or D/R, it simply turns the wheels less around center and ramps up to the end points as you reach full lock on the steering wheel. We would suggest starting at -15%. If you're vehicle still feels "twitchy" around center, dial in more negative expo to continue smoothing everything out. If it starts to feel too numb around center, dial some back out.

Another valuable and often overlooked radio adjustment is "Servo Speed". Servo Speed allows you to slow the steering servo down from the transmitter resulting in reduced twitchiness. We like to set this at around -40 to start. If you find that it's too lazy, increase the servo speed slightly and run a few more laps. Repeat as necessary until the steering response feels natural without delay.

After setting the servo speed you might find that you need to go back and adjust the expo setting. This is normal, it might take a few adjustments of each to achieve the proper steering "feel" to suit your driving style and track conditions.

With these four settings, you should be able to make your vehicle consistent and easy to drive lap after lap assuming the rest of the setup is close for your particular track. Of course there are many other factors and setup options to tune for more or less steering, but sometimes all your vehicle needs is a small radio adjustment to keep you headed in the right direction.

Notes:

Maintenance:

Performing regular maintenance will greatly improve your on track consistency and also extend the life of your vehicle. Going through critical areas of the vehicle regularly will also allow you to find possible issues before they become a problem that may cost you a race. Follow the guidelines below for maximum performance.

Bearing Maintenance:

Bearings should always be smooth and free in order to perform their function. We recommend inspecting and cleaning each bearing on a regular basis. It will be necessary to break down parts of the vehicle in order to inspect them properly. The procedures below should be done every couple of weeks or prior to an important race.

1. Inspect the outer seals for any visible damage and check the rolling resistance of each bearing.
2. If any bearing does not spin freely, then take the following steps to clean them.
3. Spray the bearing with motor spray and spin it again to remove any debris trapped inside. Repeat if necessary. If the bearing does not start to spin freely after cleaning, then they may need to be replaced.
4. Allow the clean bearing to dry or blow into the bearing with compressed air to speed up the drying process.
5. Oil each bearing with a proper bearing lubricant. One or two drops is enough.

Shock Maintenance:

When comparing the left and right shocks of the front end, they should feel identical. Same goes for the rears. The procedures below should be done every race day to make sure they are leak free and operating correctly.

1. After removing the shocks from the vehicle, remove the springs and inspect each shock for visible leaks (build up of debris at the bottom of the shock shaft or visible oil).
2. If the shock binds when pushing the shaft through its stroke, then the shaft may be bent and will need to be replaced.
3. If the shocks from left to right do not feel consistent when compared to each other, or have built up too much air inside (feel empty when pushing the shaft through its stroke), then you will need to rebuild them following the steps outlined on page 19 of this manual.

Hinge Point & Drive Line Maintenance:

Checking the hinge points while the shocks are removed from the vehicle is the best time to inspect these parts. The other items to inspect are the camber links, steering links and drive shafts. Follow the steps below every couple of weeks in order to keep the vehicle performing at maximum.

1. With the shocks off the vehicle, check the movement of the arms, hubs and spindle carriers. They should move freely. If there is a bind, then the inner or outer hinge pin may be bent and would need to be replaced. The arms should not have any play when twisted or moved in any direction against the hinge points. If there is excessive slop present, then the arms or hubs may be worn and will need to be replaced.
2. Remove the camber links, steering links and servo link from the vehicle. Check the movement of the spindles to see if they turn freely. If they don't, then check the kingpin shoulder screws to see if they are tightened down too far. Also, check for slop. If there is excessive slop present, then the spindle carriers may need to be replaced.
3. Check the steering rack to make sure it moves freely. If it binds, then the screws holding the Ackermann or the steering posts could be too tight. If they still bind, then check the bearings and follow the steps above to clean them.
4. After re-installing the camber links, steering links and servo link, check the movement of the rod ends on the ball studs. If they have excessive slop or are binding, then they may need to be replaced.
5. Check the drive shafts by rotating them. Look for any wobbles. If they are bent, replace them immediately.
6. With the drive shafts removed, check for slop in the CV area. If it is present, then reposition the CV pin to another fresh hole, re-lubricate and install back into the vehicle.

Differential Maintenance:

Properly maintained differentials are essential for a smooth operating vehicle. Check all three diffs regularly to make sure they are filled and operating as designed.

1. Remove each diff and verify the differential action is happening and is smooth. If there is any notchy feel to them, follow the steps below to rebuild them.
2. Open the diff and pour out the oil. Remove the gears and pins to release the outdrives. Then remove the seals. Inspect everything to make sure there are no damaged parts. If the seals are old or show any signs of degradation, replace them immediately. Re-lubricate the seals and outdrives, then rebuild the diff following the steps on page 3 and 4.

Name: Box Stock

Date: _____

Event: _____

Track: INDOOR OUTDOOR Size: SMALL MEDIUM LARGE Traction: LOW MEDIUM HIGH

Surface: SMOOTH BUMPY RUTTED Type: LOOSE / LOAMY HARD PACKED BLUE GROOVE CLAY ASTRO

Steering Stop/Arm Settings/Ackerman: _____

Condition: DUSTY DRY WET MUDDY



Front End:

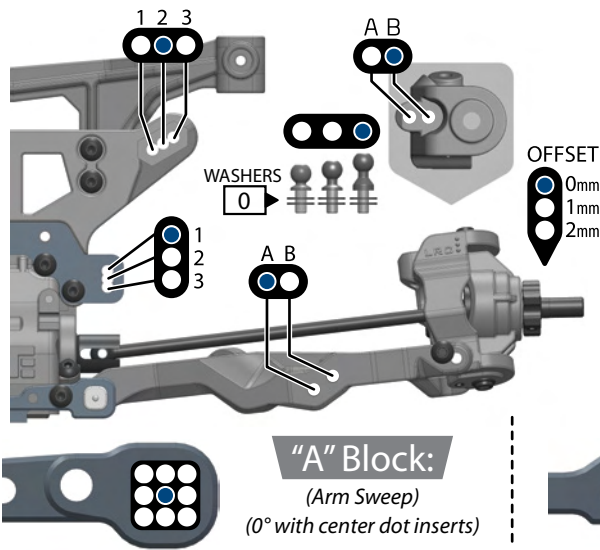

Suspension:

RIDE HEIGHT: 20 CAMBER: -2°
 CASTER: 18° SWEEP: 0°
 KICK UP: 10° TOE: 2° out
 SWAY BAR: 1.5mm DROOP: 85mm

Shocks:

OIL: 400 CST BRAND: Kit
 PISTON: 5x1.1 SPRING: TKR7042
 REBOUND: 0% BUILD: emul

Differential Oil:

FRONT	CENTER	REAR
30k	/ 30k	/ 20k

Drivetrain:

PINION / SPUR: / 53 (teeth)

Equipment:

MOTOR:

ESC:

BATTERY:

RADIO:

SERVO: 240oz min

Chassis Braces:

REAR-SHORT: REAR-LONG:

Tires / Wheels:

BRAND / TREAD:

COMPOUND:

INSERT:

WHEEL:

NOTES:

Body

BODY MAKE:

Notes:

Rear End:

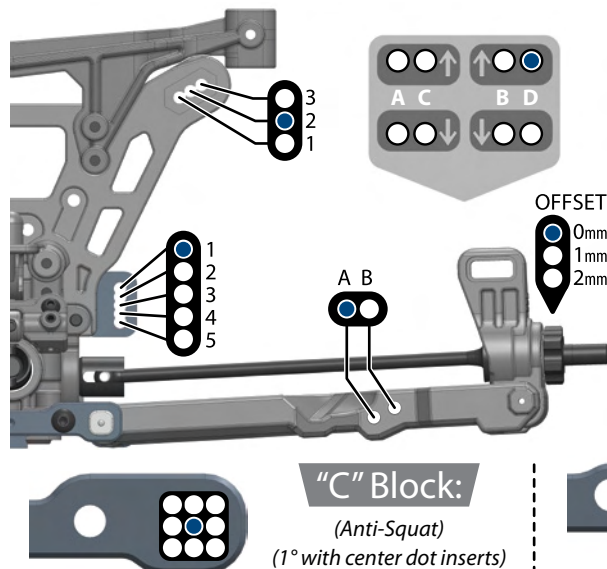

Suspension:

RIDE HEIGHT: 20 CAMBER: -2°
 ANTI-SQUAT: 1° TOE: 3.5°
 SWAY BAR: 1.5mm DROOP: 103mm

Shocks:

OIL: 400CST BRAND: Kit
 PISTON: 5x1.2 SPRING: TKR7247
 REBOUND: 0% BUILD: emul

Rear Hub:

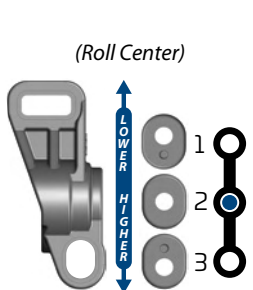

Wheelbase:

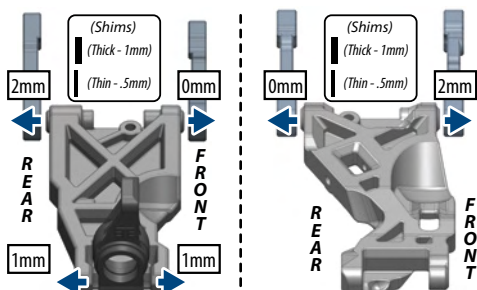

Body Mounts:

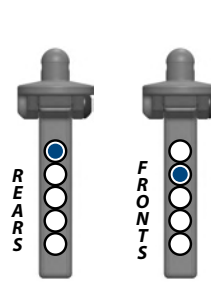

Name: _____ Date: _____ Event: _____

Track: INDOOR OUTDOOR Size: SMALL MEDIUM LARGE Traction: LOW MEDIUM HIGH

Surface: SMOOTH BUMPY RUTTED Type: LOOSE / LOAMY HARD PACKED BLUE GROOVE CLAY ASTRO

Steering Stop/Arm Settings/Ackerman: _____ Condition: DUSTY DRY WET MUDDY

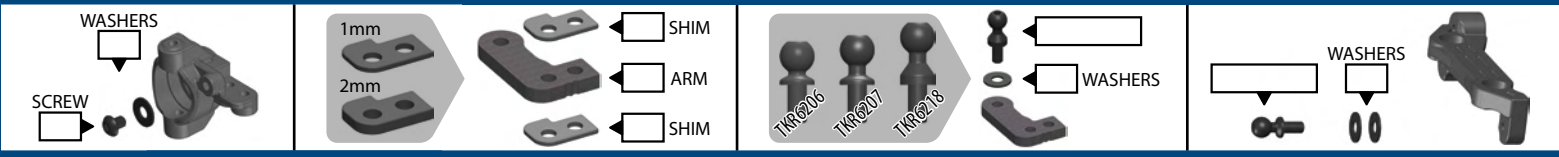

Front End:

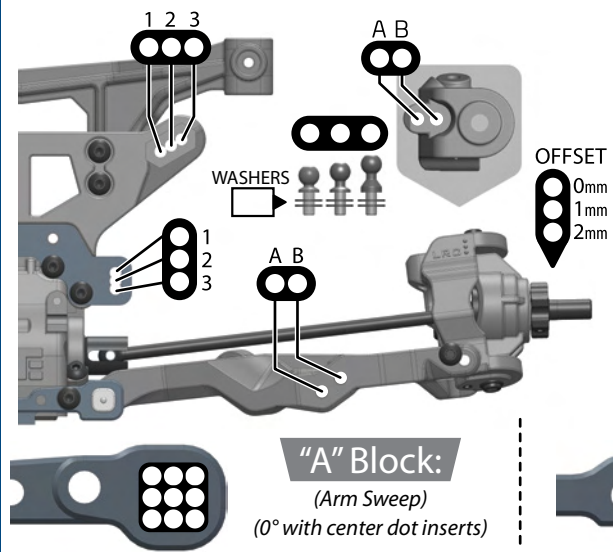

Suspension:

RIDE HEIGHT:	CAMBER:
CASTER:	SWEEP:
KICK UP:	TOE:
SWAY BAR:	DROOP:

Shocks:

OIL:	BRAND:
PISTON:	SPRING:
REBOUND:	BUILD:

Differential Oil:

FRONT	CENTER	REAR
/	/	/

Drivetrain:

PINION / SPUR: _____ / _____ (teeth)

Equipment:

MOTOR:

ESC:

BATTERY:

RADIO:

SERVO:

Chassis Braces:

REAR-SHORT: REAR-LONG:

Tires / Wheels:

BRAND / TREAD:

COMPOUND:

INSERT:

WHEEL:

NOTES:

Body

BODY MAKE:

Notes:

Rear End:

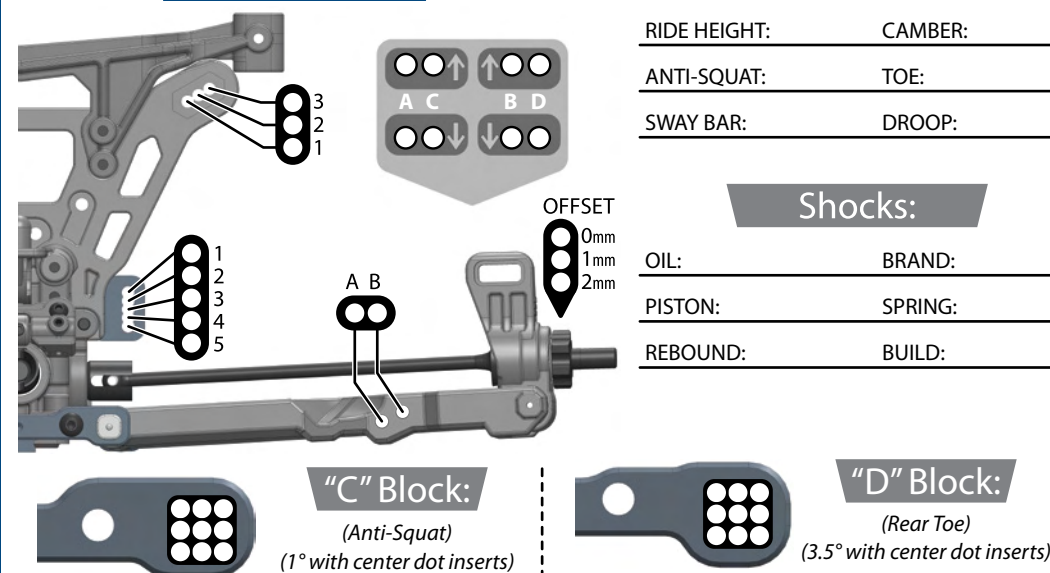

Suspension:

RIDE HEIGHT:	CAMBER:
ANTI-SQUAT:	TOE:
SWAY BAR:	DROOP:

Shocks:

OIL:	BRAND:
PISTON:	SPRING:
REBOUND:	BUILD:

Rear Hub:

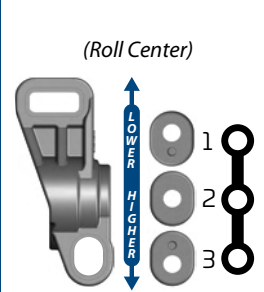

Wheelbase:

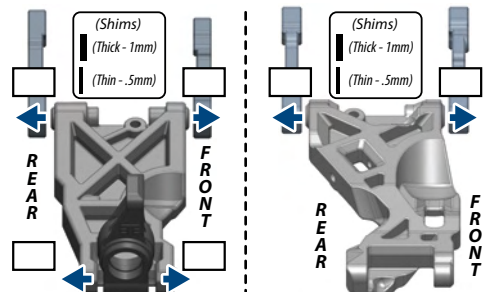

Body Mounts:

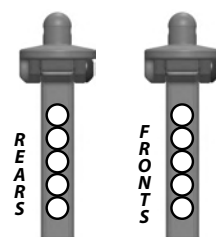



Tekno RC
10755 Scripps Poway Pkwy #598
San Diego CA 92131
USA

www.teknorc.com

SCT410SE