

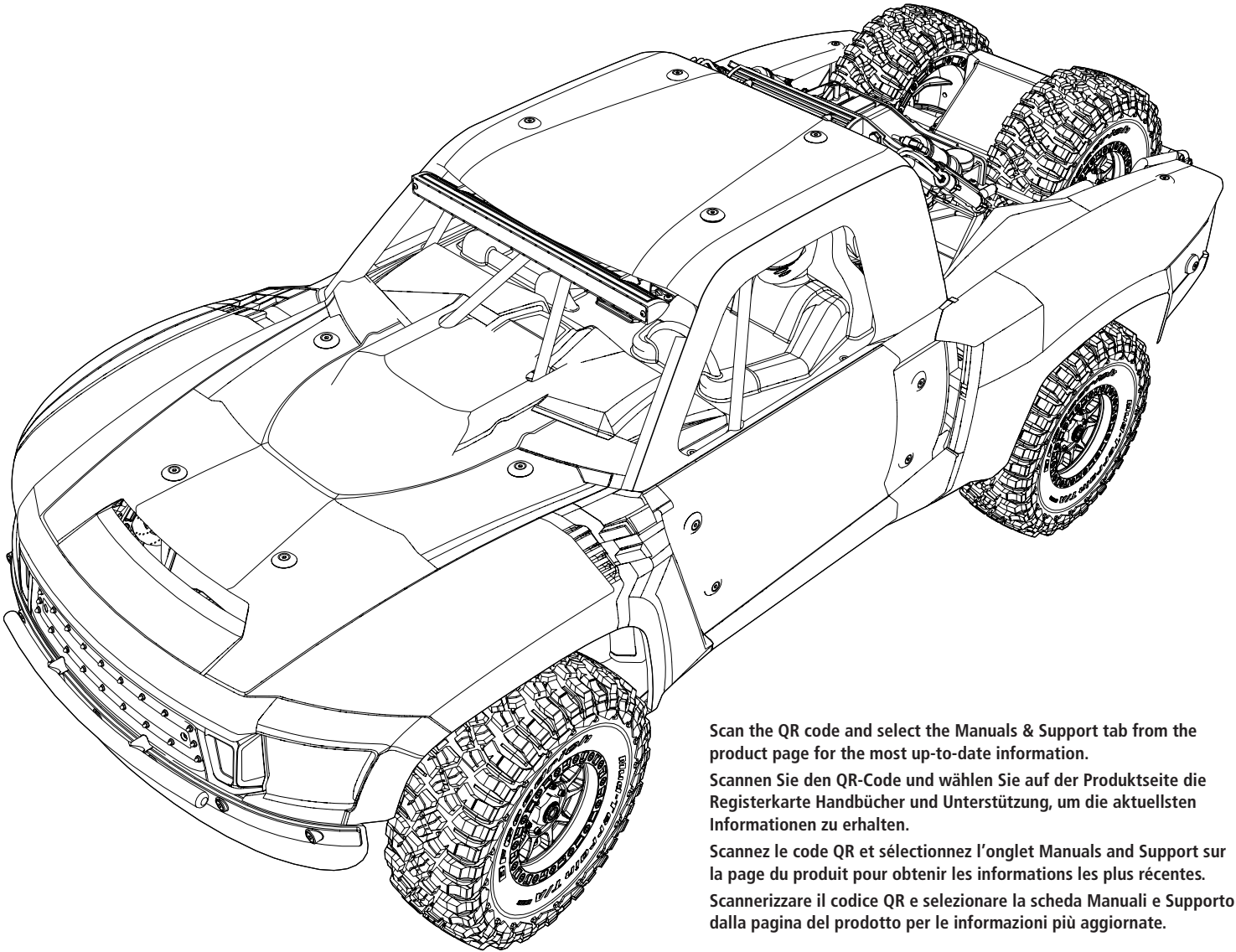

RTR
READY-TO-RUN



Super BAJAREY 2.0



Scan the QR code and select the Manuals & Support tab from the product page for the most up-to-date information.

Scannen Sie den QR-Code und wählen Sie auf der Produktseite die Registerkarte Handbücher und Unterstützung, um die aktuellsten Informationen zu erhalten.

Scannez le code QR et sélectionnez l'onglet Manuals and Support sur la page du produit pour obtenir les informations les plus récentes.

Scannerizzare il codice QR e selezionare la scheda Manuali e Supporto dalla pagina del prodotto per le informazioni più aggiornate.

**INSTRUCTION MANUAL
BEDIENUNGSANLEITUNG
MANUEL D'UTILISATION
MANUALE DI ISTRUZIONI**

Before operating this vehicle, please read all printed materials thoroughly. Horizon Hobby is not responsible for inadvertent errors in this manual.

HORIZON
H O B B Y

NOTICE

All instructions, warranties and other collateral documents are subject to change at the sole discretion of Horizon Hobby, LLC. For up-to-date product literature, visit www.horizonhobby.com or www.towerhobbies.com and click on the support or resources tab for this product.

MEANING OF SPECIAL LANGUAGE

The following terms are used throughout the product literature to indicate various levels of potential harm when operating this product:

WARNING: Procedures, which if not properly followed, create the probability of property damage, collateral damage, and serious injury OR create a high probability of superficial injury.

CAUTION: Procedures, which if not properly followed, create the probability of physical property damage AND a possibility of serious injury.

NOTICE: Procedures, which if not properly followed, create a possibility of physical property damage AND a little or no possibility of injury.

 **WARNING:** Read the ENTIRE instruction manual to become familiar with the features of the product before operating. Failure to operate the product correctly can result in damage to the product, personal property and cause serious injury.

This is a sophisticated hobby product. It must be operated with caution and common sense and requires some basic mechanical ability. Failure to operate this Product in a safe and responsible manner could result in injury or damage to the product or other property. This product is not intended for use by children without direct adult supervision. Do not use with incompatible components or alter this product in any way outside of the instructions provided by Horizon Hobby, LLC. This manual contains instructions for safety, operation and maintenance. It is essential to read and follow all the instructions and warnings in the manual, prior to assembly, setup or use, in order to operate correctly and avoid damage or serious injury.

 **WARNING AGAINST COUNTERFEIT PRODUCTS:** Always purchase from a Horizon Hobby, LLC authorized dealer to ensure authentic high-quality Spektrum product. Horizon Hobby, LLC disclaims all support and warranty with regards, but not limited to, compatibility and performance of counterfeit products or products claiming compatibility with DSM or Spektrum technology.

Age Recommendation: Not for children under 14 years. This is not a toy.

SAFETY PRECAUTIONS AND WARNINGS

As the user of this product, you are solely responsible for operating in a manner that does not endanger yourself and others or result in damage to the product or property of others.

This model is controlled by a radio signal subject to interference from many sources outside your control. This interference can cause momentary loss of control, so it is advisable to always keep a safe distance in all directions around your model as this margin will help avoid collisions or injury.

- Never operate your model with low transmitter batteries.
- Always operate your model in open spaces away from full-size vehicles, traffic and people.
- Never operate the model in the street or in populated areas for any reason.
- Carefully follow the directions and warnings for this and any optional support equipment (chargers, rechargeable battery packs, etc.) you use.
- Keep all chemicals, small parts and anything electrical out of the reach of children.

- Never lick or place any portion of the model in your mouth as it could cause serious injury or even death.
- Exercise caution when using tools and sharp instruments.
- Take care during maintenance as some parts may have sharp edges.
- Immediately after using your model, do NOT touch equipment such as the motor, electronic speed control and battery, because they generate high temperatures. You may burn yourself seriously touching them.
- Do not put fingers or any objects inside rotating and moving parts, as this may cause damage or serious injury.
- Always turn on your transmitter before you turn on the receiver in the car. Always turn off the receiver before turning your transmitter off.
- Keep the wheels of the model off the ground when checking the operation of the radio equipment.

WATER-RESISTANT VEHICLE WITH WATERPROOF ELECTRONICS

Your new Horizon Hobby vehicle has been designed and built with a combination of waterproof and water-resistant components to allow you to operate the product in many "wet conditions," including puddles, creeks, wet grass, snow and even rain.

While the entire vehicle is highly water-resistant, it is not completely waterproof and your vehicle should NOT be treated like a submarine. The various electronic components used in the vehicle, such as the Electronic Speed Control (ESC), servo(s) and receiver are waterproof, however, most of the mechanical components are water-resistant and should not be submerged.

Metal parts, including the bearings, hinge pins, screws and nuts, as well as the contacts in the electrical cables, will be susceptible to corrosion if additional maintenance is not performed after running in wet conditions. To maximize the long-term performance of your vehicle and to keep the warranty intact, the procedures described in the "Wet Conditions Maintenance" section below must be performed regularly if you choose to run in wet conditions. If you are not willing to perform the additional care and maintenance required, then you should not operate the vehicle in those conditions.

 **CAUTION:** Failure to exercise caution while using this product and complying with the following precautions could result in product malfunction and/or void the warranty.

GENERAL PRECAUTIONS

- Read through the wet conditions maintenance procedures and make sure that you have all the tools you will need to properly maintain your vehicle.
- Not all batteries can be used in wet conditions. Consult the battery manufacturer before use. Caution should be taken when using Li-Po batteries in wet conditions.
- Most transmitters are not water-resistant. Consult your transmitter's manual or the manufacturer before operation.
- Never operate your transmitter or vehicle where lightning may be present.
- Do not operate your vehicle where it could come in contact with salt water (ocean water or water on salt-covered roads), contaminated or polluted water. Salt water is very conductive and highly corrosive, so use caution.
- Even minimal water contact can reduce the life of your motor if it has not been certified as water-resistant or waterproof. If the motor becomes excessively wet, apply very light

throttle until the water is mostly removed from the motor. Running a wet motor at high speeds may rapidly damage the motor.

- Driving in wet conditions can reduce the life of the motor. The additional resistance of operating in water causes excess strain. Alter the gear ratio by using a smaller pinion or larger spur gear. This will increase torque (and motor life) when running in mud, deeper puddles, or any wet conditions that will increase the load on the motor for an extended period of time.

WET CONDITIONS MAINTENANCE

- Drain any water that has collected in the tires by spinning them at high speed. With the body removed, place the vehicle upside down and pull full throttle for a few short bursts until the water has been removed.

 **CAUTION:** Always keep hands, fingers, tools and any loose or hanging objects away from rotating parts when performing the above drying technique.

- Remove the battery pack(s) and dry the contacts. If you have an air compressor or a can of compressed air, blow out any water that may be inside the recessed connector housing.
- Remove the tires/wheels from the vehicle and gently rinse the mud and dirt off with a garden hose. Avoid rinsing the bearings and transmission.

NOTICE: Never use a pressure washer to clean your vehicle.

- Use an air compressor or a can of compressed air to dry the vehicle and help remove any water that may have gotten into small crevices or corners.
- Spray the bearings, drive train, fasteners and other metal parts with a water-displacing light oil. Do not spray the motor.
- Let the vehicle air dry before you store it. Water (and oil) may continue to drip for a few hours.
- Increase the frequency of disassembly, inspection and lubrication of the following:
 - Front and rear axle hub assembly bearings.
 - All transmission cases, gears and differentials.
 - Motor—clean with an aerosol motor cleaner and re-oil the bushings with lightweight motor oil.

QUICK START

Please read the entire manual to gain a full understanding of the Super Baja Rey vehicle, fine-tuning the setup and performing maintenance.

1. Read the safety precautions found in this manual.
2. Charge a battery for the vehicle. Refer to the included charging warnings and instructions for battery charging information.
3. Install the AA batteries in the transmitter. Only use alkaline or rechargeable batteries.
4. Install the fully charged battery in the vehicle.
5. Power ON the transmitter and then the vehicle. Wait 5 seconds for the ESC to initialize. Always power the transmitter ON before the vehicle and power it OFF after the vehicle has been powered OFF.
6. Check the steering and throttle control directions. Verify that the servos are moving in the correct direction.
7. Drive your vehicle.
8. Perform any necessary maintenance.

CHARGING THE BATTERY

Choose batteries designed to work with the Spektrum Firma 160A SMART Brushless ESC. We recommend standard SMART Li-Po Batteries with at least a 50C rating or higher and an IC5™ connector. Recommended 3S batteries include: Spektrum 11.1V 5000mAh 3S 50C Smart Hardcase Li-Po with IC5™ connector (SPMX50003S50H5) or Spektrum 11.1V 5000mAh 3S 100C Smart Hardcase Li-Po with IC5™ connector (SPMX50003S100H5). Recommended 4S batteries include: Spektrum 14.8v 5000mAh 4s 50C Smart Hardcase

Li-Po with IC5™ connector (SPMX50004s50H5) or Spektrum 14.8v 5000mAh 100C Smart Hardcase Li-Po with IC5™ connector (SPMX50004S100H5).

Choose a charger designed to charge Spektrum Smart Li-Po batteries. We recommend the Spektrum Smart S2100 AC Battery Charger 2 x 100w (SPMXC1010) or Spektrum Smart S1100 AC Battery Charger 1 x 100w (SPMXC1080). Refer to your battery and charger manuals for usage, safety, and charging information.

TABLE OF CONTENTS

SAFETY PRECAUTIONS AND WARNINGS	2
WATER-RESISTANT VEHICLE WITH WATERPROOF ELECTRONICS	2
QUICK START	3
CHARGING THE BATTERY	3
BOX CONTENTS	3
INSTALLING THE BATTERIES	4
TRANSMITTER FUNCTIONS	4
TRANSMITTER BATTERY INSTALLATION	4
SR6100AT AVC TECHNOLOGY TELEMETRY RECEIVER AUX CHANNELS	5
BINDING/CALIBRATING THE RECEIVER	5
DRIVING PRECAUTIONS	5
BEFORE RUNNING THE VEHICLE	5
AVC® SENSITIVITY	5
POWERING ON THE VEHICLE	6
PERFORMING A CONTROL DIRECTION TEST	6
CHANGING THE TRAVEL ADJUST SETTINGS	6
RUN TIME	7
TO IMPROVE RUN TIMES	7
POWERING OFF THE VEHICLE	7
SPEKTRUM FIRMA 750KV 4-POLE BRUSHLESS MOTOR	7
PRECAUTIONS	7
GEARING	7
CHANGING THE PINION GEAR/GEAR RATIO	7
SETTING THE GEAR MESH	7
ESC FUNCTIONS	8
SPECIFICATIONS	8
ESC LED STATUS	8
AUDIBLE WARNING TONES	8
ESC CALIBRATION PROCEDURE	8
ESC PROGRAMMING PROCEDURE	8
DESCRIPTIONS	8
TROUBLESHOOTING GUIDE	9
2-YEAR LIMITED WARRANTY	9
WARRANTY AND SERVICE CONTACT INFORMATION	10
FCC INFORMATION	10
IC INFORMATION	10
COMPLIANCE INFORMATION FOR THE EUROPEAN UNION	10
REPLACEMENT PARTS	39-40
RECOMMENDED PARTS	40
OPTIONAL PARTS	40
EXPLODED VIEWS	42-47

BOX CONTENTS

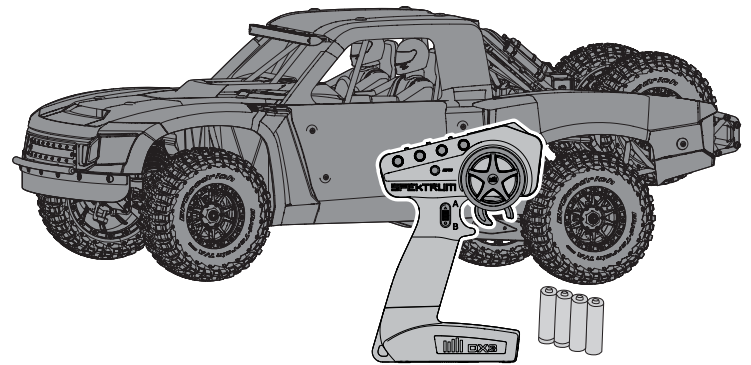

- Losi® Super Baja Rey® 2.0 RTR with SMART Technology: 1/6-Scale 4WD Desert Truck
- Spektrum™ DX3™ 2.4GHz Transmitter (SPMR2340)
- Spektrum™ SR6100AT 6 Channel AVC Telemetry Surface Receiver (SPMSR6100AT)
- Spektrum™ S905 Large Scale 40KG Waterproof Metal Gear Surface Servo, 15T (SPMS905)
- Spektrum™ Firma™ 160 Amp Brushless Smart ESC, 3S-8S (SPMXSE1160)
- Dynamite® Fuze™ 1/5 Brushless Motor, 5687 750Kv (SPMXSM2400)
- 4 AA batteries (for transmitter)

SPEKTRUM SMART TECHNOLOGY

The Super Baja Rey 2.0 includes Spektrum SMART Technology in the ESC and receiver, which can provide you with telemetry information including battery voltage and vehicle temperature. To take advantage of SMART Technology, you'll need a SMART compatible transmitter. Consider upgrading to a SMART Technology compatible Spektrum transmitter like the DX5C (SPMR5100—transmitter only), DX5 Pro (SPMR5010—transmitter only), or DX5 Rugged (SPM5200—includes SR515 receiver). Use Spektrum SMART batteries to power your vehicle to take full advantage of SMART Technology, which can communicate battery data through the SMART system as well.

Visit www.SpektrumRC.com for more information.

INSTALLING THE BATTERIES

1. Ensure the ESC is powered OFF.
2. Pull the battery door release to release the battery cover.
3. Remove the battery cover.
4. Install fully charged batteries into the vehicle.
TIP: Run the battery plugs out through the plug hole in the battery compartment.
5. Connect the batteries to the ESC.
6. Re-install the battery cover, snapping it into place. Verify the battery door release is fully seated.
7. Power ON the transmitter, then the vehicle.

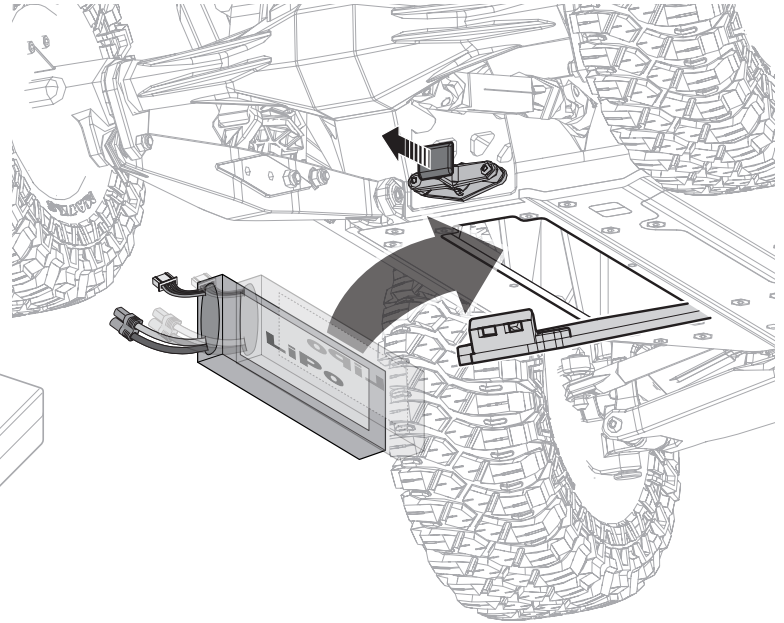
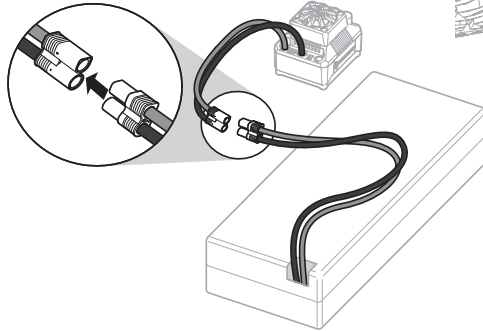

TRANSMITTER FUNCTIONS

A/B. Channel 3 Button

C. Throttle/Brake

D. Steering Wheel

E. Steering Rate

Adjusts the end point of the steering

F. Brake Rate

Adjusts the braking end point.

G. Steering Trim

Adjusts the steering center point. Normally, the steering trim is adjusted until the vehicle tracks straight.

H. Throttle Trim

Adjusts the throttle neutral point

I. SMART Battery Level Indicator

J. Servo Reversing

To reverse the Throttle (TH) or Steering (ST) channel, switch the position of the correlating switch—"N" is for normal, "R" is for reverse.

K. Throttle Limit

Limits throttle output to 50/75/100%

Select 50% or 75% for less experienced drivers or when you are driving the vehicle in a small area.

L. Power LED

- **Solid red lights:** Indicates radio connectivity and adequate battery power
- **Flashing red lights:** Indicates the battery voltage is critically low. Replace batteries

M. Power Button

N. Bind Button

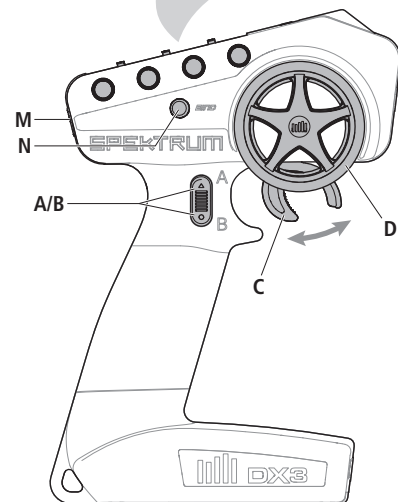
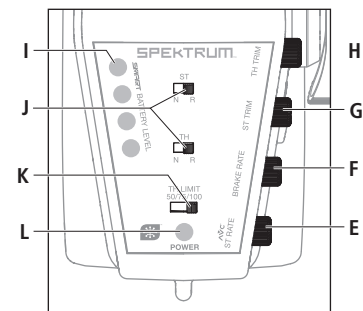

TRANSMITTER BATTERY INSTALLATION

This transmitter requires 4 AA batteries

1. Remove the battery cover from the transmitter.
2. Install the batteries as shown.
3. Install the battery cover.

- ⚠ **CAUTION:** Never remove the transmitter batteries while the model is powered ON. Loss of model control, damage, or injury may occur.
- ⚠ **CAUTION:** If using rechargeable batteries, charge only rechargeable batteries. Charging non-rechargeable batteries may cause the batteries to burst, resulting in injury to persons and/or damage to property.
- ⚠ **CAUTION:** Risk of explosion if battery is replaced by an incorrect type. Dispose of used batteries according to national regulations.

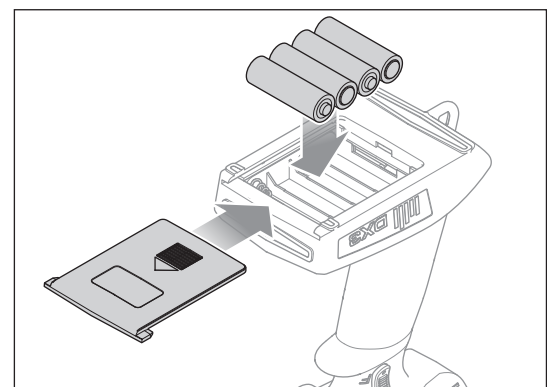

SR6100AT AVC TECHNOLOGY TELEMETRY RECEIVER

AUX CHANNELS

The Aux channels can operate as additional servo channels, or as a power supply for a personal transponder.

If AVC is active, only 4 channels; Steering, Throttle, AUX3 and AUX4 are operational. The remaining Aux channels can be used to power a personal transponder or lights.

If AVC is disabled (see **DISABLING AVC TECHNOLOGY STABILITY ASSIST FUNCTION**), all 6 channels including the Aux channels can operate as servo channels.

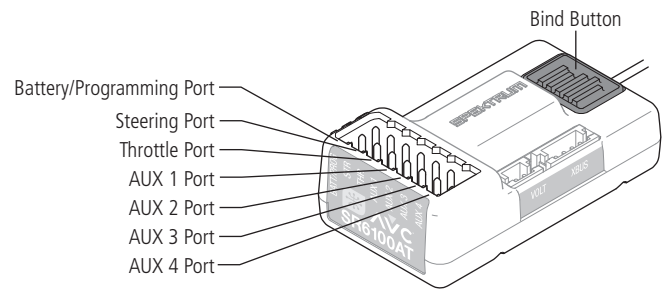

BINDING AND CALIBRATING THE RECEIVER

Binding is the process of linking the SR6100AT receiver to your Spektrum transmitter. The AVC features on the receiver can be enabled or disabled during the binding process.

IMPORTANT: You must calibrate the SR6100AT receiver each time it is placed in bind mode, regardless of AVC being enabled or disabled.

Upon initial setup after the first bind, the model must be configured for servo direction, trim and travel. Then the receiver must be rebound and calibrated to those settings for proper operation. Center the steering trim and throttle trim on the transmitter before beginning.

1. Press and hold the bind button on the receiver.
2. Power on the receiver. The orange LED flashes, indicating the receiver is in bind mode. Release the bind button after the orange LED illuminates.
3. Put your transmitter in bind mode. The bind process is complete when the orange LED on the receiver remains lit. The receiver is now bound to the transmitter but must be calibrated before it will operate.
4. Pull the transmitter trigger to full throttle, pause, then return the trigger to center.

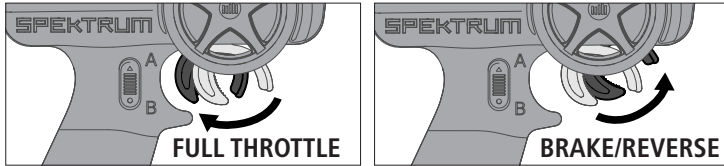

5. Push the transmitter trigger to full brake, pause, then return the trigger to center.
6. Turn the transmitter steering wheel to full right, pause, then return the wheel to center.
7. Turn the transmitter steering wheel to full left, pause, then return the steering wheel to center. The orange LED flashes to confirm the settings have been accepted.
8. Turn off the vehicle to complete the binding and calibration process.

CAUTION: When the bind process is complete, the throttle and steering channels are active. Keep hands and loose objects away from all spinning parts on the vehicle.

IMPORTANT: You must rebind the transmitter and receiver if you:

- Change the servo reversing after binding
- Change the travel after binding
- Change the receiver mounting orientation

DISABLING AVC® TECHNOLOGY STABILITY ASSIST

If you participate in organized racing, you may be required to turn AVC technology off.

To turn off AVC technology:

1. Connect power to the receiver and quickly press and release the bind button three times (within 1.5 seconds).
2. Press and hold the bind button and to put the receiver in bind mode. Release the button when the LED starts to flash rapidly, indicating it is in bind mode.

When the AVC system has been disabled, the LED on the receiver will show three flashes upon power up, and then remain lit. The receiver is bound and operating normally when the LED remains illuminated.

TIP: If the AVC feature in the receiver is active and the AVC menu in the transmitter is inhibited, AVC functions will default to the AUX 1 and AUX 2 operation, and in this scenario, AVC will not work correctly.

FAILSAFE

In the unlikely event that the radio link is lost during use, the receiver will drive the throttle channel to the neutral position. If the receiver is powered on prior to turning on the transmitter, the receiver will enter the failsafe mode, driving the throttle channel to the neutral position. When the transmitter is turned on, normal control is resumed.

IMPORTANT: Failsafe activates only in the event that signal is lost from the transmitter. Failsafe will NOT activate in the event that receiver battery power decreases below the recommended minimums or power to the receiver is lost.

DRIVING PRECAUTIONS

- Maintain sight of the vehicle at all times.
- Routinely inspect the vehicle for loose wheel hardware.
- Routinely inspect the steering assembly for any loose hardware. Driving the vehicle off-road can cause fasteners to loosen over time.
- Do not drive the vehicle in tall grass. Doing so can damage the vehicle or electronics.
- Stop driving the vehicle when you notice a lack of power. Driving the vehicle when the battery is discharged can cause the receiver to power off. If the receiver loses power, you will lose control of the vehicle. Damage due to an over-discharged Li-Po battery is not covered under warranty.

CAUTION: Do not discharge a Li-Po battery below 3V per cell. Batteries discharged to a voltage lower than the lowest approved voltage may become damaged, resulting in loss of performance and potential fire when batteries are charged.

- Do not apply forward or reverse throttle if the vehicle is stuck. Applying throttle in this instance can damage the motor or ESC.
- After driving the vehicle, allow the electronics to cool before driving the vehicle again.

IMPORTANT: Keep wires away from all moving parts.

BEFORE RUNNING THE VEHICLE

1. Check for free suspension movement. All suspension arms and steering components should move freely. Any binds will cause the vehicle to handle poorly.

TIP: To increase the ride height and ground clearance of your vehicle, screw down the shock collars to compress the springs.

2. Charge a battery pack. Always charge the battery pack as per the battery and/or charger manufacturers' instructions.
3. Set the transmitter steering trim. Follow the instructions to set the steering trim/subtrim so that the vehicle drives straight with no input to the steering.
4. Perform a Control Direction Test.

AVC® SENSITIVITY

The ST RATE dial adjusts the sensitivity, or stability, value in the receiver. If you increase the sensitivity, the AVC® system becomes more sensitive to the vehicle drifting left or right. You would use maximum sensitivity during high speed driving or drag racing, when you want the vehicle to stay in a straight line.



Turn the ST RATE knob counter-clockwise to reduce the sensitivity.

Turn the ST RATE knob clockwise to increase the sensitivity.

IMPORTANT: The ST RATE knob will only adjust the sensitivity when the transmitter is bound to a DSMR® receiver. When the transmitter is bound to a DSM®, DSM2® or DSM Marine receiver, the ST RATE knob controls the steering dual rate.

POWERING ON THE VEHICLE

1. Center the ST TRIM and TH TRIM dials on the transmitter.
2. Power on the transmitter.
3. Connect the fully charged battery packs to the ESC.
4. Power on the ESC.

IMPORTANT: The vehicle **MUST** remain on a flat, level surface and motionless for at least 5 seconds.

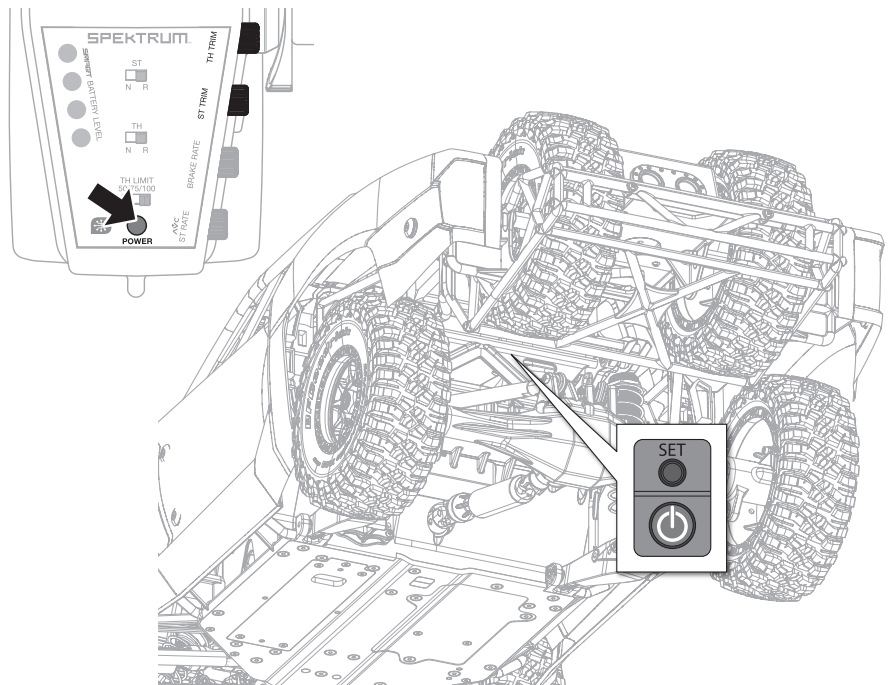

PERFORMING A CONTROL DIRECTION TEST

Perform a control test with the vehicle wheels off the ground. If the wheels rotate after the vehicle is powered ON, adjust the TH Trim knob until they stop. To make the wheels move forward, pull the trigger. To reverse them, wait for the wheels to stop, then push the trigger. When moving forward, the wheels should maintain a straight line without any steering wheel input. If not, adjust the ST Trim knob, so the wheels maintain a straight line without having to turn the steering wheel.

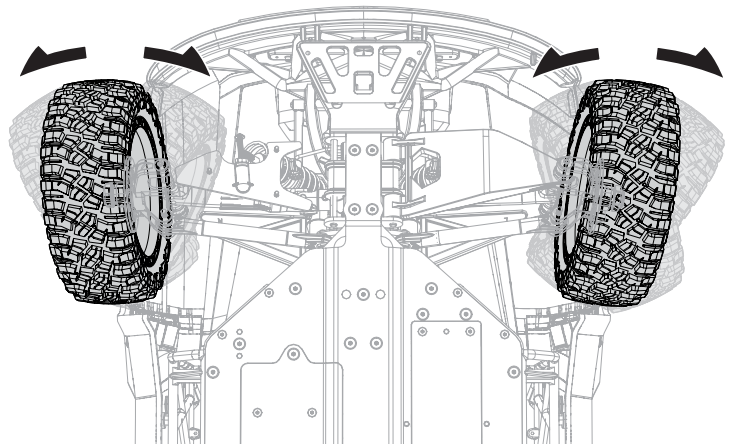

CHANGING THE TRAVEL ADJUST SETTINGS

1. Hold the trigger in the full brake position and turn the steering wheel to Full Right while powering on the transmitter. The LED flashes blue, indicating the programming mode is active.
2. Throttle End Point: Continue holding full throttle. Turn the BRAKE RATE ADJUST knob to adjust the full throttle end point.
3. Brake End Point: Hold the trigger in the full brake position. Turn the BRAKE RATE ADJUST knob to adjust the full brake end point. Return the trigger to the center position.
4. Left Steering End Point: Hold the steering wheel in the full left position. Turn the AVC ST RATE knob to adjust the left end point.
5. Right Steering End Point: Hold the steering wheel in the full right position. Turn the AVC ST RATE knob to adjust the right end point. Return the steering wheel to the center position.
6. Power off the transmitter to save the travel adjust settings.
The minimum Travel is 75%, and the Maximum travel is 150%.

IMPORTANT: If the travel is changed on the DX3, you must rebind and calibrate the receiver.

RUN TIME

The largest factor in run time is the capacity of the battery pack. A larger mAh rating increases the amount of run time experienced.

The condition of a battery pack is also an important factor in both run time and speed. The battery connectors may become hot during driving. Batteries will lose performance and capacity over time.

Driving the vehicle from a stop to full speed repeatedly will damage the batteries and electronics over time. Sudden acceleration will also lead to shorter run times.

TO IMPROVE RUN TIMES

- Keep your vehicle clean and well maintained.
- Allow more airflow to the ESC and motor.
- Change the gearing to a lower ratio. A lower ratio decreases the operating temperature of the electronics. Use a smaller pinion gear or larger spur gear to lower the gear ratio.
- Use a battery pack with a higher mAh rating.
- Use the optimum charger to charge battery packs (Visit your local hobby dealer for more information).

POWERING OFF THE VEHICLE

1. Power off the ESC.
2. Power off the transmitter.
3. Remove and charge the batteries.

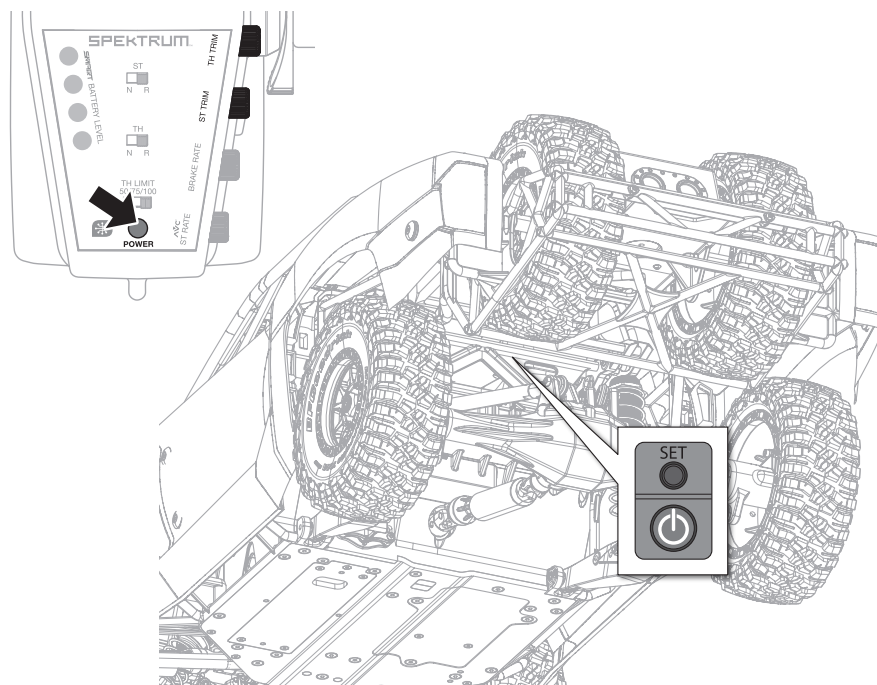

SPEKTRUM FIRMA 750KV 4-POLE BRUSHLESS MOTOR

PRECAUTIONS

- Never touch moving parts.
- Never disassemble while the batteries are installed.
- Always let parts cool before touching.

GEARING

Your vehicle has been equipped with the optimal gearing for the stock platform. It offers an ideal balance between speed, power and efficiency. Should you decide to customize your vehicle with optional batteries or motors, it may be necessary for you to change the pinion or spur gear.

Installing a pinion gear with fewer teeth or a spur gear with more teeth will provide greater torque but will reduce top speed. Likewise, a pinion gear with more teeth or a spur gear with fewer teeth will reduce torque and increase top speed. Care should be taken when installing larger pinion gears as this can "overgear" the vehicle, resulting in overheating of the motor and ESC. When testing different gearing options, pay close attention to the temperature of the motor and speed control to ensure you are operating within the temperature range of the components. The motor or ESC should never be so hot that it cannot be touched. If temperatures are too hot, a different gearing combination with a lower pinion gear and/or higher spur gear is suggested.

CHANGING THE PINION GEAR/GEAR RATIO

The Super Baja Rey 2.0 uses a motor mount with pre-set gearing from 16-24T.

1. Remove the lower motor mount chassis plate, the motor, and motor mount.
2. Loosen the set screw and remove the installed pinion gear.
3. Install the motor screws corresponding to the number of teeth on the pinion gear.
4. Place the new pinion gear on the end of the motor shaft, so the setscrew is located over the flat of the shaft.
5. Position the pinion gear so that the teeth line up with the spur gear and secure the pinion gear by tightening the set screw.
6. Check the gear mesh to ensure that everything spins properly.

SETTING THE GEAR MESH

The motor gearing is set on the motor mount and uses corresponding holes that match the number of teeth on the pinion gear. The gear mesh has already been set at the factory. Setting it is only necessary when changing motors or gears.

Proper gear mesh (how gear teeth meet) is important to the performance of the vehicle. When the gear mesh is too loose, the pinion gear can damage the spur gear. If the mesh is too tight, speed could be limited and the motor and ESC will overheat.

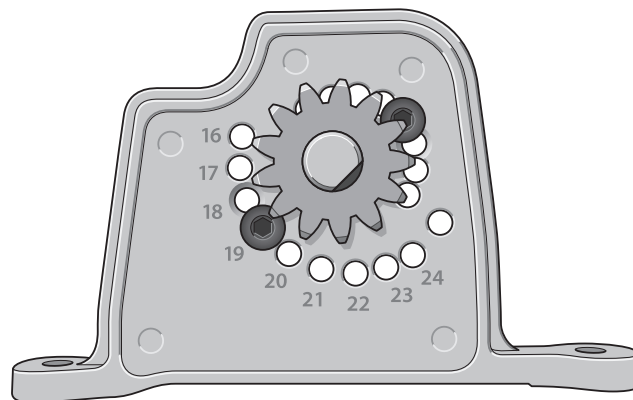

IMPORTANT: The included 19T pinion gear is suitable for use with 6S or 8S Li-Po batteries.

NOTICE: For extreme load surfaces (e.g., sand and tall grass), gear down 1–2 teeth on the pinion gear to minimize the chance of motor and ESC damage.

ESC FUNCTIONS

SPECIFICATIONS

Type	Sensorless
Constant/Peak	160A/1050A
Resistance	0.00020hm
Function	Forward with Brake, Forward/Reverse with Brake
Operation	Proportional forward, proportional reverse with braking
Input Voltage	3–8s LiPo
BEC Output	6V/8.4V, 6A
Overload Protection	Motor Lock-up protection, Low-voltage cutoff protection, Thermal protection, Overload protection and fail safe (throttle signal loss protection)
Dimensions (LxWxH)	70mm x 65mm x 45.5mm
Weight	288g

ESC LED STATUS

- No ESC LEDs will glow when there is no throttle input from the transmitter.
- The red ESC LED glows when there is any throttle input from the transmitter.

AUDIBLE WARNING TONES

- Input Voltage:** The ESC checks the input voltage when it is powered ON. If a voltage problem is detected, the ESC continuously sounds 2 beeps with a 1 second pause (xx-xx-xx). Power OFF the ESC and ensure the connections are secure and that the battery power is not too low for safe operation.
- Radio Connection:** The ESC checks radio signal input when it is powered ON. If a problem is detected, the ESC continuously sounds 1 beep with a 2 second pause (x--x--x). Power OFF the ESC and ensure the radio system is operating correctly.

ESC CALIBRATION PROCEDURE

Ensure proper ESC function by calibrating the ESC to your transmitter inputs.

- Power OFF the ESC.
- Ensure your transmitter is powered ON, the throttle is not reversed, the throttle trim is neutral and the throttle travel range is at 100%. Disable any special functions such as ABS, etc.
- Press the SET button while powering ON the ESC. Release the button as soon as the red LED starts to flash.
- Calibrate the throttle points by pressing the SET button once after each step.
 - Neutral (1 flash)—leave the throttle at rest, untouched
 - Full throttle (2 flashes)—pull the throttle fully back
 - Full brake/reverse (3 flashes)—push the throttle fully forward
- The motor will run 3 seconds after the last step is completed.

TIP: If the motor turns in the wrong direction, reverse the connection of any 2 outside motor wires. The center wire must remain in the center and cannot be moved to another motor tab.



ESC PROGRAMMING PROCEDURE

- Connect a fully charged battery to the ESC.
- Power ON the ESC using the ESC switch.
- Hold the SET button for 1 second until the GREEN LED blinks, then release the SET button to enter programming mode.
- Press and release the SET button as needed to get to the desired menu option (the GREEN LED will blink corresponding to the menu item number). Programming menu items 1 through 6 are accessible using the SET button on the ESC.
- When at the desired menu item, hold the SET button for 3 seconds until the RED LED blinks.
- Press the SET button to move among the settings based on how many times the RED LED blinks (Refer to the table for more information).
- Save the setting by holding the SET button for 3 seconds.
- Power OFF the ESC switch and repeat the instructions above to change other settings.

The black-shaded setting is the factory default.

PROGRAMMABLE ITEMS	PROGRAMMABLE VALUE								
	1	2	3	4	5	6	7	8	9
1 Running Mode	Forward with Brake	Forward/ Reverse with Brake							
2 Motor Rotation	CCW	CW							
3 Li-Po Cells	Auto Calc.	3s	4s	6s	8s				
4 Voltage Cutoff	Auto (Low)	Auto (Medium)	Auto (High)						
5 BEC Voltage	6.0V	8.4V							
6 Max Brake Force	25%	37.5%	50%	62.5%	75%	87.5%	100%	Disabled	
7 Max Reverse Force	25%	50%	75%	100%					
8 Punch Setting	Level 1	Level 2	Level 3	Level 4	Level 5				
9 Timing	0°	3.75°	7.5°	11.25°	15°				

DESCRIPTIONS

1. Running Mode

- Forward Only with Brake**
Intended for competition use, this mode allows only forward and brake controls.
- Forward/Reverse with Brake**
This mode is the basic all-around mode, allowing forward, reverse and brake controls. To engage reverse while moving forward, apply the brake until the vehicle has come to a complete stop, release brake, then apply the brake again. While braking or in reverse, engaging the throttle will result in the vehicle immediately accelerating forward.

2. Motor Rotation

Allows you to electronically set the rotation of the motor without changing any of the wires from the motor to the ESC.

3. Li-Po Cells

The default setting is **Auto Calc**, which will automatically select the detected number of cells. Select value 2–5 to manually select a cell count from 3–8 cells.

4. Low Voltage Cutoff

This function helps to prevent battery over-discharge. The ESC continuously monitors the battery's voltage. If the voltage falls below the voltage threshold for 2 seconds, the output power shuts off and the red LED flashes twice repeatedly.

The cutoff threshold calculation is based on individual Li-Po cell voltage. For Ni-MH batteries, if the voltage battery pack is higher than 9.0V, it will be treated as a 3-cell Li-Po battery pack; if it is lower than 9.0V, it will be treated as a 2-cell Li-Po battery pack. Example: for a 8.0V Ni-MH battery pack used with a 2.6V/cell threshold, it will be treated as a 2-cell Li-Po battery pack and the low-voltage cut-off threshold will be 5.2V (2.6x2=5.2).

5. Bec Voltage

Select either 6 or 8.4 V to run the receiver and servos.

6. Max Brake Force

Adjusts the maximum braking force. A higher value provides stronger braking, but can also cause the wheels to lock, resulting in loss of control of the car.

7. Max Reverse Force

This parameter adjusts the maximum power when travelling in reverse.

8. Punch Setting

Sets the initial throttle punch when the car accelerates. Level 1 gives a very soft initial acceleration and level 5 gives a stronger initial acceleration.

9. Timing

Allows for timing value selection according to your motor. Generally, higher timing value brings out higher power output, but the efficiency of the system will be slightly lower with possible increases in motor and ESC running temperatures.

TROUBLESHOOTING GUIDE

PROBLEM	POSSIBLE CAUSE	SOLUTION
Vehicle does not operate	Battery not charged or plugged in	Charge battery/plug in
	ESC switch not "On"	Turn on ESC switch
	Transmitter not "On" or low battery	Turn on/replace batteries
Motor runs but wheels do not rotate	Pinion not meshing with spur gear	Adjust pinion/spur mesh
	Pinion spinning on motor shaft	Tighten pinion gear setscrew on motor shaft flat spot
	Transmission gears stripped	Replace transmission gears
	Drive pin broken	Check and replace drive pin
Steering does not work	Servo plug not in receiver properly	Make sure the steering servo plug is connected to the receiver steering channel, noting proper polarity
	Servo gears or motor damaged	Replace or repair servo
Will not turn one direction	Servo gears damaged	Replace or repair servo
Motor does not run	Motor wires not connected properly	Check bullet connectors for proper fit
	Motor wire broken	Repair or replace as needed
	ESC damaged	Contact Horizon Hobby Product Support
ESC gets hot	Motor over-gear	Use smaller pinion or larger spur gear
	Driveline bound up	Check wheels and transmission for binding
Poor run time and/or sluggish acceleration	Battery pack not fully charged	Recharge battery
	Charger not allowing full charge	Try another charger
	Driveline bound up	Check wheels, transmission for binding
Poor range and/or glitching	Transmitter batteries low	Check and replace
	Vehicle battery low	Recharge battery
	Loose plugs or wires	Check all wire connections and plugs

2-YEAR LIMITED WARRANTY

What this Warranty Covers

Horizon Hobby, LLC, (Horizon) warrants to the original purchaser that the product purchased (the "Product") will be free from defects in materials and workmanship for two years from the date of purchase.

What is Not Covered

This warranty is not transferable and does not cover (i) cosmetic damage, (ii) damage due to acts of God, accident, misuse, abuse, negligence, commercial use, or due to improper use, installation, operation or maintenance, (iii) modification of or to any part of the Product, (iv) attempted service by anyone other than a Horizon Hobby authorized service center, (v) Product not purchased from an authorized Horizon dealer, (vi) Product not compliant with applicable technical regulations, or (vii) use that violates any applicable laws, rules, or regulations.

OTHER THAN THE EXPRESS WARRANTY ABOVE, HORIZON MAKES NO OTHER WARRANTY OR REPRESENTATION, AND HEREBY DISCLAIMS ANY AND ALL IMPLIED WARRANTIES, INCLUDING, WITHOUT LIMITATION, THE IMPLIED WARRANTIES OF NON-INFRINGEMENT, MERCHANTABILITY AND FITNESS FOR A PARTICULAR PURPOSE. THE PURCHASER ACKNOWLEDGES THAT THEY ALONE HAVE DETERMINED THAT THE PRODUCT WILL SUITABLY MEET THE REQUIREMENTS OF THE PURCHASER'S INTENDED USE.

Purchaser's Remedy

Horizon's sole obligation and purchaser's sole and exclusive remedy shall be that Horizon will, at its option, either (i) service, or (ii) replace, any Product determined by Horizon to be defective. Horizon reserves the right to inspect any and all Product(s) involved in a warranty claim. Service or replacement decisions are at the sole discretion of Horizon. Proof of purchase is required for all warranty claims. SERVICE OR REPLACEMENT AS PROVIDED UNDER THIS WARRANTY IS THE PURCHASER'S SOLE AND EXCLUSIVE REMEDY.

Limitation of Liability

HORIZON SHALL NOT BE LIABLE FOR SPECIAL, INDIRECT, INCIDENTAL OR CONSEQUENTIAL DAMAGES, LOSS OF PROFITS OR PRODUCTION OR COMMERCIAL LOSS IN ANY WAY, REGARDLESS OF WHETHER SUCH CLAIM IS BASED IN CONTRACT, WARRANTY, TORT, NEGLIGENCE, STRICT LIABILITY OR ANY OTHER THEORY OF LIABILITY, EVEN IF HORIZON HAS BEEN ADVISED OF THE POSSIBILITY OF SUCH DAMAGES. Further, in no event shall the liability of Horizon exceed the individual price of the Product on which liability is asserted. As Horizon has no control over use, setup, final assembly, modification or misuse, no liability shall be assumed nor accepted for any resulting damage or injury. By the act of use, setup or assembly, the user accepts all resulting liability. If you as the purchaser or user are not prepared to accept the liability associated with the use of the Product, purchaser is advised to return the Product immediately in new and unused condition to the place of purchase.

Law

These terms are governed by Illinois law (without regard to conflict of law principals). This warranty gives you specific legal rights, and you may also have other rights which vary from state to state. Horizon reserves the right to change or modify this warranty at any time without notice.

WARRANTY SERVICES

Questions, Assistance, and Services

Your local hobby store and/or place of purchase cannot provide warranty support or service. Once assembly, setup or use of the Product has been started, you must contact your local

distributor or Horizon directly. This will enable Horizon to better answer your questions and service you in the event that you may need any assistance. For questions or assistance, please visit our website at www.horizonhobby.com, submit a Product Support Inquiry, or call the toll free telephone number referenced in the Warranty and Service Contact Information section to speak with a Product Support representative.

Inspection or Services

If this Product needs to be inspected or serviced and is compliant in the country you live and use the Product in, please use the Horizon Online Service Request submission process found on our website or call Horizon to obtain a Return Merchandise Authorization (RMA) number. Pack the Product securely using a shipping carton. Please note that original boxes may be included, but are not designed to withstand the rigors of shipping without additional protection. Ship via a carrier that provides tracking and insurance for lost or damaged parcels, as Horizon is not responsible for merchandise until it arrives and is accepted at our facility. An Online Service Request is available at http://www.horizonhobby.com/content/service-center_render-service-center. If you do not have internet access, please contact Horizon Product Support to obtain a RMA number along with instructions for submitting your product for service. When calling Horizon, you will be asked to provide your complete name, street address, email address and phone number where you can be reached during business hours. When sending product into Horizon, please include your RMA number, a list of the included items, and a brief summary of the problem. A copy of your original sales receipt must be included for warranty consideration. Be sure your name, address, and RMA number are clearly written on the outside of the shipping carton.

NOTICE: Do not ship LiPo batteries to Horizon. If you have any issue with a LiPo battery, please contact the appropriate Horizon Product Support office.

Warranty Requirements

For Warranty consideration, you must include your original sales receipt verifying the proof-of-purchase date. Provided warranty conditions have been met, your Product will be serviced or replaced free of charge. Service or replacement decisions are at the sole discretion of Horizon.

Non-Warranty Service

Should your service not be covered by warranty, service will be completed and payment will be required without notification or estimate of the expense unless the expense exceeds 50% of the retail purchase cost. By submitting the item for service you are agreeing to payment of the service without notification. Service estimates are available upon request. You must include this request with your item submitted for service. Non-warranty service estimates will be billed a minimum of 1/2 hour of labor. In addition you will be billed for return freight. Horizon accepts money orders and cashier's checks, as well as Visa, MasterCard, American Express, and Discover cards. By submitting any item to Horizon for service, you are agreeing to Horizon's Terms and Conditions found on our website http://www.horizonhobby.com/content/service-center_render-service-center.

ATTENTION: Horizon service is limited to Product compliant in the country of use and ownership. If received, a non-compliant Product will not be serviced. Further, the sender will be responsible for arranging return shipment of the un-serviced Product, through a carrier of the sender's choice and at the sender's expense. Horizon will hold non-compliant Product for a period of 60 days from notification, after which it will be discarded.

WARRANTY AND SERVICE CONTACT INFORMATION

Country of Purchase	Horizon Hobby	Contact Information	Address
United States of America	Horizon Service Center (Repairs and Repair Requests)	servicecenter.horizonhobby.com/RequestForm/	2904 Research Rd. Champaign, Illinois 61822 USA
	Horizon Product Support (Product Technical Assistance)	productsupport@horizonhobby.com 877-504-0233	
	Sales	websales@horizonhobby.com 800-338-4639	
EU	Horizon Technischer Service Sales: Horizon Hobby GmbH	service@horizonhobby.eu +49 (0) 4121 2655 100	Hanskampring 9 D 22885 Barsbüttel, Germany

FCC INFORMATION

Contains FCC ID: BRWKATY1T | BRWSR6100AT

This equipment complies with FCC and IC radiation exposure limits set forth for an uncontrolled environment. This equipment should be installed and operated with minimum distance 20cm between the radiator and/or antenna and your body (excluding fingers, hands, wrists, ankles and feet). This transmitter must not be co-located or operating in conjunction with any other antenna or transmitter.

Supplier's Declaration of Conformity

Losi Super Baja Rey 2.0, RTR (LOS05021)

This device complies with part 15 of the FCC Rules. Operation is subject to the following

FCC two conditions: (1) This device may not cause harmful interference, and (2) this device must accept any interference received, including interference that may cause undesired operation.

CAUTION: Changes or modifications not expressly approved by the party responsible for compliance could void the user's authority to operate the equipment.

NOTE: This equipment has been tested and found to comply with the limits for a Class B digital device, pursuant to part 15 of the FCC Rules. These limits are designed to provide reasonable protection against harmful interference in a residential installation.

This equipment generates, uses and can radiate radio frequency energy and, if not installed and used in accordance with the instructions, may cause harmful interference to radio communications. However, there is no guarantee that interference will not occur in a particular installation. If this equipment does cause harmful interference to radio or television reception, which can be determined by turning the equipment off and on, the user is encouraged to try to correct the interference by one or more of the following measures:

- Reorient or relocate the receiving antenna.
- Increase the separation between the equipment and receiver.
- Connect the equipment into an outlet on a circuit different from that to which the receiver is connected.
- Consult the dealer or an experienced radio/TV technician for help.

Horizon Hobby, LLC
2904 Research Rd., Champaign, IL 61822
Email: compliance@horizonhobby.com
Web: HorizonHobby.com

IC INFORMATION

CAN ICES-3 (B)/NMB-3(B)

Contains IC: 6157A-KATY1T

6157A-SR6100AT

This device contains license-exempt transmitter(s)/receivers(s) that comply with Innovation, Science, and Economic Development Canada's license-exempt RSS(s). Operation is subject to the following 2 conditions:

1. This device may not cause interference.
2. This device must accept any interference, including interference that may cause undesired operation of the device.

COMPLIANCE INFORMATION FOR THE EUROPEAN UNION



EU Compliance Statement:

Losi Super Baja Rey 2.0, RTR (LOS05021)

Hereby, Horizon Hobby, LLC declares that the device is in compliance with the following: EU Radio Equipment Directive (RED) 2014/53/EU; RoHS 2 Directive

2011/65/EU; RoHS 3 Directive - Amending 2011/65/EU Annex II 2015/863.

The full text of the EU declaration of conformity is available at the following internet address: <https://www.horizonhobby.com/content/support-render-compliance>.

NOTE: This product contains batteries that are covered under the 2006/66/EC European Directive, which cannot be disposed of with normal household waste. Please follow local regulations.

Wireless Frequency Range and Wireless Output Power:

Transmitter:

2402–2478MHz

17.7 dBm

Receiver:

2404–2476MHz

19.39dBm

EU Manufacturer of Record:

Horizon Hobby, LLC
2904 Research Road
Champaign, IL 61822 USA

EU Importer of Record:

Horizon Hobby, GmbH
Hanskampring 9
22885 Barsbüttel Germany

WEEE NOTICE:



This appliance is labeled in accordance with European Directive 2012/19/EU concerning waste of electrical and electronic equipment (WEEE). This label indicates that this product should not be disposed of with household waste. It should be deposited at an appropriate facility to enable recovery and recycling.



Replacement Parts // Ersatzteile // Pièces de rechange // Pezzi di ricambio

Part #	English	Deutsch	Français	Italiano
LOS235007	Button Head Screw, M3 x 12mm (10)	Rundkopfschraube, M3 x 12mm (10)	Vis à tête bombée M3 x 12 mm (10)	Viti a bottone, M3 x 12 mm (10)
LOS235009	Flat Head Screw, M2.5 x 8mm (10)	Flachkopfschraube M2,5 x 8mm (10)	Vis à tête plate M2,5 x 8 mm (10)	Viti a testa piana, M2.5 x 8 mm (10)
LOS235012	Set Screw, M4 x 4mm Cup Point (10)	Stellschraube M4 x 4mm Ringschneide (10)	Vis de fixation M4 x 4 mm Bout cuvette (10)	Kit viti, M4 x 4 mm, senza testa (10)
LOS235025	Button Head Screw, M3 x 30mm (10)	Rundkopfschraube, M3 x 30mm (10)	Vis à tête bombée M3 x 30 mm (10)	Viti a bottone, M3 x 30 mm (10)
LOS236001	Washer, 3.2mm x 7mm x .5mm (10)	Unterlegscheibe, 3,2mm x 7mm x 0,5mm (10)	Rondelle, 3,2 mm x 7 mm x 5 mm (10)	Rondelle 3,2 x 7 x 0,5 mm (10)
LOS250022	Body Button Set (22)	Satz Body Buttons (22)	Ensemble de boutons de carrosserie (22)	Anelli di protezione della carrozzeria (22)
LOS250042	Driver Helmet (2)	Fahrerhelm (2)	Casque de conducteur (2)	Caschi pilota (2)
LOS250045	Front Skip Plate and Support Brace	Vornegleitplatte und Stützstrebe	Plaque de protection avant et renfort de support	Supporto e piastra di protezione ant.
LOS250046	Body and Front Grill, Clear	Gehäuse und Vornegrill, Transparent	Grille de carrosserie et avant, transparent	Griglia ant. e carrozzeria, trasparente
LOS250047	Interior Set w/Helmets, Clear	Interieurset mit Helmen, Transparent	Ensemble d'intérieur avec casques, transparent	Kit abitacolo con caschi, trasparente
LOS250048	Body and Front Grill, Brenthel	Gehäuse und Vornegrill, Brenthel	Grille de carrosserie et avant, Brenthel	Griglia ant. e carrozzeria, Brenthel
LOS250049	Body and Front Grill, King	Gehäuse und Vornegrill, King	Grille de carrosserie et avant, King	Griglia ant. e carrozzeria, King
LOS251059	Steering Servo Mount & Bellcrank Set	Lenkservo-Halterung & Umlenkhebelset	Support servo de direction et ensemble de leviers	Kit squadretta e supporto servo dello sterzo
LOS251060	Rear Chassis Brace/ESC Mount	Hintere Karosseriestrebe/Halterung Geschwindigkeitsregler	Support de carrosserie arrière/ support de variateur ESC	Rinforzo post. telaio/supporto ESC
LOS251062	Center Brace & Stand Offs	Mittelstrebe und Standoffs	Support central et entretoises	Rinforzo centrale e distanziatori
LOS251063	LED Light Bar, Front	LED-Lichtstange, Vorne	Barre d'éclairage à DEL, avant	Barra a LED ant.
LOS251064	LED Light Bar, Rear	LED-Lichtstange, Hinte	Barre d'éclairage à DEL, arrière	Barra a LED post.
LOS251065	Steering Hardware Set	Hardwaresatz Lenkung	Ensemble de matériel de direction	Set accessori sterzo
LOS251066	Steering Servo Arm, 15T	Servolenkarm, 15T	Bras de servo de direction, 15T	Braccio servo sterzo, 15T
LOS251067	Steering Tie Rods (2)	Lenkung Zuganker (2)	Barres d'accouplement de direction (2)	Barre di accoppiamento (2)
LOS251080	Battery Tray	Akkufach	Support de pile	Supporto batteria
LOS251081	Battery Tray Hardware Set	Akkualterung Hardwaresatz	Ensemble de matériel de support de batterie	Kit accessori supporto batteria
LOS251083	Chassis, Motor & Battery Cover Plates	Karosserie, Motor- & Akku-Abdeckplatten	Carrosserie, moteur et plaques de couverture de batterie	Coperchi telaio, batteria, motore
LOS251104	IC5 Battery Plug Holder	IC5-Akku Steckerhalter	Porte-prise de batterie IC5	Porta-spina batteria IC5
LOS251105	Front Bumper and Rubber Valance	Vornestoßstange und Gummischürze	Pare-chocs avant et jupe en caoutchouc	Gomma e paraurti ant. Valance
LOS251106	Front Skid Plate & Brace	Front Gleitplatte und verstärkung	Plaque de protection et renfort avant	Piastra paramotore e rinforzo, anteriore
LOS251107	Front Mud Guards (L/R)	Vorneschmutzfänger (L/R)	Garde-boues avant (L/R)	Parafanghi ant. (SX/DX)
LOS251108	Roll Cage Sides (L/R)	Überrollkäfigseiten (L/R)	Cage de retournement (L/R)	Scocca di protezione, fianchi (SX/DX)
LOS251109	Roll Cage Front and Front Top Bar	Überrollkäfig Vorne und Obere Vornestange	Cage de retournement avant et barre supérieure avant	Scocca di protezione, barra ant. e superiore ant.
LOS251110	Cage Roof and Spare Tire Holder	Käfigdach und Ersatzradhalter	Toit de cage et porte-pneu de secours	Tetto scocca di protezione e portaruota di scorta
LOS251111	Rear Cage	Hintekäfig	Cage arrière	Scocca di protezione, post.
LOS251112	Cage Accessories	Käfigzubehör	Accessoires de cage	Accessori scocca
LOS252042	Pinion Gear, 19T, 8mm Shaft, 1.5M	Zahnradgetriebe, 19T, 8 mm Welle, 1.5M	Engrenage à pignons, 19T, arbre de 8 mm, 1,5 M	Pignone, 19T, albero 8 mm, 1,5 m
LOS252069	Diff Housing and Gasket	Differentialgehäuse und Dichtung	Boîtier de différentiel et joint	Carcassa diff. e guarnizione
LOS252070	Diff Rebuild Kit	Differentialgetriebe-Umbau-Kit	Kit de reconstruction de différentiel	Kit ricostruzione differenziale
LOS252071	Axle Housing Set, Rear	Achsgehäuse-Set, Hinte	Ensemble de carter d'essieu, arrière	Kit carcassa assale, post.
LOS252073	Center Transmission Housing	Zentrales Getriebegehäuse	Boîtier de vitesse centrale	Scatola trasmissione centrale
LOS252074	Front Gear Box/Bulkhead	Vorne Getriebekasten/Spritzwand	Boîte à engrenage avant/cloison	Carter trasmissione ant./Paratia
LOS252075	38T Ring and 12T Pinion Gear Front/Rear	38T Ring und 12T Zahnradgetriebe Vorne/Hinte	Anneau 38T et engrenage à pignons 12T avant/arrière	Corona 38T e pignone 12T ant./post.
LOS252076	Outdrive Set Front/Rear (2)	Antriebssatz Vorne/Hinte (2)	Ensemble d'arbre extérieur avant/arrière (2)	Kit trascinanti ant./post. (2)
LOS252078	Wheel Nut, Black (4)	Radmutter, Schwarz (4)	Écrou de roue, Noir (4)	Dadi ruote, nero (4)
LOS252080	Center Transmission Gear Set	Zentrales Übersetzungsgetriebe-Set	Ensemble boîte de transmission centrale	Kit ingranaggio trasmissione centrale
LOS252081	Stub Axle, Rear (2)	Achswellenstumpf, Hinte (2)	Demi-essieu, arrière (2)	Fuselli, posteriori (2)
LOS252082	Dogbone Rear Axle (2)	Dogbone, Hinterachse (2)	Essieu arrière Dogbone (2)	Cardano assale post. (2)
LOS252083	Motor Mount	Motorhalterung	Support moteur	Supporto motore
LOS252084	Center Drive Shaft, Front	Zentrale Antriebswelle, Vorne	Arbre de transmission central, avant	Albero di trasmissione centrale, ant.
LOS252087	Center Differential Outdrive Set (2)	Mitteldifferenzial Antriebssatz (2)	Ensemble d'arbre extérieur de différentiel central (2)	Kit trascinanti diff. centrale (2)
LOS252108	Front Differential Outdrive Shaft (2)	Vorne-Differenzial-Flexwelle (2)	Arbre d'entraînement extérieur différentiel avant (2)	Albero trascinatore diff. ant. (2)
LOS252109	Rotor, Caliper Set	Rotor, Bremssattelsatz	Ensemble de rotor, étrier	Kit freno a disco con pinza
LOS252110	Front Drive Shaft Slider Complete	Vorne-Antriebswelle Schieber, Komplet	Glisseur d'arbre d'entraînement avant complet	Cursore albero di trasmissione ant., completo
LOS252112	17mm Flanged Wheel Nut Black (4)	17mm Bordscheibenmutter, Schwarz (4)	Écrou de roue bridé, 17 mm, Noir (4)	Dado ruota, flangiato, 17 mm, nero (4)
LOS252128	Composite Rear Drive Shaft Slider Only	Hinteantriebswelle, Verbundmaterial, nur Schieber	Glisseur d'arbre d'entraînement arrière en composite uniquement	Solo cursore albero di trasmissione post., composito
LOS252129	17mm Wheel Hex, Black (4)	17mm Sechskantrad, Schwarz (4)	Écrou hexagonal de roue, 17 mm, Noir (4)	Esagono ruota, 17 mm, nero (4)
LOS252130	Rear Driveshaft Set	Hinte Antriebswelle-Set	Ensemble d'arbre de transmission arrière	Kit albero di trasmissione post.
LOS252131	Driveshaft Screwpin (10)	Antriebswellenschraube (10)	Vis pour l'arbre de transmission (10)	Vite dell'albero di trasmissione (10)
LOS254033	Shock Rebuild Kit (4)	Stoßdämpfer-Umbau-Kit (4)	Kit de reconstruction d'amortisseur (4)	Kit ricostruzione ammortizzatori (4)

Replacement Parts // Ersatzteile // Pièces de rechange // Pezzi di ricambio

Part #	English	Deutsch	Français	Italiano
LOS254034	Shock and Rod Ends, Spring Cups (12)	Stoßdämpfer- und Stangenenden, Federteller (12)	Extrémités d'amortisseurs et embouts de bielle, coupelles de ressorts (12)	Ammortizzatore e teste a snodo, coppe a molla (12)
LOS254035	Shock Pistons (8)	Stoßdämpferkolben (8)	Pistons amortisseurs (8)	Pistoni ammortizzatori (8)
LOS254038	Front Spindle Set (Left and Right)	Vorne-Spindelsatz (links und rechts)	Ensemble d'axe avant (gauche et droite)	Kit portafusello ant. (SX e DX)
LOS254039	Upper Arm/Shock Mount, Front	Oberer Arm/Stoßdämpferhalterung, Vorne	Bras supérieur/support d'amortisseur, avant	Attacco amm./braccio superiore, ant.
LOS254040	Shock Tower, Upper/Lower TrackRod Mount	Stoßdämpferbrücke, Obere/Untere Spurstangen-Montage	Tour d'amortisseur, support de barre d'accouplement supérieur/inférieur	Torre amm., supporto tirante sup./inf.
LOS254041	Shock Body and Collar Set, Front (2)	Stoßdämpfergehäuse und Hülsensatz, Vorne (2)	Ensemble de carrosserie d'amortisseur et bague, avant (2)	Kit corpo amm. e collare, ant. (2)
LOS254042	Shock Body and Collar Set, Rear (2)	Stoßdämpfergehäuse und Hülsensatz, Hinte (2)	Ensemble de carrosserie d'amortisseur et bague, arrière (2)	Kit corpo amm. e collare, post. (2)
LOS254043	Front/Rear Sway Bar Set	Vorne/Hintere Schwingen-Satz	Ensemble barre stabilisatrice avant/arrière	Kit barra antirollio ant./post.
LOS254044	Shock Shaft, Front (2)	Kolbenstange, Vorne (2)	Bras d'amortisseur, avant (2)	Aste amm., ant. (2)
LOS254045	Shock Shaft, Rear (2)	Kolbenstange, Hinte (2)	Bras d'amortisseur, arrière (2)	Aste amm., post. (2)
LOS254048	Front Hinge Pin and Brace Set	Vorne Scharnierstift und Klammersatz	Ensemble de support et d'axe de charnière avant	Kit rinforzo e perno articolazione ant.
LOS254051	Pivot Ball Set	Schwenkkugel-Set	Ensemble de rotules	Set articolazione a rotula
LOS254052	Hinge Pin Screw, Outer (4)	Scharnierbolzenschraube, Außen (4)	Vis de charnière, arrière, (4)	Viti perno articolazione, esterne (4)
LOS254066	Front, Lower Suspension Arms (L/R)	Unterer Querlenker, Vorne (L/R)	Bras de suspension inférieurs avant (L/R)	Bracci sospensioni inferiori, ant. (SX/DX)
LOS254067	Rear Trailing Arm	Längsträger Hinte	Bras oscillant arrière	Braccio post.
LOS254068	Rear Sway Bar Set (3)	Hintere Schwingen-Satz (3)	Ensemble barre stabilisatrice arrière (3)	Kit barra antirollio post. (3)
LOS254069	Shock Stand Off, Front (2)	Stoßdämpfer-Standoff, Vorne (2)	Dispositif d'espacement d'amortisseur, avant (2)	Distanziatore amm., ant. (2)
LOS254070	Upper 4-link Bar (2)	Obere viergliedrige Stange (2)	Barre à 4 bras supérieure (2)	Barra 4-link superiore (2)
LOS255009	Cap Head Screw, Steel, Black Oxide, M3 x 16mm (10)	Inbusschrauben, Stahl, Schwarzoxid, M3 x 16mm (10)	Vis d'assemblage, acier, brunie, M3 x 16 mm (10)	Viti a testa cilindrica, acciaio, nero ossido, M3 x 16 mm (10)
LOS255011	Button Head Screw, Steel, Black Oxide, M4 x 30mm (10)	Rundkopfschrauben, Stahl, Schwarzoxid, M4 x 30mm (10)	Vis à tête bombée, acier, brunie, M4 x 30 mm (10)	Viti a bottone, acciaio, nero ossido, M4 x 30 mm (10)
LOS255012	Button Head Screw, Steel, Black Oxide, M4 x 35mm (10)	Rundkopfschrauben, Stahl, Schwarzoxid, M4 x 35mm (10)	Vis à tête bombée, acier, brunie, M4 x 35 mm (10)	Viti a bottone, acciaio, nero ossido, M4 x 35 mm (10)
LOS255013	Button Head Screw, Steel, Black Oxide, M4 x 65mm (10)	Rundkopfschrauben, Stahl, Schwarzoxid, M4 x 65mm (10)	Vis à tête bombée, acier, brunie, M4 x 65 mm (10)	Viti a bottone, acciaio, nero ossido, M4 x 65 mm (10)
LOS255014	Button Head Screw, Steel, Black Oxide, M4 x 14mm (10)	Rundkopfschrauben, Stahl, Schwarzoxid, M4 x 14mm (10)	Vis à tête bombée, acier, brunie, M4 x 14 mm (10)	Viti a bottone, acciaio, nero ossido, M4 x 14 mm (10)
LOS255016	Flat Head Screw, Steel, Black Oxide, M4 x 10mm (10)	Flachkopfschrauben, Stahl, Schwarzoxid, M4 x 10mm (10)	Vis à tête plate, acier, brunie, M4 x 10 mm (10)	Viti a testa piana, acciaio, nero ossido, M4 x 10 mm (10)
LOS255018	Flat Head Screw, Steel, Black Oxide, M4 x 25mm (10)	Flachkopfschrauben, Stahl, Schwarzoxid, M4 x 25mm (10)	Vis à tête plate, acier, brunie, M4 x 25 mm (10)	Viti a testa piana, acciaio, nero ossido, M4 x 25 mm (10)
LOS255020	Flat Head Screw, Steel, Black Oxide, M4 x 18mm (10)	Flachkopfschrauben, Stahl, Schwarzoxid, M4 x 18mm (10)	Vis à tête plate, acier, brunie, M4 x 18 mm (10)	Viti a testa piana, acciaio, nero ossido, M4 x 18 mm (10)
LOS255021	Set Screw, Steel, Black Oxide, Flat Point, M4 x 6mm (10)	Stellschraube, Stahl, Schwarzoxid, Madenschraube, M4 x 6mm (10)	Vis de fixation, acier, brunie, bout plat, M4 x 6 mm (10)	Kit viti, acciaio, nero ossido, testa piana, M4 x 6 mm (10)
LOS255022	Set Screw, Steel, Black Oxide, Flat Point, M5 x 30mm (10)	Stellschraube, Stahl, Schwarzoxid, Madenschraube, M5 x 30mm (10)	Vis de fixation, acier, brunie, bout plat, M5 x 30 mm (10)	Kit viti, acciaio, nero ossido, testa piana, M5 x 30 mm (10)
LOS257006	Ball Bearing, 10 x 19 x 5mm (2)	Kugellager 10 x 19 x 5mm (2)	Roulement à billes 10 x 19 x 5 mm (2)	Cuscinetti a sfera, 10 x 19 x 5 mm (2)
LOS257007	Ball Bearing, 4 x 8 x 3mm (4)	Kugellager 4 x 8 x 3mm (4)	Roulement à billes 4 x 8 x 3 mm (4)	Cuscinetti a sfera, 4 x 8 x 3mm (4)
LOS43029	Beadlock Wheel and Ring Set (2)	Beadlock-Rad und Ringsatz (2)	Roue à verrou de talon et ensemble de joints (2)	Kit cerchie e ruote Beadlock (2)
LOS43030	BF Goodrich Mud Terrain KM3, Beadlock (2)	BF Goodrich Mud Terrain KM3, Beadlock (2)	BF Goodrich Terrain boueux KM3, verrou (2)	BF Goodrich KM3, fango, Beadlock (2)
LOSA6942	Sealed Ball Bearing, 8 x 16mm (4)	Abgedichtetes Kugellager, 8 x 16mm (4)	Roulement à billes hermétique, 8 x 16 mm (4)	Cuscinetti a sfera sigillati, 8 x 16 mm (4)
SPM2340	DX3 SMART DSMR 3 CH Transmitter	DX3 SMART DSMR Sender mit 3 Kanälen	Émetteur 3 canaux DSMR SMART DX3	Trasmittente DX3 SMART DSMR 3 canali
SPMS905	S905 Large Scale 40KG Waterproof Metal Gear Surface Servo, 15T	S905 großer 40KG Micro-Metallgetriebe-Oberflächenservo, wasserdicht, 15T	Servo de surface étanche, à engrenages, métallique, S905, à grande échelle, 40 kg, 15T	S905, servo per modelli di superficie, ingr. metallo, impermeabile, grande scala, 40 kg, 15T
SPMSR6100AT	SR6100AT DSMR 6-Channel AVC Telemetry Surface Receiver	SR6100AT DSMR AVC-Telemetrie-Oberflächenempfänger mit 6 Kanälen	Récepteur de surface de télémétrie AVC 6 canaux SR6100AT DSMR	Ricevitore di superficie SR6100AT DSMR 6 canali AVC con telemetria
SPMXSE1160	Firma 160Amp Brushless SMART ESC 8S	Firma 160A Bürstenloser Smart-Geschwindigkeitsregler 8S	Variateur ESC SMART sans balais 160 A Firma 8S	ESC Firma 160 A SMART Brushless 8S
SPMXSM2400	Firma 5687 750Kv Brushless Motor	Firma 5687 750Kv Bürstenloser Motor	Moteur sans balais 750 kV 5687 Firma	Motore Brushless Firma 5687 750 Kv
TLR235008	Flat Head Screw, M3 x 6mm (10)	Flachkopfschraube, M3 x 6mm (10)	Vis à tête plate, M3 x 6 mm (10)	Viti a testa piana, M3 x 6 mm (10)
TLR245008	Cap Head Screw, M2 x 10mm (10)	Inbusschraube M2 x 10mm (10)	Vis d'assemblage, M2 x 10 mm (10)	Viti a testa cilindrica, M2 x 10 mm (10)
TLR245009	Cap Head Screw, M4 x 16mm (10)	Inbusschraube, M4 x 16mm (10)	Vis d'assemblage creuse, M4 x 16 mm (10)	Viti a testa cilindrica, M4 x 16 mm (10)
TLR255004	Cap Head Screw, M2.5 x 8mm (10)	Inbusschraube, M2.5 x 8mm (10)	Vis d'assemblage creuse M2,5 x 8 mm (10)	Viti a testa cilindrica, M2,5 x 8 mm (10)
TLR255008	Button Head Screw, M4 x 16mm (10)	Rundkopfschraube, M4 x 16mm (10)	Vis à tête bombée, M4 x 16 mm (10)	Viti a bottone, M4 x 16 mm (10)
TLR255009	Button Head Screw, M4 x 20mm (10)	Rundkopfschraube, M4 x 20mm (10)	Vis à tête bombée, M4 x 20 mm (10)	Viti a bottone, M4 x 20 mm (10)
TLR255010	Button Head Screw, M4 x 25mm (10)	Rundkopfschraube, M4 x 25mm (10)	Vis à tête bombée, M4 x 25 mm (10)	Viti a bottone, M4 x 25 mm (10)
TLR255013	Flat Head Screw, M4 x 12mm (10)	Rundkopfschraube, M4 x 12mm (10)	Vis à tête plate, M4 x 12 mm (10)	Viti a testa piana, M4 x 12 mm (10)
TLR255014	Flat Head Screw, M4 x 20mm (10)	Rundkopfschraube, M4 x 20mm (10)	Vis à tête plate, M4 x 20 mm (10)	Viti a testa piana, M4 x 20 mm (10)
TLR255015	Setscrew, Cup Point, M4 x 5mm (10)	Stellschraube, Ringschneide, M4 x 5mm (10)	Vis de fixation, bout cuvette, M4 x 5 mm (10)	Grano, punta bombata, M4 x 5 mm (10)
TLR256005	Nylock Nut, M4 (10)	Nylock-Mutter, M4 (10)	Contre-écrou Nylock, M4 (10)	Dado Nylock, M4 (10)
TLR256006	Washer, M4 (10)	Unterlegscheibe, M4 (10)	Rondelle, M4 (10)	Rondelle, M4 (10)

Replacement Parts // Ersatzteile // Pièces de rechange // Pezzi di ricambio

Part #	English	Deutsch	Français	Italiano
TLR5901	Button Head Screw, M3 x 6mm (10)	Rundkopfschraube, M3 x 6mm (10)	Vis à tête bombée M3 x 6 mm (10)	Viti a bottone, M3 x 6 mm (10)
TLR5902	Button Head Screw, M3 x 8mm (10)	Rundkopfschraube, M3 x 8mm (10)	Vis à tête bombée M3 x 8 mm (10)	Viti a bottone, M3 x 8 mm (10)
TLR5903	Button Head Screw, M3 x 10mm (10)	Rundkopfschraube, M3 x 10mm (10)	Vis à tête bombée M3 x 10 mm (10)	Viti a bottone, M3 x 10 mm (10)
TLR5904	Button Head Screw, M3 x 12mm (10)	Rundkopfschraube, M3 x 12mm (10)	Vis à tête bombée M3 x 12 mm (10)	Viti a bottone, M3 x 12 mm (10)
TLR5906	Button Head Screw, M3 x 35mm (10)	Rundkopfschraube, M3 x 35mm (10)	Vis à tête bombée M3 x 35 mm (10)	Viti a bottone, M3 x 35 mm (10)
TLR5909	Button Head Screw, M3 x 16mm (10)	Rundkopfschraube, M3 x 16mm (10)	Vis à tête bombée M3 x 16 mm (10)	Viti a bottone, M3 x 16 mm (10)
TLR5911	Button Head Screw, M3 x 20mm (10)	Rundkopfschraube, M3 x 20mm (10)	Vis à tête bombée M3 x 20 mm (10)	Viti a bottone, M3 x 20 mm (10)
TLR5932	Cap Head Screw, M3 x 10mm (10)	Inbusschraube, M3 x 10mm (10)	Vis d'assemblage creuse, M3 x 10 mm (10)	Viti a testa cilindrica, M3 x 10 mm (10)
TLR5933	Cap Head Screw, M3 x 12mm (10)	Inbusschraube, M3 x 12mm (10)	Vis d'assemblage creuse, M3 x 12 mm (10)	Viti a testa cilindrica, M3 x 12 mm (10)
TLR5934	Cap Head Screw, M3 x 16mm (10)	Inbusschraube, M3 x 16mm (10)	Vis d'assemblage creuse, M3 x 16 mm (10)	Viti a testa cilindrica, M3 x 16 mm (10)
TLR5961	Flathead Screw, M3 x 8mm (10)	Flachkopfschraube, M3 x 8mm (10)	Vis à tête plate, M3 x 8 mm (10)	Viti a testa piana, M3 x 8 mm (10)
TLR5963	Flathead Screw, M3 x 12mm (10)	Flachkopfschraube, M3 x 12mm (10)	Vis à tête plate, M3 x 12 mm (10)	Viti a testa piana, M3 x 12 mm (10)
TLR5964	Flathead Screw, M3 x 16mm	Flachkopfschraube, M3 x 16mm	Vis à tête plate, M3 x 16 mm (10)	Viti a testa piana, M3 x 16 mm (10)
TLR6289	Set Screw, M3 x 5mm (10)	Stellschraube, M3 x 5mm (10)	Vis de fixation, M3 x 5 mm (10)	Kit viti, M3 x 5 mm (10)
TLR6291	Setscrew, M5 x 4mm, Flat Point (10)	Stellschraube, M5 x 4mm, Madenschraube (10)	Vis de fixation M5 x 4 mm, bout plat (10)	Grano, M5 x 4 mm, punta piana (10)
TLR6313	Locknut, M3 x .5 x 5.5mm (10)	Kontermutter, M3 x 0.5 x 5.5mm (10)	Contre-écrou M3 x 0,5 x 5,5 mm (10)	Controdadi, M3 x 0,5 x 5,5 mm (10)
TLR6352	Washer, M3 (10)	Unterlegscheibe, M3 (10)	Rondelle, M3 (10)	Rondelle, M3 (10)
VTR235035	Cap Head Screw, M3 x 30mm (10)	Inbusschraube, M3 x 30mm (10)	Vis d'assemblage creuse, M3 x 30 mm (10)	Viti a testa cilindrica, M3 x 30mm (10)

Recommended Parts // Empfohlene Teile // Pièces recommandées // Pezzi consigliate

Part #	English	Deutsch	Français	Italiano
DYN7177	17mm T-Handle Hex Wrench: LST2	17mm T-Sechskantschlüssel: LST2	Clé hexagonale, poignée en T, 17 mm : LST2	Chiave esagonale con impugnatura a T da 17 mm: LST2
DYNT1074	Deluxe 1/4" Large Scale Tool Set with Handle: 100/110mm	Deluxe 1/4" Großes Werkzeugset mit Griff: 100/110mm	Ensemble d'outils Deluxe à grande échelle de 1/4 po avec poignée : 100/110mm	Set di utensili Deluxe da 1/4", grande scala, con impugnatura: 100/110 mm
DYNT1260	Shock Shaft Pliers/Multi-Tool	Kolbenstangenzeuge/Multifunktionswerkzeug	Pincas de bras d'amortisseurs/Outil multifonctions	Pinze multiutensili per albero amm.
DYNT2010	Machined Nut Driver Set (4) Metric	Set gefräste Steckschlüssel (4) metrisch	Ensemble tourne-écrou usiné (4) Métrique	Kit di chiavi (4) metriche
SPMR5010	Spektrum DX5 Pro 5 Channel DSMR Transmitter Only	Spektrum DX5 Pro 5 Kanälen DSMR Sender	Émetteur 5 canaux Spektrum DX5 Pro DSMR	Trasmittente Spektrum DX5 Pro 5 canali DSMR
SPMR5115	Spektrum DX5C Smart 5-Channel DSMR Transmitter Only	Spektrum DX5C Smart 5-Kanälen DSMR Sender	Émetteur 5-canaux Spektrum DX5C Smart DSMR	Trasmittente Spektrum DX5C Smart 5 canali DSMR
SPMX50003S100H5	11.1V 5000mAh 3S 100C Smart Hardcase LiPo Battery: IC5	11.1V 5000mAh 3S 100C Smart Li-Po-Akku, Hartschale: IC5	Batterie LiPo Smart 11,1 V 5 000 mAh 3S 100C, boîtier rigide : IC5	Batteria 11,1 V 5000 mAh 3S 100C Smart Hardcase LiPo: IC5
SPMX50003S50H5	11.1V 5000mAh 3S 50C Smart Hardcase LiPo Battery: IC5	11.1V 5000mAh 3S 50C Smart Li-Po-Akku, Hartschale: IC5	Batterie LiPo Smart 11,1 V 5 000 mAh 3S 50C, boîtier rigide : IC5	Batteria 11,1 V 5000 mAh 3S 50C Smart Hardcase LiPo: IC5
SPMX50004S100H5	14.8V 5000mAh 4S 100C Smart Hardcase LiPo Battery: IC5	14.8V 5000mAh 4S 100C Smart Li-Po-Akku, Hartschale: IC5	Batterie LiPo Smart 14,8 V 5 000 mAh 4S 100C, boîtier rigide : IC5	Batteria 14,8V 5000 mAh 4S 100C Smart Hardcase LiPo: IC5
SPMX50004S50H5	14.8V 5000mAh 4S 50C Smart Hardcase LiPo Battery: IC5	14.8V 5000mAh 4S 50C Smart Li-Po-Akku, Hartschale: IC5	Batterie LiPo Smart 14,8V 5 000 mAh 4S 50C, boîtier rigide : IC5	Batteria 14,8V 5000 mAh 4S 50C Smart Hardcase LiPo: IC5
SPMXC1010	SMART S2100 AC Charger, 2X100W	Smart S2100 Wechselstrom-Ladegerät, 2x100 W	Chargeur CA Smart S2100, 2 x 100 W	Caricabatterie Smart S2100 CA, 2x100 W
SPMXCA507	Adapter: IC3 Battery/IC5 Device	Adapter: IC3-Akku/IC5-Gerät	Adaptateur : Batterie IC3/dispositif IC5	Adattatore: Da IC3 batteria a IC5 dispositivo
SPMXPS8	SMART Powerstage Bundle: 8S	Smart Leistungsteilpaket: 8S	Ensemble Smart Powerstage : 8S	Smart Powerstage Bundle: 8S
SPMXC1080	Spektrum Smart S1100 AC Charger, 1x100w	Spectrum Smart S1100 Wechselstrom-Ladegerät, 1x100 W	Chargeur CA Smart S1100 Spektrum, 1 x 100 W	Caricabatterie Spektrum Smart S1100 CA, 1x100 W

Optional Parts // Diverse Teile // Pièces optionnelles // Pezzi opzionali

Part #	English	Deutsch	Français	Italiano
DYN2930	4-Piece Metric Hex Wrench Set with Handle	4-teiliger metrischer Sechskantsatz mit Griff	Ensemble de 4 clés hexagonales métriques avec poignée	Set di chiavi esagonali metriche, 4 pezzi, con impugnatura
DYNT1071	1/4" Drive Large Scale Tool Set, Metric: 50mm	1/4-Zoll-Antrieb Werkzeugsatz, metrisch: 50mm	Ensemble d'outils à grande échelle à entraînement 1/4 po, métrique : 50 mm	Set di utensili da 1/4", grande scala, metrico: 50 mm
LOS252039	Pinion Gear 16T 8mm Shaft 1.5M	Zahnradgetriebe, 16T, 8mm Welle, 1.5M	Engrenage à pignons, 16T, arbre de 8 mm, 1,5 M	Pignone 16T, albero 8 mm, 1,5 m
LOS252040	Pinion Gear 17T 8mm Shaft 1.5M	Zahnradgetriebe, 17T, 8mm Welle, 1.5M	Engrenage à pignons, 17T, arbre de 8 mm, 1,5 M	Pignone 17T, albero 8 mm, 1,5 m
LOS252041	Pinion Gear 18T 8mm Shaft 1.5M	Zahnradgetriebe, 18T, 8mm Welle, 1.5M	Engrenage à pignons, 18T, arbre de 8 mm, 1,5 M	Pignone 18T, albero 8 mm, 1,5 m
LOS252043	Pinion Gear 20T 8mm Shaft 1.5M	Zahnradgetriebe, 20T, 8mm Welle, 1.5M	Engrenage à pignons, 20T, arbre de 8 mm, 1,5 M	Pignone 20T, albero 8 mm, 1,5 m
LOS252044	Pinion Gear 21T 8mm Shaft 1.5M	Zahnradgetriebe, 21T, 8mm Welle, 1.5M	Engrenage à pignons, 21T, arbre de 8 mm, 1,5 M	Pignone 21T, albero 8 mm, 1,5 m
LOS252045	Pinion Gear 22T 8mm Shaft 1.5M	Zahnradgetriebe, 22T, 8mm Welle, 1.5M	Engrenage à pignons, 22T, arbre de 8 mm, 1,5 M	Pignone 22T, albero 8 mm, 1,5 m
LOS252088	Pinion Gear 23T 8mm Shaft 1.5M	Zahnradgetriebe, 23T, 8mm Welle, 1.5M	Engrenage à pignons, 23T, arbre de 8 mm, 1,5 M	Pignone 23T, albero 8 mm, 1,5 m
LOS252089	Pinion Gear 24T 8mm Shaft 1.5M	Zahnradgetriebe, 24T, 8mm Welle, 1.5M	Engrenage à pignons, 24T, arbre de 8 mm, 1,5 M	Pignone 24T, albero 8 mm, 1,5 m
LOS351010	Aluminum Steering Servo Mount	Aluminium Lenkervohalterung	Support servo de direction en aluminium	Supporto servo sterzo alluminio
LOS354006	Aluminum Axle Housing Upper Track Rod Mount	Aluminium Achsgehäuse Obere Spurstange Halterung	Support de barre d'accouplement supérieur de carter d'essieu en aluminium	Carcassa assale in alluminio Supporto tiranti superiori
LOS354008	Aluminum Shock Tower Set Rear	Aluminium Stoßdämpferbrückensatz, Hinte	Ensemble de tour d'amortisseur en aluminium, arrière	Kit torre amm. post., alluminio
LOS354009	Aluminum Lower Trailing Arm Mount Set	Aluminium Unterer Achsträger Halterungssatz	Ensemble de support de bras oscillant inférieur en aluminium	Set di montaggio braccio post. inf. in alluminio
LOS354010	Aluminum Front Spindle Set	Aluminium Vorne-Spindelsatz	Ensemble d'axe avant en aluminium	Kit fuselli in alluminio, ant.
LOS354011	Aluminum Upper Track Rod Mount Set	Aluminium Obere Spurstange Halterungssatz	Ensemble de support de barre d'accouplement supérieur en aluminium	Set di montaggio tirante sup. in alluminio

Super
BAJAREY®
2.0



WWW.LOSI.COM

©2021 Horizon Hobby, LLC.

Losi, Baja Rey, DSM, DSM2, DSMR, AVC, Active Vehicle Control, EC5, Dynamite, Fuze, Prophet, Firma, DX3, and the Horizon Hobby logo are trademarks or registered trademarks of Horizon Hobby, LLC. The Spektrum trademark is used with permission of Bachmann Industries, Inc. Magnaflo, K&N, Kicker, Fox, Lucas Oil, and their respective logos are used under license by Horizon Hobby, LLC. All other trademarks, service marks and logos are property of their respective owners. US 9,320,977. US 10,528,060. US 9,930,567. US 10,419,970.

Other patents pending.

Updated 11/21

60345.1 | LOS05021