

71-2052-250
2/05

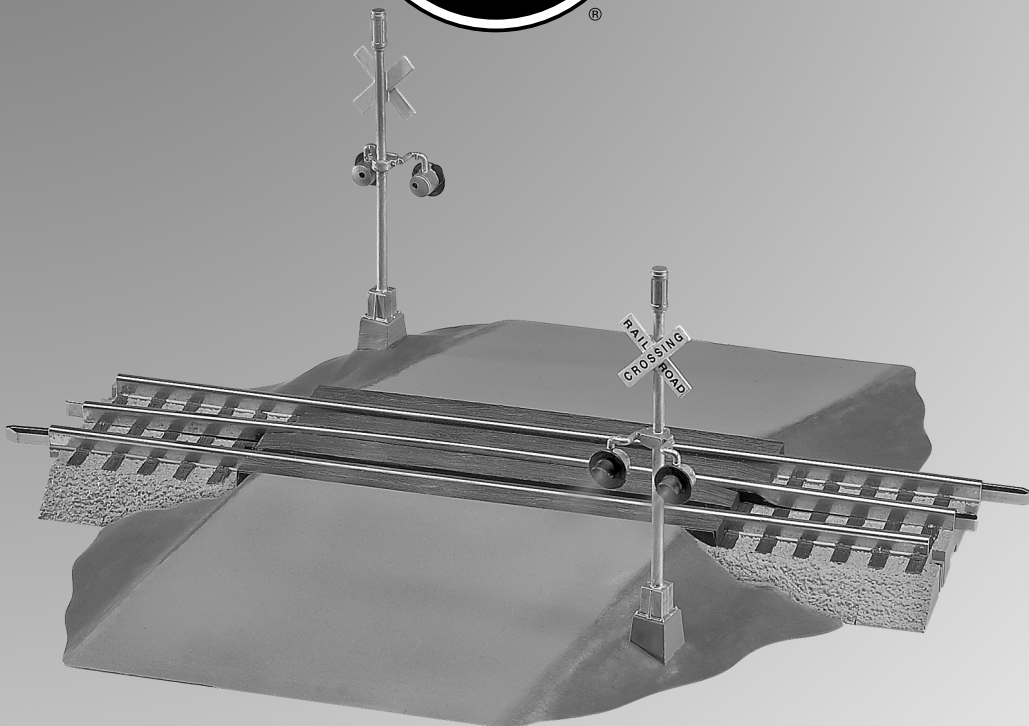

FastTrack[®]

Lionel

***Grade Crossing with Flashers
Owner's Manual***

Congratulations on your purchase of the Lionel FasTrack Grade Crossing with Flashers! This track section features two operating flashers and realistic bell sounds. When your train rolls across the broken outside rails on the insulated track sections (included), the lights begin to flash and the sounds are activated.

Inventory of parts

- **Grade crossing**
- **Two flasher signals**
- **Two signal bases**
- **Two Isolated Track sections**
- **Owner's Manual**
- **Service Center list**

Table of contents

Placing the Grade Crossing with Flashers on your layout	3
Joining the track sections	4
Installing the flashers	5
Operating the Grade Crossing and Flashers	6
Notes	7
Limited Warranty/Lionel Service	8

The following Lionel marks may be used throughout this instruction manual and are protected under law. All rights reserved.

Lionel®, *TrainMaster®*, *Odyssey®*, *RailSounds®*, *CrewTalk™*, *TowerCom™*, *DynaChuff™*, *StationSounds™*, *Pullmor®*, *ElectroCoupler™*, *Magne-Traction®*, *CAB-1® Remote Controller*, *PowerMaster®*, *Lionel ZW®*, *ZW®*, *PowerHouse®*, *TMCC®*, *Lionelville™*, *Lockon®*, *Wireless Tether™*, *LionMaster®*, *FatBoy™*, *American Flyer®*, *TrainSounds™*

The name FasTrack® is used with permission from Pitsco, Inc.

Placing the Grade Crossing with Flashers on your layout

Choose a location on your layout for the grade crossing. When you assemble the track sections, be sure that the “broken” rails on the Isolated Track sections (included) are on the same side (i.e., locate both “breaks” inside the track loop or outside the track loop). Be sure that the switch on the grade crossing is located on the same side as the breaks in the Isolated Track sections. Refer to Figure 1.

Note! The breaks must be located on the same side of the track.

If you would like your trains to activate the accessory earlier or to prolong the operation of the accessory, you may choose to purchase Insulated Track sections (6-12027). Be sure that the Insulated Track sections are next to the grade crossing and between the Isolated Track sections (included).

Note! Place only Insulated Track sections (available separately, 6-12027) and the grade crossing between the Isolated Track sections (included).

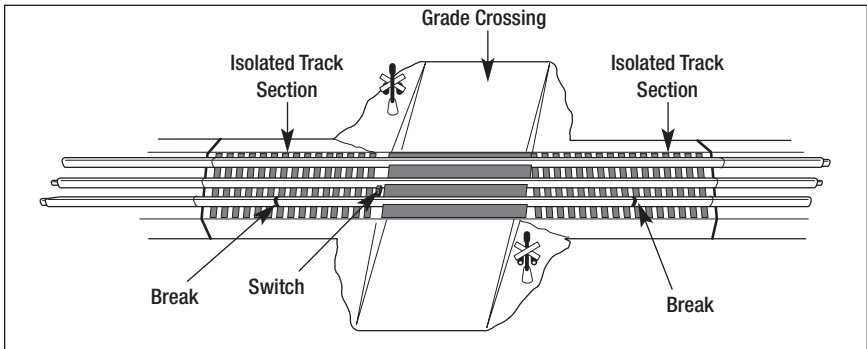

Figure 1. Grade Crossing location

Joining the track sections

FasTrack track sections join together easily. With interlocking roadbed sections and large rail tabs, the track fits together securely so you always get good electrical contact. Refer to Figure 2 to join the track sections.

1. Line up your two sections of track.
2. Insert the rail tabs into the openings at the ends of the corresponding rails.
3. Press the sections together until the interlocking roadbed snaps into place.

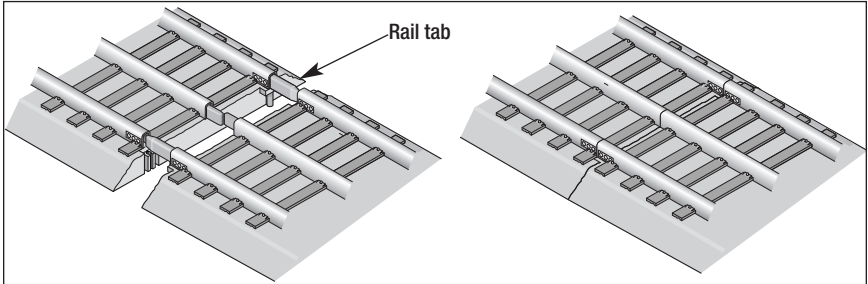

Figure 2. Joining the track sections

Installing the flashers

Your grade crossing includes two flashers. To install the flashers, snap the two bases into place and plug in the flashers. Refer to Figure 3.

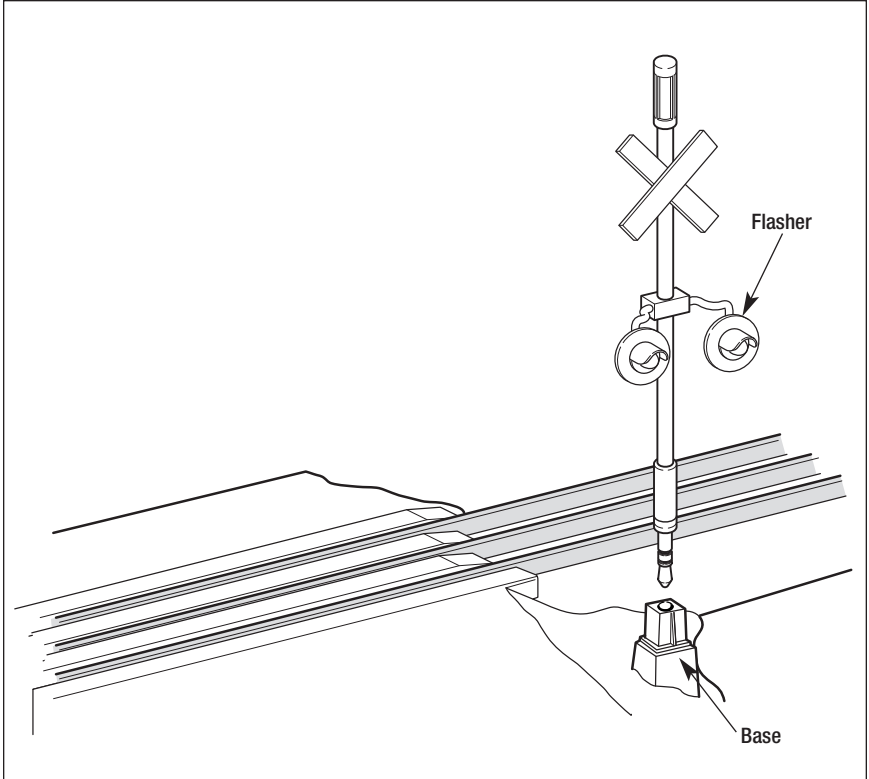

Figure 3. Flasher installation

Operating the Grade Crossing and Flashers

When the track is powered up and your train crosses over a “break” in the Isolated Track sections, the Grade Crossing will operate. Use the bell ON/OFF switch to control the operation of the bell sounds. The switch is illustrated in Figure 4. When the switch is in the OFF position, the bell sounds will not operate when the train triggers the flashers.

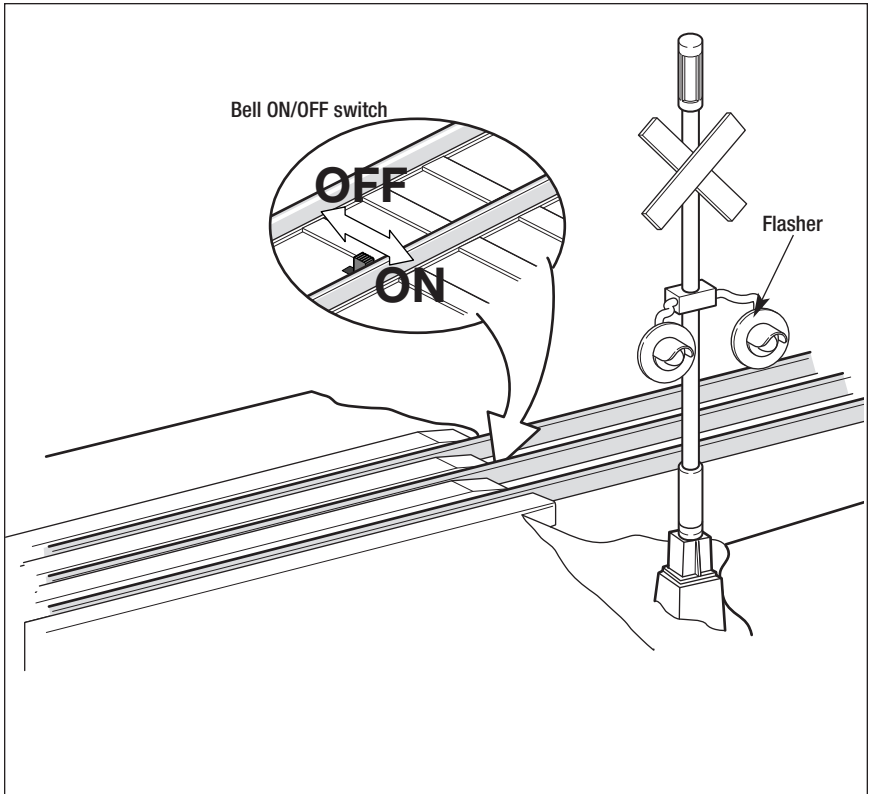

Figure 4. Bell ON/OFF switch

Limited Warranty/Lionel Service

This Lionel product, including all mechanical and electrical components, moving parts, motors and structural components, except for light bulbs, is warranted to the original consumer-purchaser, for **one year** against original defects in materials or workmanship when purchased through an authorized Lionel merchant.

This warranty does NOT cover normal wear and tear, light bulbs, defects appearing in the course of commercial use, or damage resulting from abuse or misuse of the product by the purchaser. Transfer of this product by the original consumer-purchaser to another person voids this warranty. Modification of this product voids this warranty.

Any warranted product which is defective in original materials or workmanship and is delivered by the original consumer-purchaser to Lionel L.L.C. or an authorized Lionel L.L.C. Service Center, together with proof of original purchase will, at the option of Lionel L.L.C., be repaired or replaced, without charge for parts or labor. In the event the defective product cannot be repaired, and a replacement is not available, a refund of the original purchase price will be granted. Any products on which warranty service is sought must be sent freight or postage prepaid, as transportation and shipping charges are not covered by the warranty.

In no event shall Lionel L.L.C. be liable for incidental or consequential damages.

Some states do not allow the exclusion or limitation of incidental or consequential damages, so the above exclusion may not apply to you.

This limited warranty gives you specific legal rights, and you may have other rights which vary from state to state.

Instructions for Obtaining Service

If service for this Lionel L.L.C. product is required, bring the item, along with your dated sales receipt and completed warranty information to the nearest Authorized Lionel Service Center. Your nearest Lionel Service Center can be found by calling 1-800-4-Lionel, or by accessing our Website at www.lionel.com.

If you prefer to send your product back to Lionel L.L.C. for repair in Michigan, you must first call 586-949-4100 or FAX 586-949-5429, or write to Customer Service, P.O. Box 748, New Baltimore, MI 48047-0748, stating what the item is, when it was purchased and what seems to be the problem. You will be sent a return authorization letter and label to ensure your merchandise will be properly handled upon receipt.

Once you have received your return authorization and label, make sure that the item is packed to prevent damage during shipping and handling. We suggest that you use the product's original packaging. This shipment must be prepaid and we recommend that it be insured.

Please make sure you have followed all of the above instructions carefully before returning any merchandise for service. You may choose to have your product repaired by one of our Authorized Lionel Service Centers after its warranty has expired. A reasonable service fee will be charged.

Warranty Information

Please complete the information below and keep it, along with your dated sales receipt. You must present this and your dated sales receipt when requesting warranty service.

Name _____

Address _____

Place of Purchase _____

Date of Purchase _____

Product Number _____

Product Description _____



©2005 LIONEL L.L.C., CHESTERFIELD, MI 48051-2493
UNITED STATES OF AMERICA
PRINTED IN CHINA