

ZENOAH[®]

ENGINE INSTRUCTION MANUAL

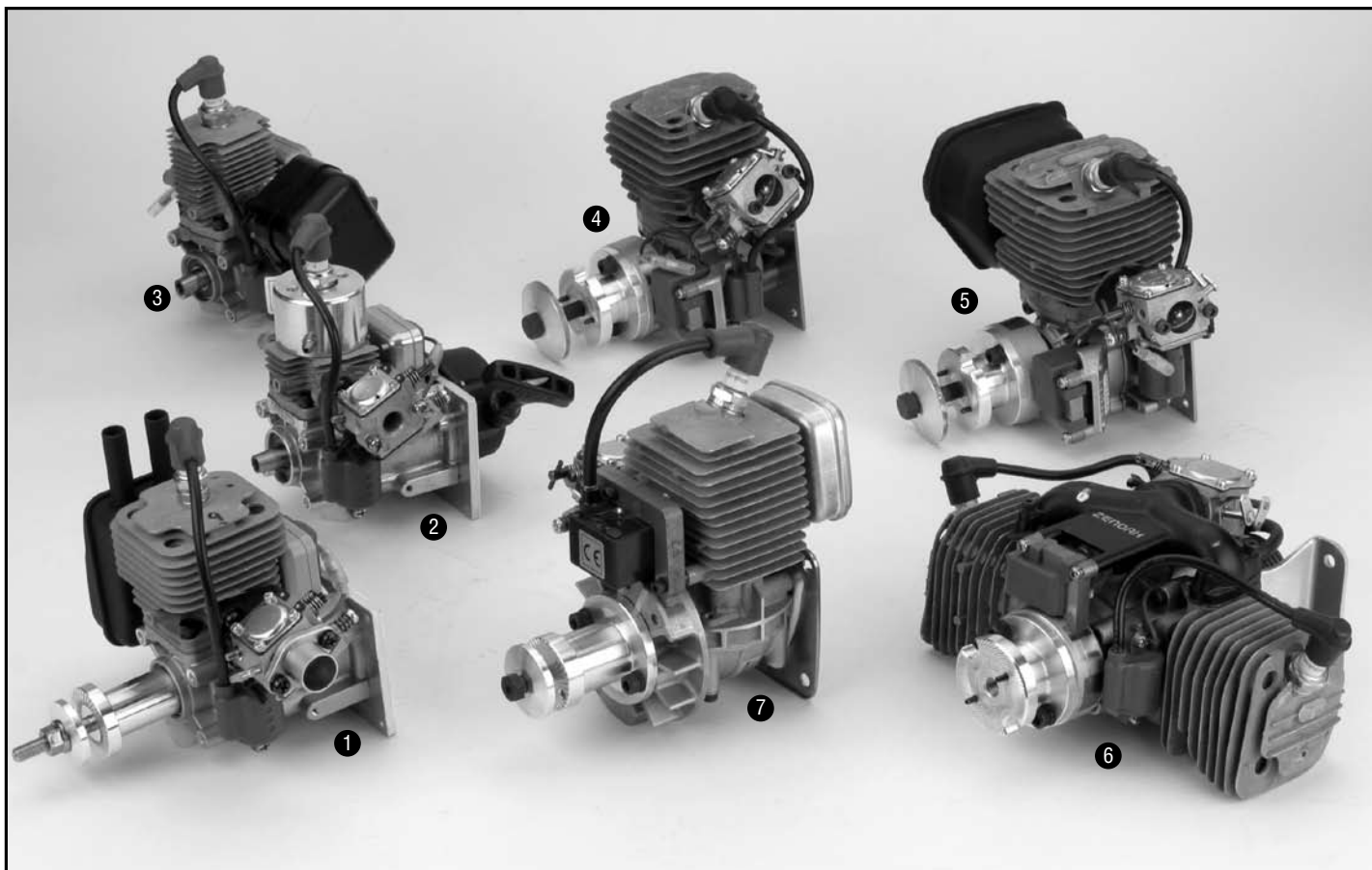

G26 Air ①

G26/G23 I Marine ②

G26/G23 I Heli ③

G38 ④

G62 ⑤

GT80 Twin ⑥

G45 ⑦

Table of Contents

- Introduction 3
- Safety Instructions 3
- Support Equipment..... 4
- Mounting the Engine..... 5
- Operation 5
 - Break In 5
 - Starting the Engine, Aircraft..... 5
 - Starting the Engine, Heli & Boat 6
 - Stopping the Engine 6
 - Carburetor Adjustment 6
- Engine Care and Maintenance..... 7
 - Recommendations..... 7
 - Servicing the Engine 7
 - Disassembly 7
 - Assembly..... 8
 - Charts 9
- Troubleshooting Guide for Gasoline Engines 11
- Propeller Chart 12
- Engine Specifications 13
- Exploded Illustration..... 14
 - G26/G231 14
 - G38 16
 - G45 17
 - G62 18
 - GT80 19
- Warranty Information 20
 - Warranty Repairs..... 20
 - Non-Warranty Repairs 20
 - Registration Form 21

Very Important

FAILURE TO READ AND FOLLOW THESE INSTRUCTIONS BEFORE YOU PROCEED MAY RESULT IN ENGINE DAMAGE AND THE VOIDING OF YOUR WARRANTY!

Introduction

Congratulations on purchasing a Zenoah® engine. Cared for properly, these high-quality, finely crafted engines will offer many years of reliability.

This instruction manual has been developed to ensure optimum performance from the Zenoah engine you have purchased. It's important that the instructions are read thoroughly prior to mounting and running the engine.

Safety Instructions

This manual describes the engine's features and functions. For specific information on mounting, see the instruction manual included with the model airplane, helicopter or boat in which you intend to install the engine.

This model engine will give you considerable pleasure, satisfaction and performance if you strictly follow these safety instructions and take heed of the warnings as to the engine's safe and proper use. This engine has more than enough power to cause harm if misused or if the safety precautions are not observed.

Always

1. Use genuine parts for replacement.
2. Check the propeller, rotor (helicopter) or screw propeller (boat) prior to each time the engine is used. If nicked, scratched, cracked or damaged in any way, replace it with a new one.
3. Use the correct size and pitch of propeller for your engine; refer to the propeller chart in this manual.
4. It is extremely important to balance the propeller prior to installation of the engine. Failure to do so may cause damage to the Zenoah engine and/or the airframe. Securely tighten the propeller nut against the washer and propeller.
5. Inspect the tightness of the propeller nut prior to each flight.
6. Keep your face and body away from the path of the propeller blades when starting or running your engine.
7. Use a thickly padded glove when hand starting the engine.

8. Make all carburetor adjustments from behind the propeller.

9. To stop the engine, the black lead wire from the coil should be grounded to the engine body, or use the throttle linkage to shut off the air by closing the throttle valve completely.

DO NOT USE HANDS, FINGERS OR ANY OTHER PART OF THE BODY TO STOP THE PROPELLER. DO NOT THROW ANY OBJECT INTO A PROPELLER TO STOP IT!

10. Ensure that all spectators, especially children, are at least 20 feet away when you start running the engine.

11. Make sure your fuel is kept in a safe place well away from sparks, heat or anything that could ignite the fuel.

Recommendations

1. Use safety glasses or goggles when starting and running your engine.
2. Do not run the engine in the vicinity of loose gravel or sand. The propeller may throw such materials into your eyes. The engine could also ingest these harmful materials.
3. Avoid loose clothing when operating your model engine, as it could become entangled in the propeller, creating the possibility of bodily harm. All loose objects (screwdrivers, pencils, nickel cadmium glow drivers, etc.) should be removed from your pockets so that they do not fall into the propeller.

Safety Instructions (continued)

Caution

1. Model engines get very hot while running. Do not attempt to handle them until they have cooled.
2. Always run your model engines in a well-ventilated area. Similar to automotive engines, model engines produce harmful carbon monoxide fumes.
3. Never modify the flywheel.
4. Check the flywheel. If it's damaged, replace it with a new one.
5. When mixing the fuel or operating the engine, do so in a well-ventilated area.
6. Remember that model engines produce a substantial amount of power, more than enough to seriously injure people and/or do considerable damage to property. Always use common sense, skill and constant observance of safety precautions.

Disassembly

The Zenoah® engine can be disassembled or reassembled without any specific difficulties. Refer to the Engine Maintenance Section for specific instructions on these procedures. If you need service to your Zenoah engine, please send it to the authorized service center at the following address:

Horizon Hobby, Inc.
Attention: Zenoah Service
4105 Fieldstone Road
Champaign, IL 61822
Phone: (217) 355-9511

Engine Parts Identification

It's important to be able to identify the parts of your Zenoah engines. Inside this manual you will find an exploded view of Zenoah engines, as well as a chart including part numbers and descriptions. This will assist you in easily and rapidly identifying the respective parts of your Zenoah engine.

Support Equipment

The following items are not included with your Zenoah engine but are necessary for operation.

Fuel—Mix gasoline and 2-stroke gas compatible oil at a mixing ratio of 25–40:1.

Note: Be sure to use a gasoline-resistant fuel tubing (do not use any silicone rubber tube). Never use any alcohol fuel or alcohol-added fuel as this will damage the rubber part of the carburetor.

Propeller—Refer to the Propeller Selection Chart located on Page 8 to determine the best initial propeller for your particular application.

Manual or Electric Starter—For manual starts, a chicken stick is highly recommended. **Never** use your fingers to start any model engine as you could be injured. If you must hand-start a gasoline engine, be sure to protect your hand with a heavily padded glove. There are a variety of heavy-duty electric starters on the market that can be used.



Evolution Oil
EVOX1001Q

Mounting the Engine

Make sure the engine is mounted on the aircraft using aircraft grade plywood that's at least 6mm in thickness for the G26 engine, and 10mm in thickness for the G38 through GT80 twin, or a mount of equivalent strength. Make sure it's firmly mounted with 4 bolts.

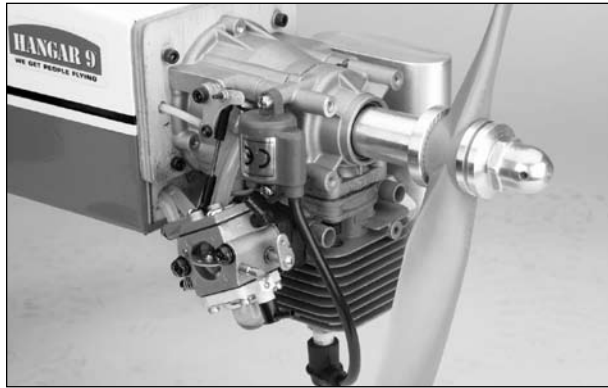

1. Be sure to set flat washers or a metal plate on the reverse side of the mount to prevent the bolts from sinking into the mount. Periodically check the engine mount for loose bolts.

2. Since the engine is equipped with a floatless carburetor with a diaphragm pump, the direction of the cylinder and position of the fuel tank can be freely selected.

3. If the engine is mounted on a shock (rubber) mount placed between the engine and the firewall for anti-vibration, check the hardness of the rubber, making sure it's not too soft, in order to avoid excessive vibration during engine operating rpms. Note carefully if the engine is vibrating at idle, as excessive vibration can result in erratic engine operation due to overflow at the carburetor.

4. It is suggested that the bolts for the muffler be coated with threadlock when mounting the muffler to the engine.

Operation

Break In

No specific break in is required. The engine is gradually broken in as it is used, and the output power increases gradually as the engine breaks in.

Starting the Engine—Aircraft

Before attempting to start the engine, be sure to read through all the steps for starting the engine as outlined below:

Zenoah engines are equipped with the ultra compact C.D.I. type flywheel magneto ignition system and should be started according to the following procedure:

Note: The magneto system is timed in such a way that when the compression stroke starts (refer to Figure 1-A) sparks are never produced on the spark plug, no matter how fast the propeller is flipped. The correct starting procedure is to quickly flip the propeller when the edge of the magnet on the rotor is approaching the coil (Figure 1-B). This means that the propeller should be quickly flipped at about 90 degrees in crank angle before the compression stroke is about to start.

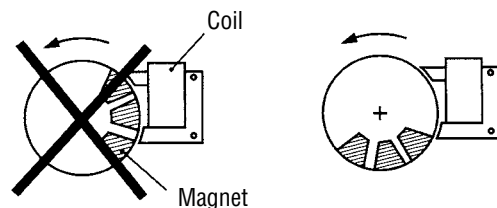

Fig 1-A

Fig 1-B

1. Make sure the spark (glow) plug(s) are installed and tightened. Check the condition of the plug cap for cracks or breaks.
2. Be sure the propeller is properly secured.
3. Make sure the fuel tank line(s) are properly connected. The main line should be connected to the carburetor spray bar.
4. Be certain the mufflers are installed properly.
5. Fill the fuel tank.
6. Choke the engine and turn the propeller through a few times until the fuel appears at the carburetor.
7. Set the throttle valve at the idle position or at the position slightly open from idle.

Operation (continued)

8. Quickly flip the propeller in a counterclockwise direction. (See note on previous page)
9. The engine should start after a few flips of the propeller.
10. Be sure to open the choke when the initial firing of the engine is heard.
11. When the choke is opened, be sure to close the throttle valve to a position near the idle position before the next flipping of the propeller is attempted.
CAUTION: If the engine is started when the throttle is wide open, a great thrusting force will be generated, which can be very dangerous.
12. If you do not use a chicken stick to start the engine, be sure to wear a thick glove when flipping the propeller and use all fingers, except the thumb, for the flipping operation.
13. Do not over-rev the engine. These engines are designed to develop maximum output with the standard muffler and the recommended propeller size. Please refer to the propeller chart on page 10 to confirm the proper propeller for the applicable Zenoah® engine.

Starting the Engine—Helicopter and Boat

1. Fill the tank with fuel.
2. Push the priming bulb located on the carburetor until fuel appears in the priming bulb (for helicopter).
3. Choke the engine and open the throttle valve approximately 1/3–1/2 of the full open position.
4. Quickly pull the starter cord until the initial firing of the engine is heard.
5. When the initial firing is heard, open the choke, set the throttle valve at the idle position or at the position slightly open from the idle position and quickly pull the starter cord a few more times until the engine starts.
6. For helicopter operation, you should adjust the rotor-pitch to obtain a 9,000 to 10,000 rpm of the engine at full throttle operation.

Stopping the Engine

The ability to shut down the engine in an emergency is extremely important. For stopping the engine, the black lead wire from the coil should be grounded to the engine body, or the throttle valve should be closed completely. Installation of a “stop” or “kill” switch is recommended.

We recommend the Zenoah ZEN20000 Kill Switch. Refer to the example shown in the following diagram.

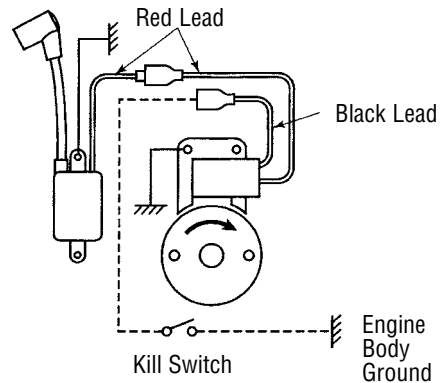

Carburetor Adjustment

The carburetor is provided with three adjustment screws, which are factory set to the best (approximate) positions. They may need minor adjustment, depending upon the temperature, humidity, atmospheric pressure (altitude), etc., of the area where the engine is being used.

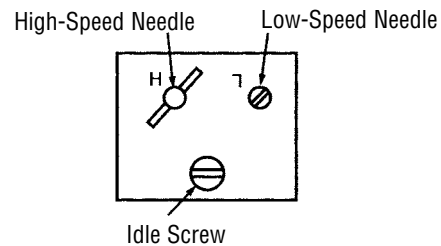

1. Start the engine without making any adjustments.
2. Make adjustments only when the engine shows signs of inefficient operation.
3. Standard settings of each needle is as follows:
 - a. Low-Speed Needle: $1\frac{1}{8}$ plus/minus $\frac{1}{4}$
 - b. High-Speed Needle: $1\frac{3}{8}$ plus/minus $\frac{1}{4}$

Idle Screw: Turning this screw clockwise increases the idling rpm. Turning it counterclockwise decreases the idling rpm.

Low-Speed Needle: This is the fuel adjust screw (not the air screw). Turning this needle clockwise makes the gas mixture leaner, and turning it counterclockwise makes it richer.

Operation (continued)

High-Speed Needle: Turning this needle clockwise makes the gas mixture leaner, and turning it counterclockwise makes it richer. Set this needle at a position which is 1/4 open from the maximum rpm position while the aircraft is on the ground.

Note: Do not tighten the high and low speed needles too tightly.

When the engine has just started and is not warm enough, there may be insufficient acceleration and the engine may die. Be sure to allow the engine to warm up at idle for a few minutes before conducting normal operation.

Engine Care and Maintenance

Recommendations

To extend the life of your Zenoah® engine, the following is recommended:

1. Use an Evolution quality 2-stroke oil mixed at 32 to 1.
2. Use the recommended spark plugs.
3. Use the proper propeller size and balance the propeller prior to use.
4. Always adjust the engine to a slightly rich setting.
5. For long-term storage, make sure there is no fuel left in the tank or the engine. Remove the spark plug(s) and apply several drops of high-quality oil (e.g., Marvel Air Tool Oil) to the top of the engine and into the spark plug hole. Rotate the crankshaft several times. Store the engine in the box it came in or on the airplane with the nose down in order to keep oil in the bearings.

Servicing the Engine

Required Tools

- Regular screwdriver
- Phillips screwdriver
- Hexagonal wrench (4mm⁵/₃₂"
- Open wrench (19mm³/₄"
- Plastic hammer
- Thickness gauge
- Tapered round rod
- Liquid gasket (Permatex or equivalent)
- Threadlock (Blue Threadlock Z-42 or equivalent)
- Lithium grease

- Engine oil
- Washing gasoline
- Brush
- Scraper
- Cloth

The engine can be disassembled or reassembled without any specific difficulties, but note the following:

For disassembling, the special tools shown in the parts list are required (stopper, puller assembly), in addition to general tools. Be sure to use a new gasket when the crankcase and cylinder have been disassembled.

Note: Because the crankshaft is of the assembly type, do not disassemble, hit or twist its end.

Disassembly

1. Dismount the engine from the model.
2. Remove the carburetor and insulator carefully without damaging the gasket.
3. Remove the muffler.
4. Remove the spark plug and ignition module.
5. Remove the propeller hub.
6. Remove the rotor (flywheel). If it cannot be detached, use a plastic hammer and tap the part lightly.
 - a. Screw the stopper in place of the spark plug, then turn the rotor counterclockwise until the piston touches the stopper. Take care, as it can cause damage to the piston or connecting rod if the stopper is not screwed into the bottom.
 - b. Loosen and remove the rotor securing nut.

Engine Care and Maintenance (continued)

- c. Remove the rotor by using the puller. Do not hit the crankshaft with the plastic hammer, as this can increase the runout of the shaft.
7. Remove the mounting plate.
8. Remove the four bolts from the crankcase.
9. Tap around the case fitting side gently with the plastic hammer and slowly separate the crankcase from the cylinder block.
10. Pull out the crankshaft with the piston, bearings, and other parts attached.
11. Remove the Woodruff key from the crankshaft.
12. Remove the oil seal, snap ring and bearings.
13. Remove the circlip and pull out the piston pin.
14. Remove the thrust washers and needle bearing from the smaller end of the connecting rod (G38).
15. Remove the piston ring.
16. Wash each part. Check for abrasion and damage, and replace any part that is defective.
7. Wipe the contact surfaces of the cylinder block and crankcase, and apply liquid gasket (Permatex or equivalent).
8. Put the piston in the cylinder, with the piston's arrow facing in the exhaust port direction. Set the crankshaft to the cylinder block. Then, fit the oil seal to the cylinder block. The snap ring joint should be set vertically to the cylinder.
9. Fit the crankcase to the cylinder block and tighten the bolts.
10. Check that the crankshaft can be smoothly turned by hand.
11. Put back the Woodruff key.
12. Replace the rotor (flywheel), fitting it to the Woodruff key. Tighten the hub nut after having applied threadlock (Blue Threadlock Z-42 or equivalent) to the threads.
13. Apply threadlock (Blue Threadlock Z-42) to the muffler bolts and mount the muffler.
14. Apply threadlock (Blue Threadlock Z-42) to the ignition module setscrews and fix the coil temporarily.
15. Set the rotor (flywheel) so that the magnet is located on the opposite side of the module (G38). Place a thickness gauge between the core of the module and rotor (flywheel) and adjust the clearance to $0.25 \text{ } ^\wedge \text{ } 0.35 \text{ mm}$ ($0.01 \text{ } ^\wedge \text{ } 0.014 \text{ in}$). Then tighten the setscrews after having applied threadlock (Blue Threadlock Z-42) to them.

Assembly (G38)

1. Apply engine oil (SAE #30) to the inside of the cylinder and to the needle bearings on the larger end of the connecting rod.
2. Fit the piston ring to the piston.
3. Mount the needle bearing and thrust washer (with its oil slot facing inside) to the smaller end of the connecting rod and apply engine oil (SAE #30).
4. With the arrow on the top of the piston facing the straight side (opposite side to the propeller) of the crankshaft, fit the piston to the top of the connecting rod and insert the piston pin with its blank end to the exhaust port side.
5. Fit the circlip.
6. Fit the bearings, snap ring and oil seal to the crankshaft. (Apply lithium grease to the lip area of the oil seal and fit it, paying attention to its direction.)
16. Using a new gasket, fix the insulator with screws to which threadlock (Blue Threadlock Z-42) has been applied.
17. Using a new gasket, mount the carburetor with screws, paying attention to its mounting direction.
18. Tighten the mounting plate, using screws with threadlock (Blue Threadlock Z-42) applied.
19. Install the spark plug.

Note: Disassembly and assembly steps were written using a G38 engine as an example, but they apply to all engines.

Engine Care and Maintenance (continued)

Maintenance Chart

Items	Action	Before Use	Every 25 hours	Every 100 hours	Note
Leakage, Damage/Crack	Check	✓	✓	✓	
Losing Speed	Check/Adjust	✓	✓	✓	
Air-cleaner (PUH)	Check/Cleaning	✓	✓	✓	Replace if necessary
Spark Plug (gap)	Check/Adjust		✓	✓	↑
Cylinder (barrel)	Check/Cleaning		✓	✓	↑
Piston, Ring	Check/Cleaning		✓	✓	↑
Muffler & Bolt	Check/Cleaning	✓	✓	✓	↑
Bearings	Check/Cleaning		✓	✓	↑
Crankshaft	Check/Alignment		✓	✓	↑
Rotor	Check		✓	✓	↑
Propeller Hub (PU)	Check/Alignment		✓	✓	↑
Water Jacket (PUM)	Check/Leakage	✓	✓	✓	↑

Specifications & Technical Data

Items	Unit	G260PU	G260PUM	G260PUH	G231PUM	G231PUH
Type	—	Air Cooled	Water Cooled	Air Cooled	Water Cooled	Air Cooled
Bore x Stroke	mm	34 x 28	←	←	32 x 28	←
Displacement	cm ³	25.4	←	←	22.5	←
Effective Compression Ratio	—	8.4	←	←	←	←
Carburetor	Type (Walbro)	WT-645	WT-644	WT-677	WT-644	WT-677
	Venturi (mm)	12.7	←	←	←	←
Air Cleaner		—	—	Dry Type	—	Dry Type
Starting	—	Hand Flipping or Electric Motor	Recoil Starter	←	←	←
Ignition	Type	CDI	←	←	←	←
	BTDC/rpm	28/7000	30/7000	←	←	←
Spark Plug	STD	RZ7C	←	←	←	←
	Option	—	CMR8H/7H	—	CMR6H/7H	—
Idle Speed	rpm	1800 APC 18 x 8	3500	3000	3500	3000
Max. Power	rpm	1.62/12000	2.16/12000	1.71/13000	2.09/12000	1.58/13000
Min. Torque	rpm	1.48/9000	1.94/9500	1.42/9500	1.79/10000	1.34/9000
Fuel Consumption	cc	790	710	760	720	700
Weight	kg	1.69 (* 1.52)	1.54	1.77 (*1.57)	1.55	1.78 (*1.58)

Engine Care and Maintenance (continued)

Maintenance Specifications

	Items	Standard	Limit	Standard	Limit	Measuring Device	Remarks
Cylinder	Bore (mm)	ø34	Plating damaged	ø32	Plating damaged	Eye Checking	
Piston	Diameter (mm)	ø33.97	ø33.87	ø31.97	ø31.87	Micro Meter	At the skirt end and the right angle to the piston pin
	Piston Ring Groove Width (mm)	1.01	1.11	1.01	1.11	Thickness Gauge	
	Piston Ring Hole (mm)	ø8.01	ø8.05	ø8.01	ø8.05	Cylinder Gauge	
	Clearance Between Piston and Cylinder (mm)	0.03–0.05	0.15	0.03–0.05	0.15	Micro Meter Cylinder Gauge	
	Clearance Between Groove and Piston Ring (mm)	0.02–0.04	0.1	0.02–0.04	0.1	Thickness Gauge	
Piston Ring	End Gap (mm)	0.05–0.25	0.5	0.05–0.25	0.5	Thickness Gauge	When inserted in a new cylinder
	Width (mm)	0.98	0.93	0.98	0.93	Micro Meter	
Piston Pin Diameter (mm)		ø8	ø7.98	ø8	ø7.98	Micro Meter	
Connecting Rod, Small End (mm)		ø11	ø11.05	ø11	ø11.05	Cylinder Gauge	
Crankshaft Dia. at Main Bearing (mm)		ø12	ø11.98	ø12	ø11.98	Micro Meter	
	Eccentricity (mm)	—	0.07	—	0.07	Dial Gauge	
	Axial Play (mm)	—	0.5	—	0.5	Thickness Gauge	
	Main Bearing	—	Gritty or Has Flat Spot	—	Gritty or Has Flat Spot	—	

Troubleshooting Guide for Gasoline Engines

Generally speaking, there are very few things that will keep today's modern engines from starting. Use good quality "fresh" fuel and make sure that good plugs are

installed. Should the engine fail to start after these items are verified, refer to the charts on the following page.

a) The engine does not start.

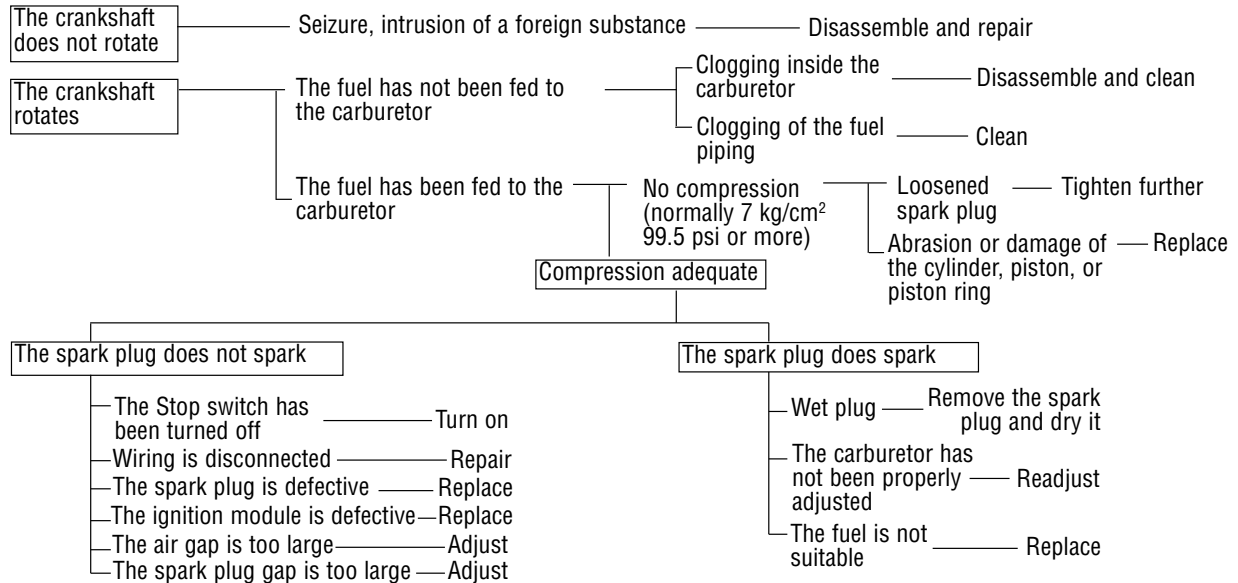

b) The engine stops by itself

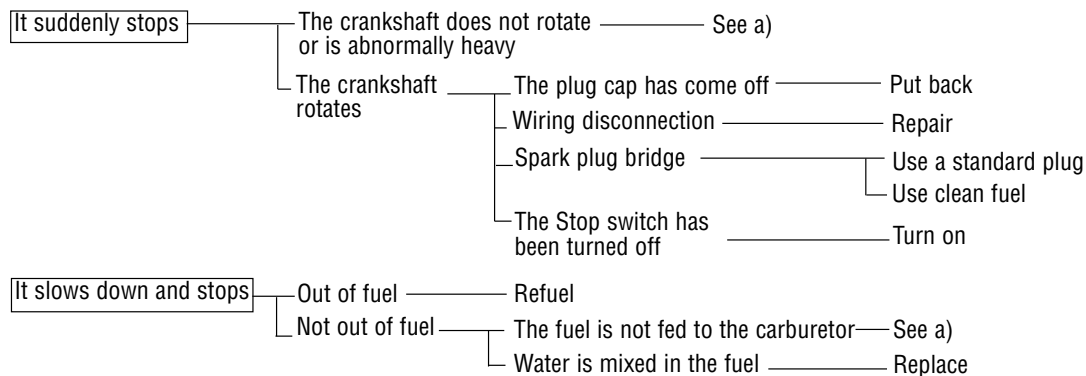

c) Lower power output

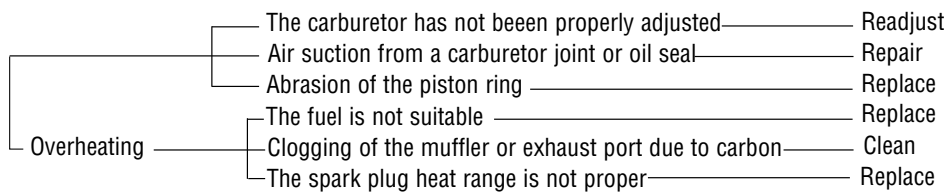

d) The engine does not stop

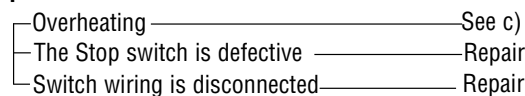

Troubleshooting Guide for Gasoline Engines

(continued)

In the event that none of the above procedures result in the engine running properly, contact our service department for suggestions at:

Horizon Hobby, Inc.
4105 Fieldstone Road
Champaign, IL 61822
Phone: 217-355-9511 (M-F 8:00-5:00 CST)

Propeller Chart

This chart enables you to select the best propeller for initial setup of your Zenoah engine.

Remember, it's imperative to balance each propeller prior to installation onto your Zenoah engine. Failure to do so may cause unwanted vibration in your aircraft.

Note: All recommendations are based on engines using APC brand props.

ENGINE	PROPELLER
G26A	16x8 @ 8,700
G231 Heli G26 Heli	Adjust pitch of rotor to obtain 9,000-10,000 rpm of the engine at full throttle
G26 Marine G231 Marine	Diameter = 65-75mm Pitch ratio 1.9-1.4mm
G38 Gas	18x10 @ 7,300
G45 Gas	20x10 @ 7,200
G62 Gas	22x10 @ 7,200
GT80 Gas	22x12 @ 7,200 24x10 @ 7,200

Engine Specifications

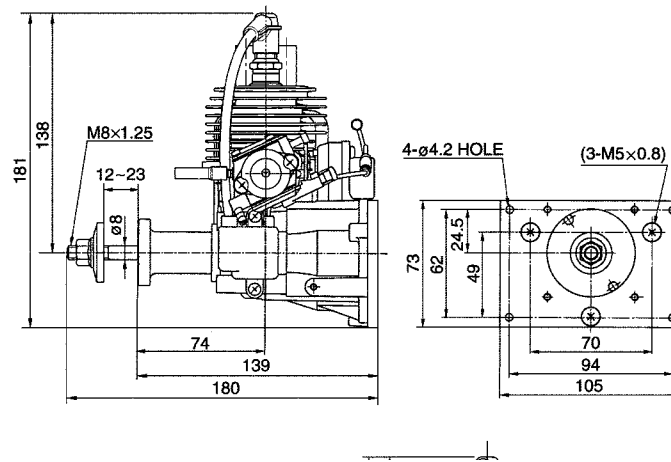

OUTSIDE DIMENSIONS (MM)

Items	Length	Width	Height	Operating RPM	Optional Mufflers
G26A	139mm	105mm	181mm	2,000–10,000	BIS07123
G26M	139mm	105mm	181mm	2,000–10,000	—
G26H	139mm	105mm	181mm	2,000–10,000	—
G231 HELI	142mm	105mm	181mm	3,000–11,000	—
G231 MARINE	142mm	105mm	181mm	3,500–15,000	—
G38	170mm	130mm	215mm	2,000–9,000	BIS07138
G45	152mm	130mm	185mm	2,000–10,000	BIS07145
G62	162.5mm	140mm	185mm	2,000–10,000	BIS07163
GT80	191.5mm	257mm	190mm	1,800–10,000	BIS07445/6

SPECIFICATIONS

	Displacement (cu in)	Bore (in)	Stroke (in)	Weight (oz)	K (ISO)	HP (H/M)	Carb (Walbro)
G26A/M/H	1.55	1.41	1.1	54/57	M8x1.25/6x1	2.4	WT645/WT644/WT677
G231M/H	1.4	1.3	1.1	54	M8x1.25	2.2	WT644/WT643
G38	2.3	1.5	1.3	67	M10x1.25	2.2	WT338/WTA-6A
G45	2.74	1.69	1.22	74	8x1	3.3	HDA-48D
G62	3.8	1.9	1.4	73	10x1	4.75	HDA-48D
GT80	4.8	1.60	1.22	126	10x1.25	6	WJ-64

* w/spring starter

Exploded Illustration

G26/G231

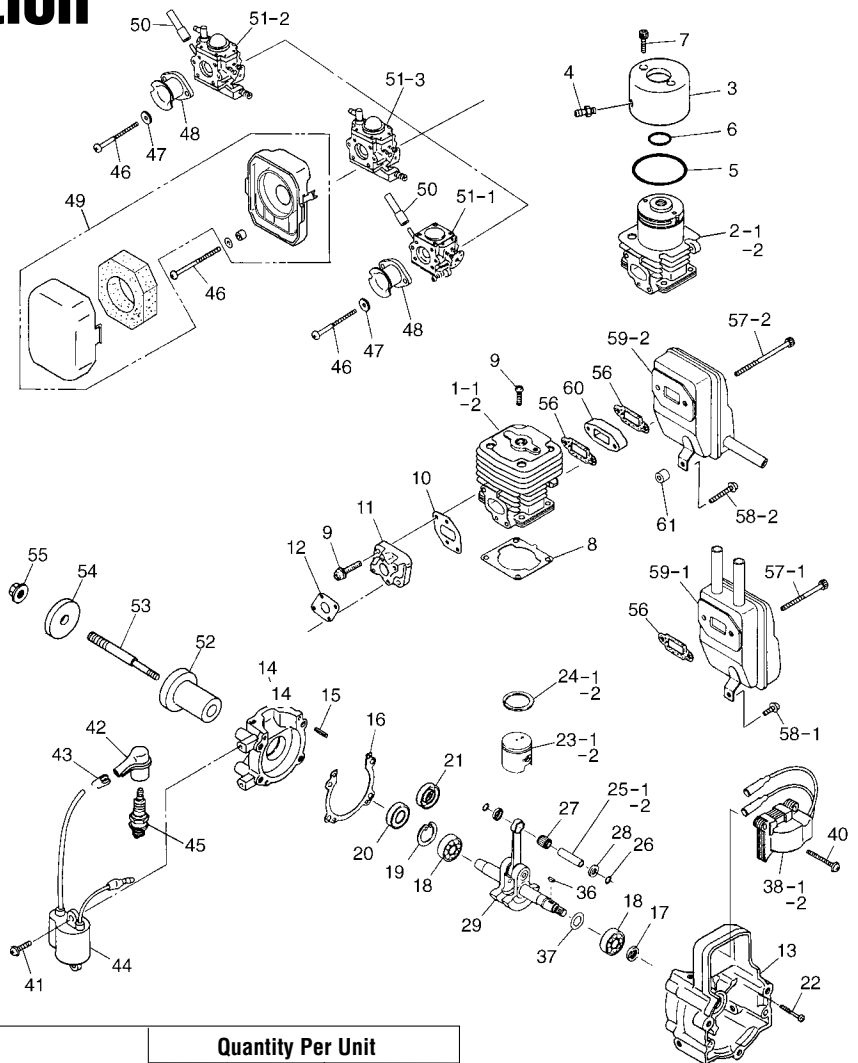

Key #	New Zen Part #	Out of Date Part #	Description	Quantity Per Unit				
				G260 PU	G260 PUM	G260 PUH	G231 PUM	G231 PUH
1-1	ZEN207512110	ZEN2601	CYLINDER	1	-	1	-	-
1-2	ZEN207012111	ZEN2301RCA	CYLINDER	-	-	-	-	1
2-1	ZEN207612110	ZEN2601M	CYLINDER	-	1	-	-	-
2-2	ZEN207812110	ZEN23102M	CYLINDER	-	-	-	1	-
3	ZEN207612210	ZEN2603M	JACKET	-	1	-	1	-
4	ZEN0785100515	ZEN2304M	JOINT	-	2	-	2	-
5	ZEN0700013040	ZEN23105M	O-RING 3 x 40	-	1	-	1	-
6	ZEN207612320	ZEN23106M	O-RING 1.5 x 15.5	-	1	-	1	-
7	ZEN116012330	ZEN2307M	BOLT M3 x 8	-	2	-	2	-
8	ZEN207513120	ZEN23108	GASKET, CYLINDER	1	1	1	1	1
9	ZEN331012281	ZEN2309	BOLT M5X20	6	6	6	6	6
10	ZEN207513150	ZEN2305RC	GASKET, INSULATOR	1	1	1	1	1
11	ZEN114813162	ZEN23111	INSULATOR	1	1	1	1	1
12	ZEN207514120	ZEN23112	GASKET, CARBURETOR	1	1	2	1	2
	ZEN207521100	ZEN23114	CRANKCASE, COMPLETE	1	1	1	1	1
13			CRANKCASE, REAR	1	1	1	1	1
14			CRANKCASE, FRONT	1	1	1	1	1
15	ZEN262921130	ZEN6213	PIN	3	3	3	3	3
16	ZEN207521140	ZEN23116	GASKET	1	1	1	1	1
17	ZEN216921210	ZEN3828	SEAL, 12 x 22 x 7	1	1	1	1	1
18	ZEN33301412	ZEN2318	BEARING	2	2	2	2	2
19	ZEN0406502812	ZEN2319	SNAP RING	1	1	1	1	1
20	ZEN0603406001	ZEN2320	BEARING	1	-	1	-	1
21	ZEN185021220	ZEN2321M	SEAL, 12 x 28 x 7	-	1	-	1	-

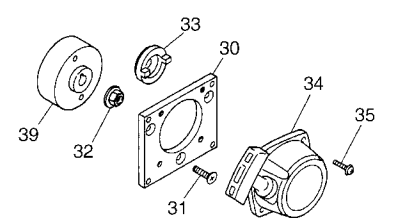

Exploded Illustration

G26/G231 continued

Key #	New Zen Part #	Out of Date Part #	Description	Quantity Per Unit				
				G260 PU	G260 PUM	G260 PUH	G231 PUM	G231 PUH
22	ZEN0125230530	ZEN2322	BOLT, M5 x 30	4	4	4	4	4
23-1	ZENT208841110	ZEN2623	PISTON	1	1	1	-	-
23-2	ZENT207041110	ZEN2320RC	PISTON	-	-	-	1	1
24-1	ZENT208841210	ZEN2624	RING	1	1	1	-	-
24-2	ZENT207041210	ZEN2321RC	RING	-	-	-	1	1
25-1	ZEN160041310	ZEN2625	PISTON PIN	1	1	1	-	-
25-2	ZEN110141310	ZEN2322RC	PISTON PIN	-	-	-	1	1
26	ZEN126041320	ZEN2323RC	SNAP RING	2	2	2	2	2
27	ZEN550041410	ZEN2324RC	BEARING	1	1	1	1	1
28	ZEN110141340	ZEN2325RC	WASHER	2	2	2	2	2
29	ZENT207542000	ZEN23129	CRANKSHAFT, COMPLETE	1	1	1	1	1
30	ZEN115574110	ZEN2330	MOUNT, PLATE	1	1	1	1	1
31	ZEN026210516	ZEN2331	SCREW, M5 x 16	3	3	3	3	3
32	ZEN165043230	ZEN2327RC	NUT, M8	1	-	-	-	-
33	ZEN116075210	ZEN2333M	PULLEY	-	1	1	1	1
34	ZEN186175101	ZEN2634	RECOIL ASSEMBLY	-	1	1	1	1
35	ZEN026330414	ZEN2341	SCREW, M4 x 14	-	4	4	4	4
36	ZEN100043240	ZEN2328RC	KEY	1	1	1	1	1
37	ZEN114043250	ZEN2337	SHIM	1	1	1	1	1
38-1	ZEN262971210	ZEN6236	COIL, (GREY)	1	-	-	-	-
38-2	ZEN116071211	ZEN2339M	COIL, (RED)	-	1	1	1	1
39	ZEN115571110	ZEN2354	ROTOR	1	1	1	1	1
40	ZEN026030422	ZEN6241	SCREW M4 x 22	2	2	2	2	2
41	ZEN026330414	ZEN2341	SCREW M4 x 14	2	2	2	2	2
42	ZENT207572210	ZEN2638	PLUG CAP	1	1	1	1	1
43	ZEN190072120	ZEN6239	SPRING	1	1	1	1	1
44	ZEN262971311	ZEN6237	COIL	1	1	1	1	1
45	ZENT207073110	ZEN26451	SPARK PLUG RZ7C	1	1	1	1	1
	ZEN369991975	ZEN2667M	SPARK PLUG MARINE ONLY	-	1	-	1	-
46	ZEN026330555	ZEN2648	SCREW, M5 x 55	2	2	2	2	2
47	ZEN114283110	ZEN2647	SPACER, 5 x 10 x 1.6	2	2	-	2	-
48	ZEN848ES08300	ZEN2649A	AIR TUNNEL (VENTURI)	1	1	-	1	-
49	ZENT207782000	ZEN23150H	CLEANER ASSEMBLY	-	-	1	-	1
50	ZEN2650	ZEN2650	TUBE	1	1	-	1	-
51-1	ZENT207581000	ZEN2651	CARBURETOR ASSY WT-645	1	-	-	-	-
51-2	ZENT207681000	ZEN23151	CARBURETOR ASSY WT-644	-	1	-	1	-
51-3	ZENT207781000	ZEN23152	CARBURETOR ASSY WT-643	-	-	1	-	1
52	ZEN115243260	ZEN2359	HUB	1	-	-	-	-
53	ZEN115243281	ZEN2360	STUD	1	-	-	-	-
54	ZEN115243290	ZEN2361	WASHER	1	-	-	-	-
55	ZEN335053410	ZEN2362	NUT, M8	1	-	-	-	-
56	ZEN114013141	ZEN23156	GASKET, MUFFLER	1	-	2	-	2
57-1	ZEN0125230550	ZEN2357	BOLT, M5 x 502	-	-	-	-	-
57-2	ZEN0125230560	ZEN2357H	BOLT, M5 x 60	-	-	2	-	2
58-1	ZEN026330408	ZEN2358	SCREW, M4 x 8	1	-	-	-	-
58-2	ZEN026390416	ZEN2358H	SCREW, M4 x 16	-	-	1	-	1
59-1	ZENT207515110	ZEN2655	MUFFLER	1	-	-	-	-
59-2	ZEN114808010	ZEN2355	MUFFLER	-	-	1	-	1
60	ZEN114515412	ZEN2366	SPACER	-	-	1	-	1
61	ZEN115815420	ZEN2367	SPACER	-	-	1	-	1
62	ZENT303991310	ZEN23124RC	SOCKET	1	1	1	1	1
	ZEN20010	ZEN20010	PISTON STOPPER, OPTION FOR G260PUA/M/H	1	1	1		
	ZEN20005	ZEN20005	PISTON STOPPER				1	1

Exploded Illustration

G38

(Standard Accessory for G380PU)

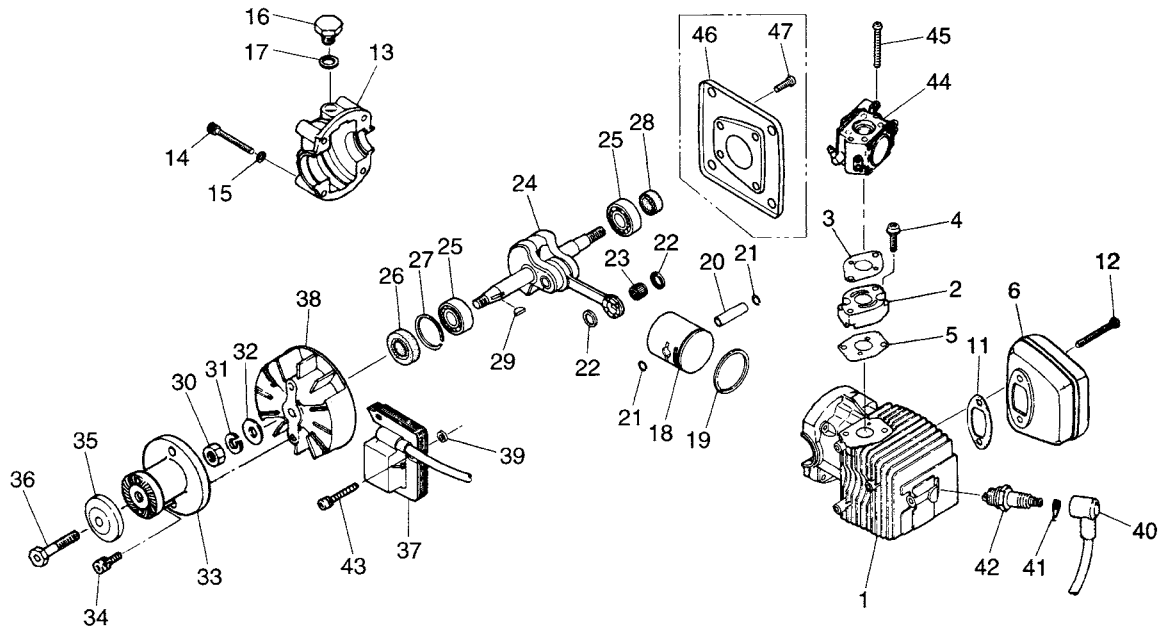

Index No.	New ZEN Part No.	Out of Date Part No.	Description	Qty/ unit
1	ZEN337812111	ZEN3801	CYLINDER	1
2	ZEN333014111	ZEN3802	INSULATOR	1
3	ZEN333014121	ZEN3803	CARB GASKET	1
4	ZEN026020520	ZEN3804	INSULATOR SCREW	2
5	ZEN333014132	ZEN3805	INSULATOR GASKET	1
6	ZEN337815000	ZEN3806	MUFFLER ASSEMBLY	1
11	ZEN284115210	ZEN3811	MUFFLER GASKET	1
12	ZEN333015220	ZEN3812	MUFFLER BOLT	2
13	ZEN337821110	ZEN3813	CRANKCASE	1
14	ZEN0125230540	ZEN3814	CASE BOLT	4
15	ZEN029220510	ZEN3815	CASE WASHER	4
16	ZEN312013510	ZEN3816	CASE PLUG	1
17	ZEN313013520	ZEN3817	PLUG GASKET	1
18	ZEN334041113	ZEN3818	PISTON	1
19	ZEN334041211	ZEN3819	PISTON RING	1
20	ZEN330441310	ZEN3820	PISTON PIN	1
21	ZEN331041320	ZEN3821	PIN RETAINER	2
22	ZEN165041510	ZEN3822	CONROD SPACER	2
23	ZEN331041410	ZEN3823	CONROD BEARING	1
24	ZEN337842000	ZEN3824	CRANKSHAFT	1
25	ZEN603006201	ZEN3825	CRANKSHAFT BEARING	2
26	ZEN165021220	ZEN3826	FRONT OIL SEAL	1
27	ZEN0406503212	ZEN3827	SNAP RING	1
28	ZEN216921210	ZEN3828	REAR OIL SEAL	1
29	ZEN126043240	ZEN3829	KEY	1
30	ZEN165043230	ZEN2327RC	ROTOR NUT	1
31	ZEN029020820	ZEN3831	LOCK WASHER	1
32	ZEN0164120812	ZEN3832	ROTOR WASHER	1
33	ZEN260951110	ZEN3833	PROP HUB (NEW)	1
34	ZEN354411510	ZEN6232	HUB BOLT	2
35	ZEN114543290	ZEN3835	PROP WASHER (NEW)	1

Index No.	New Part No.	Out of Date Part No.	Description	Qty/ unit
36	ZEN260951411	ZEN3836	PROP BOLT (NEW)	2
37	ZEN337871110	ZEN3837	MODULE	1
38	ZEN260971210	ZEN3838	ROTOR (NEW)	1
39	ZEN126071261	ZEN3839	SPACER (MODULE)	3
40	ZEN262972210	ZEN6238	PLUG CAP (BLACK)	1
41	ZEN190072120	ZEN6239	CAP SPRING	1
42	ZEN6242	ZEN6242	SPARK PLUG, C859	1
43	ZEN3843	ZEN3843	MODULE BOLT	3
44-1	ZEN3844	ZEN3844	CARB ASS'Y (HT-338) ^{W/CHOKE}	1
45	ZEN026010540	ZEN3845	CARB SCREW	2
46	ZEN337885111	ZEN3846	MOUNT	1
47	ZEN026000512	ZEN3847	MOUNTING BOLT	4
	ZEN337806040	ZEN3871	SCREW/NUT SET	1
	ZEN20005	ZEN20005	PISTON STOPPER } for G380PU	1

Exploded Illustration

G45

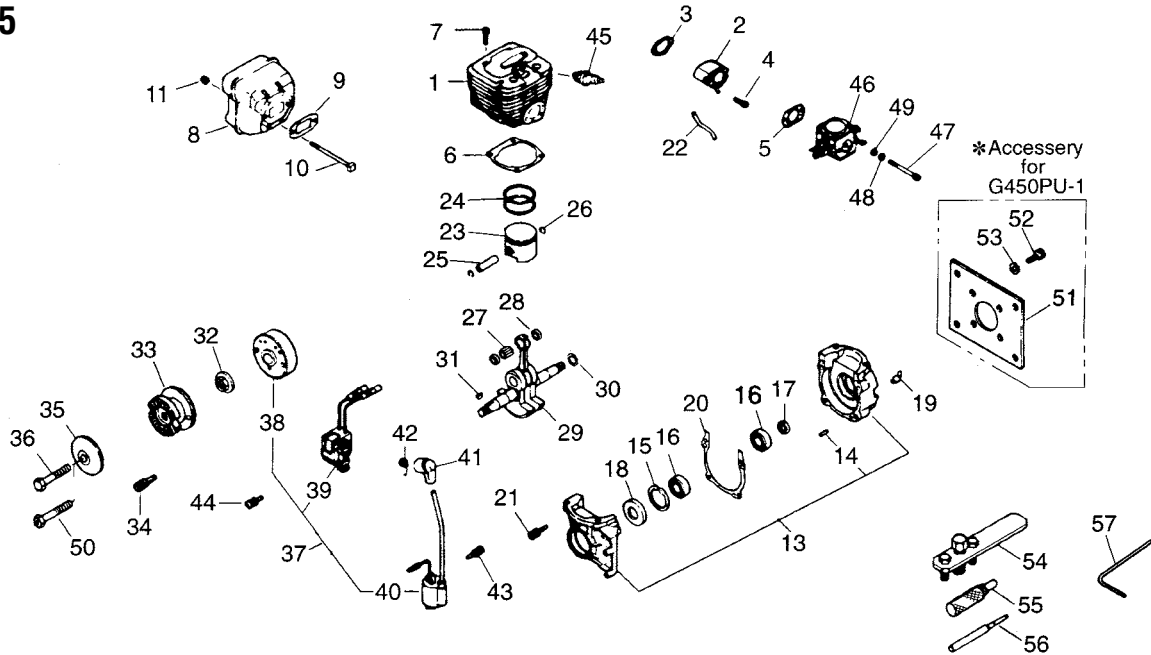

Index No.	New Part No.	Out of Date Part No.	Description	Qty/ unit
1	ZEN281712111	ZEN4501	CYLINDER	1
2	ZEN281714110	ZEN4502	INSULATOR	1
3	ZEN281714121	ZEN4503	INSULATOR GASKET	1
4	ZEN48013180	ZEN4504	BOLT	2
5	ZEN848C9014C2	ZEN6204	CARBURETOR GASKET	1
6	ZEN267014211	ZEN4506	CYLINDER GASKET	1
7	ZEN48013180	ZEN4504	BOLT	4
8	ZEN262951111	ZEN6207	MUFFLER	1
9	ZEN335615210	ZEN6208	MUFFLER GASKET	1
10	ZEN335615220	ZEN6209A	MUFFLER BOLT	2
11	ZEN285015230	ZEN6210	MUFFLER NUT	2
13	ZEN281721101	ZEN4513	CRANKCASE COMP.	1
14	ZEN262921130	ZEN6213	CASE PIN	3
15	ZEN0406503515	ZEN6214	SNAP RING	1
16	ZENT401221240	ZEN6215	BEARING	2
17	ZEN152021220	ZEN6216	REAR OIL SEAL	1
18	ZEN140021220	ZEN6217	FRONT OIL SEAL	1
19	ZEN267021250	ZEN6276	ELBOW FUEL NIPPLE	1
20	ZEN281721311	ZEN4520	CASE GASKET	1
21	ZEN48013180	ZEN4504	BOLT	4
22	ZEN281722210	ZEN4522	PIPE	1
23	ZEN267041114	ZEN4523	PISTON	1
24	ZEN267041211	ZEN4524	PISTON RING	2
25	ZEN335041310	ZEN4525	PISTON PIN	1
26	ZEN335041320	ZEN6223	PIN RETAINER	2
27	ZEN140041410	ZEN6224	CONROD BEARING	1
28	ZEN267041510	ZEN4528	WASHER	2
29	ZEN281742001	ZEN4529	CRANKSHAFT COMP.	1
30	ZEN130042410	ZEN6228	SHIM	0-2
31	ZEN100043240	ZEN6227	KEY	1
32	ZEN140043230	ZEN6229	FLYWHEEL NUT	1

Index No.	New Part No.	Out of Date Part No.	Description	Qty/ unit
33	ZEN262951110	ZEN6230	PROP HUB	1
34	ZEN354411510	ZEN6232	HUB BOLT	2
35	ZEN262951310	ZEN6233	WASHER	1
36	ZEN262951410	ZEN6234	PROP BOLT	1
37	ZEN6257	ZEN6257	MAGNETO ASSEMBLY	1
38	ZEN149071110	ZEN6235	ROTOR	1
39	ZEN262971210	ZEN6236	SOURCE COIL	1
40	ZEN262971311	ZEN6237	IGNITION COIL	1
41	ZEN262972210	ZEN6238	PLUG CAP (BLACK)	1
42	ZEN90072120	ZEN6239	CAP SPRING	1
43	ZEN026330416	ZEN4543	SOURCE COIL SCREW	2
44	ZEN26030422	ZEN6241	COIL SCREW	2
45	ZEN6242	ZEN6242	SPARK PLUG	1
46	ZEN6243	ZEN6243	CARBURETOR ASSEMBLY	1
47	ZEN0125230550	ZEN4547	BOLT	2
48	ZEN6245	ZEN6245	WASHER	2
49	ZEN0160120513	ZEN6246	WASHER	2
50	ZEN262991510	ZEN6247	BOLT	1
51	ZEN262891110	ZEN6248	MOUNT	1
52	ZEN0125230614	ZEN6249	BOLT	4
53	ZEN029020615	ZEN6250	WASHER	4
54	ZEN149096101	ZEN6251	PULLER ASSEMBLY	1
55	ZEN20005	ZEN20005	STOPPER (OPTIONAL)	1
56	ZEN6253	ZEN6253	GUIDE (OPTIONAL)	1
57	DISCONTINUED	ZEN4557	WRENCH (OPTIONAL)	1

Exploded Illustration

G62

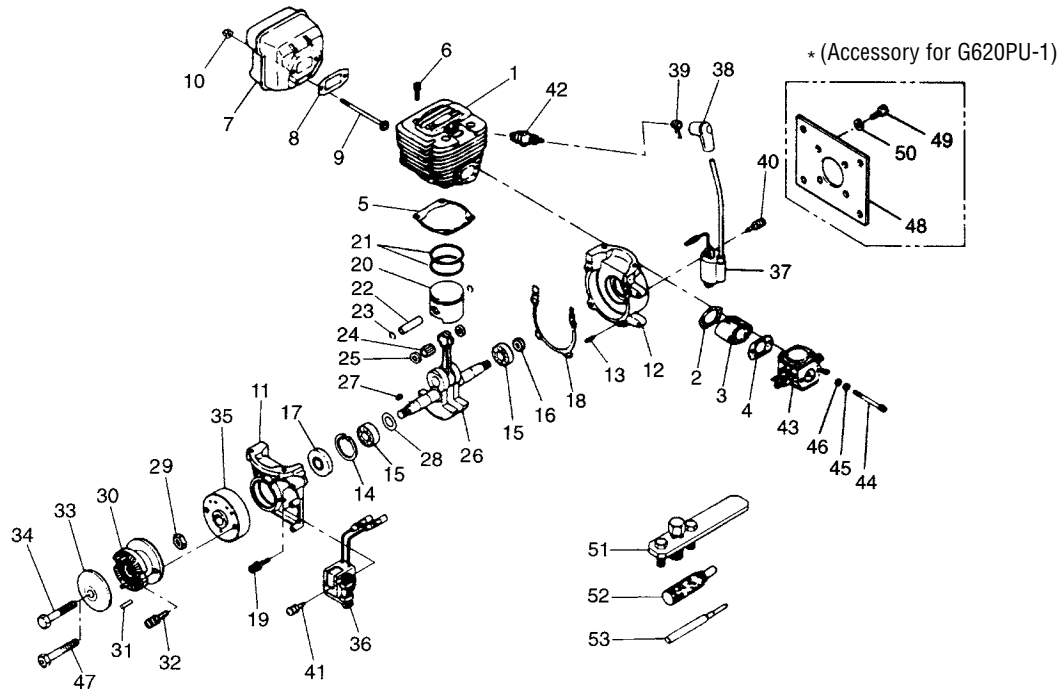

Index No.	New ZEN Part No.	Out of Date Part No.	Description	Qty/ unit
1	ZEN336612116	ZEN6201	CYLINDER	1
2	ZEN848C9014B3	ZEN6202	INSULATOR GASKET	1
3	ZEN261814120	ZEN6203	INSULATOR	1
4	ZEN848C9014C2	ZEN6204	CARBURETOR GASKET	1
5	ZEN261614211	ZEN6205	CYLINDER BASE GASKET	1
6	ZEN331012281	ZEN2309	CYLINDER BOLT	4
7	ZEN262951111	ZEN6207	MUFFLER	1
8	ZEN335615210	ZEN6208	MUFFLER GASKET	1
9	ZEN335615220	ZEN6209	MUFFLER BOLT	2
10	ZEN285015230	ZEN6210	MUFFLER NUT	2
11,12	ZEN262921100	ZEN6211	CRANKCASE COMP.	1
13	ZEN262921130	ZEN6213	CASE PIN	3
14	ZEN0406503515	ZEN6214	SNAP RING	1
15	ZENT401221240	ZEN6215	BEARING	2
16	ZEN152021220	ZEN6216	REAR OIL SEAL	1
17	ZEN140021220	ZEN6217	FRONT OIL SEAL	1
18	ZEN262921311	ZEN6218	CRANKCASE GASKET	1
19	ZEN335021320	ZEN6219	CASE ASSEMBLY BOLT	4
20	ZEN261841112	ZEN6220	PISTON	1
21	ZEN261841210	ZEN6221	PISTON RING	4
22	ZEN336641310	ZEN6222	PISTON PIN	1
23	ZEN335041320	ZEN6223	PIN RETAINER	1
24	ZEN140041410	ZEN6224	NEEDLE BEARING	2
25	ZEN261641510	ZEN6225	CONNECTING ROD SPACER	1
26	ZEN262942002	ZEN6226	CRANKSHAFT COMP.	2
27	ZEN100043240	ZEN6227	KEY	1
28	ZEN130042410	ZEN6228	SHIM	2
29	ZEN140043230	ZEN6229	FLYWHEEL NUT	1
30	ZEN262951110	ZEN6230	HUB, PROPELLER COMP.	0-2
			FOR G620PU-1	1

Index No.	New ZEN Part No.	Out of Date Part No.	Description	Qty/ unit
31	ZEN0402500312	ZEN6231	PIN FOR G620PU-1	1
32	ZEN354411510	ZEN6232	HUB BOLT	2
33	ZEN262951310	ZEN6233	PROP WASHER	1
34	ZEN262951410	ZEN6234	PROP BOLT	1
35	ZEN149071110	ZEN6235	ROTOR	1
36	ZEN262971210	ZEN6236	SOURCE COIL	1
37	ZEN262971311	ZEN6237	IGNITION COIL	1
38	ZEN262972210	ZEN6238	PLUG CAP (BLACK)	1
39	ZEN190072120	ZEN6239	PLUG CAP SPRING	1
40	ZEN026330416	ZEN6240	IGNITION COIL SCREW	2
41	ZEN026030422	ZEN6241	SOURCE COIL SCREW	2
42	ZEN6242	ZEN6242	SPARK PLUG, C859	1
43	ZEN6243	ZEN6243	CARBURETOR ASSEMBLY	1
44	ZEN262982210	ZEN6244	CARB MOUNT SCREW	2
45	ZEN6245	ZEN6245	CARB WASHER	2
46	ZEN016020513	ZEN6246	WASHER	2
47	ZEN262991510	ZEN6247	TAP PROP BOLT	1
48	ZEN262891110	ZEN6248	MOUNT	1
49	ZEN0125230614	ZEN6249	BOLT	4
50	ZEN029020615	ZEN6250	WASHER	4
51	ZEN149096101	ZEN6251	PULLER ASSEMBLY	1
52	ZEN20005	ZEN20005	STOPPER (OPTIONAL)	1
53	ZEN6253	ZEN6253	PISTON PIN GUIDE	1
	ZEN6200	ZEN6200	SPRING STARTER	1
	ZEN6258	ZEN6255	HIGH-SPEED NEEDLE	1
	ZEN262981420	ZEN6256	LOW-SPEED NEEDLE	1
	ZEN6257	ZEN6257	MAGNETO ASSEMBLY	1

Exploded Illustration

GT80

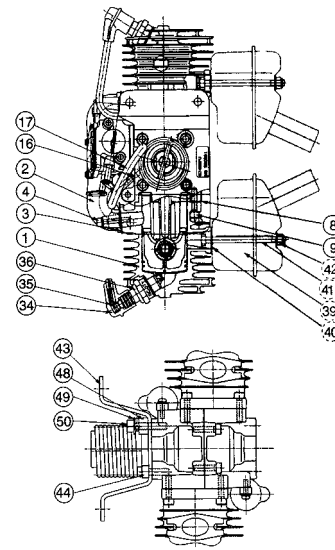
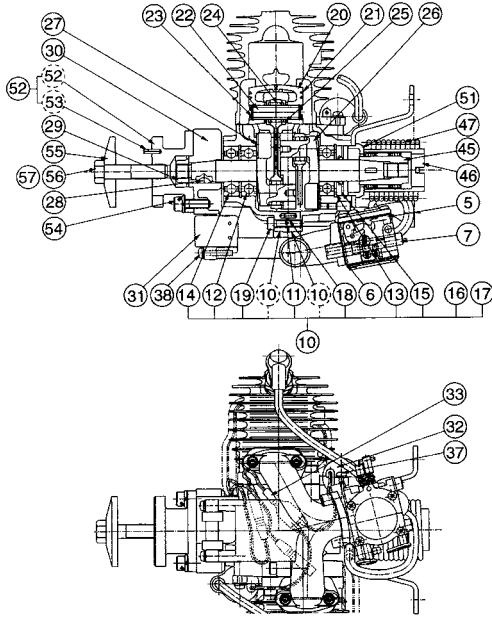

Index No.	New ZEN Part No.	Out of Date Part No.	Description	Qty/ unit
1	ZEN289812111	ZEN44501	CYLINDER	2
2	ZEN289814111	ZEN44502	MANIFOLD	1
3	ZEN285014123	ZEN44503	MANIFOLD GASKET	2
4	DISCONTINUED	ZEN3848	MANIFOLD BOLT	4
5	ZEN289881000	ZEN44505	CARBURETOR ASS'Y	1
6	ZEN289814131	ZEN44506	CARBURETOR GASKET	1
7	ZEN0125230550	ZEN2357	CARB BOLT	2
8	ZEN289814210	ZEN44508	CYLINDER GASKET	2
9	ZEN0215230520	ZEN44509	BOLT	8
10	ZEN289821001	ZEN44510	CRANKCASE ASS'Y	1
11	ZEN202921130	ZEN6213	PIN	4
12	ZENT401221240	ZEN6215	BEARING	2
13	ZEN0406503515	ZEN6214	SNAP RING	2
14	ZEN0603406202	ZEN44514	BEARING	1
15	ZEN140021220	ZEN6217	FRONT OIL SEAL	1
16	ZEN267021250	ZEN6276	FUEL NIPPLE ELBOW	1
17	ZEN106581100	ZEN44517	PIPE	1
18	ZEN289821310	ZEN44518	CRANKCASE GASKET	1
19	ZEN0215230520	ZEN44509	BOLT	4
20	ZEN285041110	ZEN44520	PISTON	2
21	ZEN285041210	ZEN44521	PISTON RING	4
22	ZEN285041310	ZEN44522	PISTON PIN	2
23	ZEN130041320	ZEN44523	PIN RETAINER	4
24	ZEN44524	ZEN44524	BEARING	2
25	ZEN44525	ZEN44525	THRUST WASHER	4
26	ZEN289842000	ZEN44526	CRANKSHAFT COMP	1
27	ZEN130042410	ZEN6228	SHIM	0-2
28	ZEN100043240	ZEN6227	KEY	1
29	ZEN140043230	ZEN6229	NUT	1
30	ZEN149071110	ZEN6235	ROTOR	1
31	ZEN262971210	ZEN6236	SOURCE COIL	1

Index No.	New ZEN Part No.	Out of Date Part No.	Description	Qty/ unit
32	ZEN262972210	ZEN6238	IGNITION COIL	2
33	ZEN289871510	ZEN44533	CORD	1
34	ZEN262922210	ZEN6238	PLUG CAP (BLACK)	2
35	ZEN190072120	ZEN6239	CAP SPRING	2
36	ZEN6242	ZEN6242	SPARK PLUG, C859	2
37	ZEN026330414	ZEN44537	SCREW	4
38	ZEN026030422	ZEN44538	SCREW	2
39	ZEN289815110	ZEN44539	MUFFLER	2
40	ZENT210015210	ZEN44540	MUFFLER GASLET	2
41	ZEN335615220	ZEN6209	MUFFLER BOLT	4
42	ZEN285015230	ZEN44542	NUT	4
43	ZEN289874110	ZEN44543	MOUNT	1
44	ZEN0125230614	ZEN44544	BOLT	3
45	ZEN269975110	ZEN44545	BOSS	1
46	ZEN269975200	ZEN44546	CLUTCH COMP	1
47	ZEN269975310	ZEN44547	SPRING	1
48	ZEN268975320	ZEN44548	COLLAR	1
49	ZEN331071150	ZEN44549	WASHER	1
50	ZEN0125230625	ZEN44550	BOLT	1
51	ZEN269975410	ZEN44551	PAD	1
52	ZEN262851101	ZEN44552	HUB. PROPELLER COMP	1
53	ZEN0402500312	ZEN44553	PIN	2
54	ZEN354411510	ZEN6232	HUB BOLT	2
55	ZEN262951310	ZEN6233	HUB WASHER	1
56	ZEN262951410	ZEN6234	PROP BOLT	1
57	ZEN262991510	ZEN6247	TAP PROP BOLT	1
58	ZEN111091320	ZEN44555	SOCKET	1
59	ZEN149096101	ZEN6251	PULLER ASS'Y (OPTIONAL)	1
60	ZEN20005	ZEN44554	STOPPER (OPTIONAL)	1
	ZEN289881410	ZEN44556	HIGH-SPEED NEEDLE	1
	ZEN289881420	ZEN44557	LOW-SPEED NEEDLE	1

G80A

Index No.	New ZEN Part No.	Out of Date Part No.	Description	Qty/ unit
01	ZEN286912110	ZEN8001	CYLINDER	2
02	ZENT208014110	ZEN8002	INTAKE MANIFOLD (BLACK)	1
20	ZENT200241110	ZEN8020	PISTON	2
21	ZEN266041211	ZEN8021	PISTON RING	2
40	ZEN20006	ZEN20006	CARBURETOR INSULATOR	1

Warranty Information

Warranty Repairs

Exclusive Warranty- Horizon Hobby, Inc., (Horizon) warrants that the Products purchased (the "Product") will be free from defects in materials and workmanship for a period of 3 years from the date of purchase by the Purchaser.

Limited Warranty

(a) This warranty is limited to the original Purchaser ("Purchaser") and is not transferable. REPAIR OR REPLACEMENT AS PROVIDED UNDER THIS WARRANTY IS THE EXCLUSIVE REMEDY OF THE PURCHASER. This warranty covers only those Products purchased from an authorized Horizon dealer. Third party transactions are not covered by this warranty. Proof of purchase is required for warranty claims. Further, Horizon reserves the right to change or modify this warranty without notice and disclaims all other warranties, express or implied.

(b) Limitations- HORIZON MAKES NO WARRANTY OR REPRESENTATION, EXPRESS OR IMPLIED, ABOUT NON-INFRINGEMENT, MERCHANTABILITY OR FITNESS FOR A PARTICULAR PURPOSE OF THE PRODUCT. THE PURCHASER ACKNOWLEDGES THAT THEY ALONE HAVE DETERMINED THAT THE PRODUCT WILL SUITABLY MEET THE REQUIREMENTS OF THE PURCHASER'S INTENDED USE.

(c) Purchaser Remedy- Horizon's sole obligation hereunder shall be that Horizon will, at its option, (i) repair or (ii) replace, any Product determined by Horizon to be defective. In the event of a defect, these are the Purchaser's exclusive remedies. Horizon reserves the right to inspect any and all equipment involved in a warranty claim. Repair or replacement decisions are at the sole discretion of Horizon. This warranty does not cover cosmetic damage or damage due to acts of God, accident, misuse, abuse, negligence, commercial use, or modification of or to any part of the Product. This warranty does not cover damage due to improper installation, operation, maintenance, or attempted repair by anyone other than Horizon. Return of any goods by Purchaser must be approved in writing by Horizon before shipment.

Damage Limits

HORIZON SHALL NOT BE LIABLE FOR SPECIAL, INDIRECT OR CONSEQUENTIAL DAMAGES, LOSS OF PROFITS OR PRODUCTION OR COMMERCIAL LOSS IN ANY WAY CONNECTED WITH THE PRODUCT, WHETHER SUCH CLAIM IS BASED IN CONTRACT, WARRANTY, NEGLIGENCE, OR STRICT LIABILITY. Further, in no event shall the liability of Horizon exceed the individual price of the Product on which liability is asserted. As Horizon has no control over use, setup, final assembly, modification or misuse, no liability shall be assumed nor accepted for any resulting damage or injury. By the act of use, setup or assembly, the user accepts all resulting liability.

If you as the Purchaser or user are not prepared to accept the liability associated with the use of this Product, you are advised to return this Product immediately in new and unused condition to the place of purchase.

Law: These Terms are governed by Illinois law (without regard to conflict of law principals).

Safety Precautions

This is a sophisticated hobby Product and not a toy. It must be operated with caution and common sense and requires some basic mechanical ability. Failure to operate this Product in a safe and responsible manner could result in injury or damage to the Product or other property. This Product is not intended for use by children without direct adult supervision. The Product manual contains instructions for safety, operation and maintenance. It is essential to read and follow all the instructions and warnings in the manual, prior to assembly, setup or use, in order to operate correctly and avoid damage or injury.

Questions, Assistance, and Repairs

Your local hobby store and/or place of purchase cannot provide warranty support or repair. Once assembly, setup or use of the Product has been started,

you must contact Horizon directly. This will enable Horizon to better answer your questions and service you in the event that you may need any assistance. For questions or assistance, please direct your email to productsupport@horizonhobby.com, or call 877.504.0233 toll free to speak to a service technician.

Inspection or Repairs

If this Product needs to be inspected or repaired, please call for a Return Merchandise Authorization (RMA). Pack the Product securely using a shipping carton. Please note that original boxes may be included, but are not designed to withstand the rigors of shipping without additional protection. Ship via a carrier that provides tracking and insurance for lost or damaged parcels, as Horizon is not responsible for merchandise until it arrives and is accepted at our facility. A Service Repair Request is available at www.horizonhobby.com on the "Support" tab. If you do not have internet access, please include a letter with your complete name, street address, email address and phone number where you can be reached during business days, your RMA number, a list of the included items, method of payment for any non-warranty expenses and a brief summary of the problem. Your original sales receipt must also be included for warranty consideration. Be sure your name, address, and RMA number are clearly written on the outside of the shipping carton.

Warranty Inspection and Repairs

To receive warranty service, you must include your original sales receipt verifying the proof-of-purchase date. Provided warranty conditions have been met, your Product will be repaired or replaced free of charge. Repair or replacement decisions are at the sole discretion of Horizon Hobby.

Non-Warranty Repairs

Should your repair not be covered by warranty the repair will be completed and payment will be required without notification or estimate of the expense unless the expense exceeds 50% of the retail purchase cost. By submitting the item for repair you are agreeing to payment of the repair without notification. Repair estimates are available upon request. You must include this request with your repair. Non-warranty repair estimates will be billed a minimum of ½ hour of labor. In addition you will be billed for return freight. Please advise us of your preferred method of payment. Horizon accepts money orders and cashiers checks, as well as Visa, MasterCard, American Express, and Discover cards. If you choose to pay by credit card, please include your credit card number and expiration date. Any repair left unpaid or unclaimed after 90 days will be considered abandoned and will be disposed of accordingly. Please note: non-warranty repair is only available on electronics and model engines.

Electronics and engines requiring inspection or repair should be shipped to the following address:

Horizon Service Center
4105 Fieldstone Road
Champaign, Illinois 61822

All other Products requiring warranty inspection or repair should be shipped to the following address:

Horizon Product Support
4105 Fieldstone Road
Champaign, Illinois 61822

Please call 877-504-0233 with any questions or concerns regarding this product or warranty.

Warranty Information (continued)

Registration Form

Fill in and mail this form along with your dated sales receipt (send a copy, keep the original for your files) within 10 days of purchase to:

Horizon Service Center
Attn: Zenoah Warranty Dept.
4105 Fieldstone Road
Champaign, IL 61822

Engine Type: _____

Date of Purchase: _____

Owner's Name: _____

Street Address: _____

City/State/Zip: _____

Daytime Phone Number: _____

Purchased From: _____

Dealer's Name: _____

Street Address: _____

City/State/Zip: _____

Please cut on dotted line.

